

THIS DRAWING IS UNPUBLISHED. RELEASED FOR PUBLICATION
 © COPYRIGHT - By - ALL RIGHTS RESERVED.

LOC	DIST	REVISIONS					
AF	50	P	LTR	DESCRIPTION	DATE	DWN	APVD
		G1		REV PER ECO 12-020692	27NOV12	JR	PD

- 1 CONTINUOUS STRIP ON REELS
- 2 FEED IS 8.89±0.076 [.350±.003].
- ③ 0.00381 [.000150] MIN TIN OVER
0.00127 [.000050] MIN NICKEL.
- ④ REELED WITH INTERLEAVING PAPER
- ⑤ PRELIMINARY - NOT FOR PRODUCTION

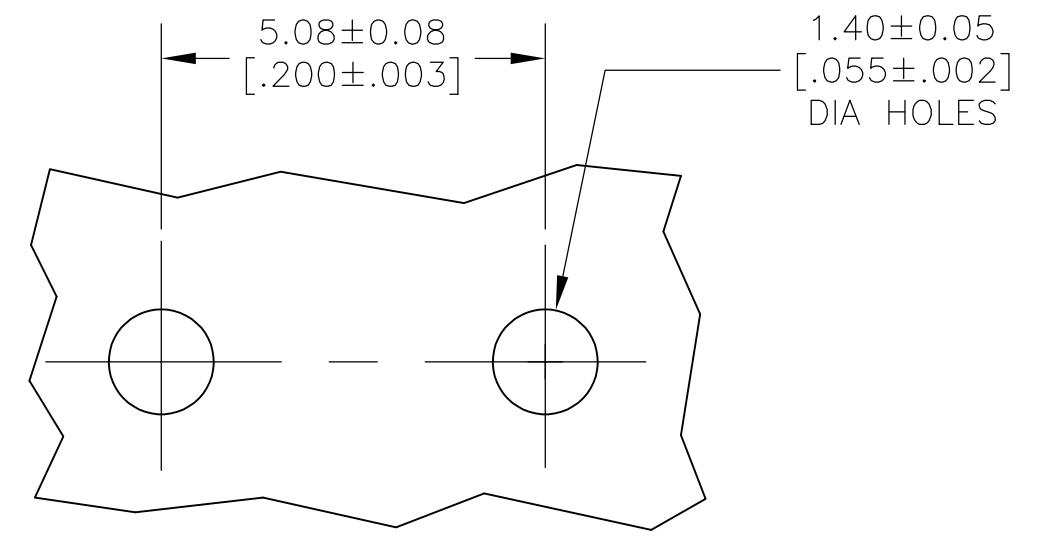
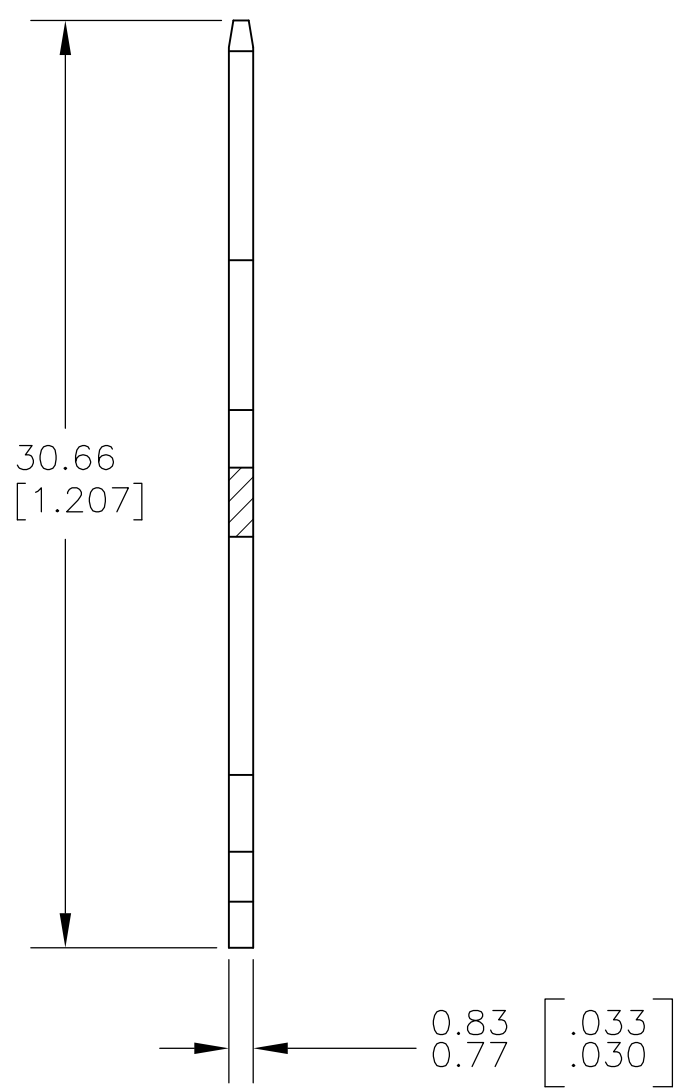
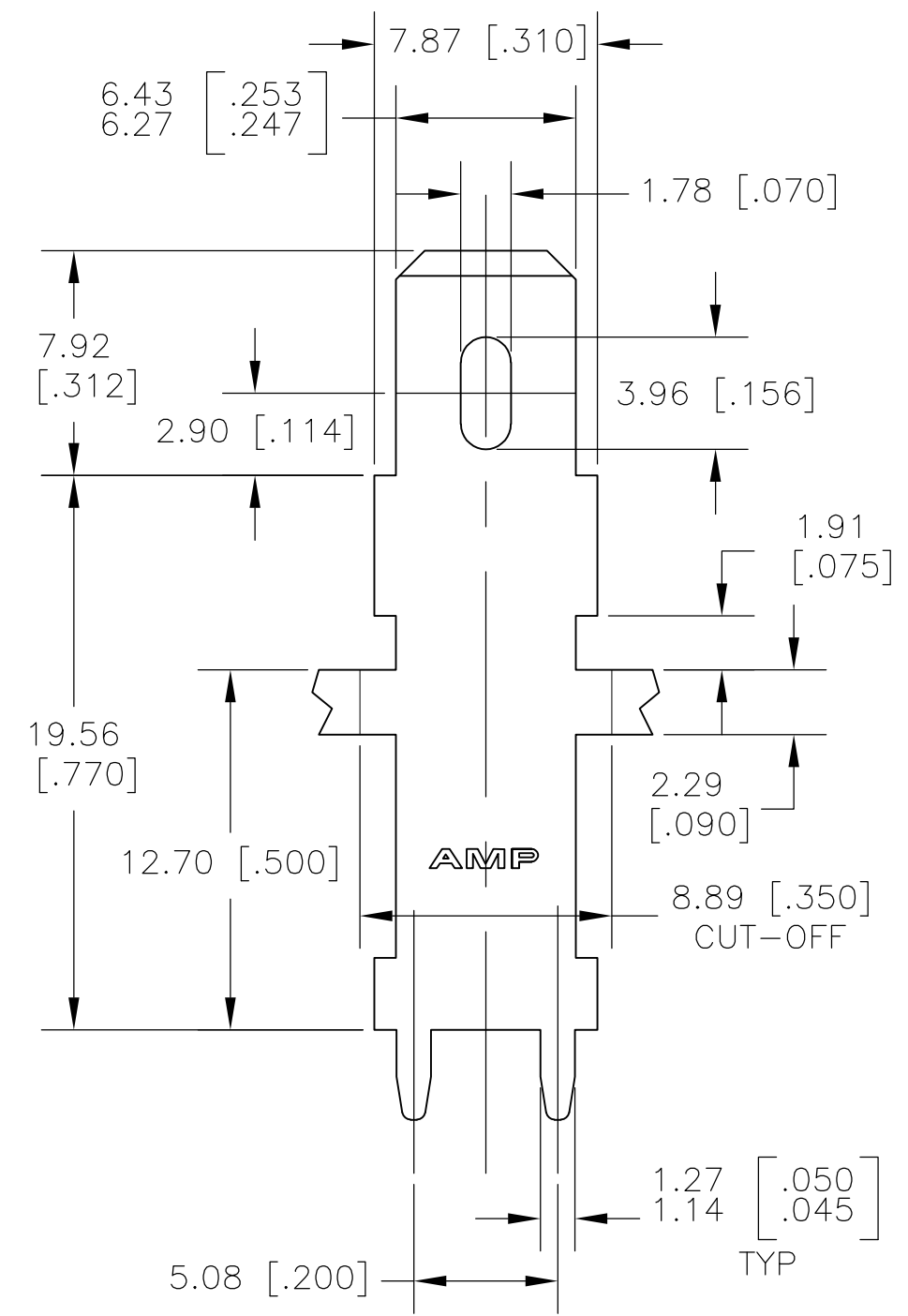

P.C. BOARD HOLES
SCALE 10:1

④	082 BRASS	⑤	63950-3
	H04 BRASS	⑤	63950-2
	082 BRASS		63950-1
	MATERIAL		PART NO.

THIS DRAWING IS A CONTROLLED DOCUMENT.		DWN	JR RUTH	05DEC00	STE TE Connectivity					
DIMENSIONS: MM [INCHES]		CHK	MS FEHER	05DEC00						
TOLERANCES UNLESS OTHERWISE SPECIFIED:		APVD	G PORTA	05DEC00	NAME					
0 PLC ± - 1 PLC ± - 2 PLC ± 0.25 [.010] 3 PLC ± - 4 PLC ± - ANGLES ± -		PRODUCT SPEC		TAB, FASTON, P.C. BOARD, 6.35 [.250] SERIES						
MATERIAL SEE TABLE		APPLICATION SPEC		114-2115		SIZE	CAGE CODE	DRAWING NO	RESTRICTED TO	
FINISH ③		WEIGHT		-		A3	00779	C-63950	-	
CUSTOMER DRAWING					SCALE	4:1	SHEET	1 OF 1	REV	G1