

## General Description

The MAX14986 evaluation kit (EV kit) provides a proven design to evaluate the MAX14986 dual-channel buffer. The EV kit contains four sections: an application circuit, characterization circuit, and two calibration traces.

The application circuit (Figure 1a) is designed to demonstrate the IC's use in redriving Serial-Attached SCSI (SAS) and Serial ATA (SATA) signals. This section of the EV kit operates from an external +5V supply that is regulated by an on-board LDO to +3.3V, which powers the MAX14986 (U1) device. All traces in the application circuit are 100Ω differential controlled-impedance traces.

The characterization circuit (Figure 1b) is provided for eye diagram evaluation using SMA connectors and 50Ω single-ended controlled-impedance traces. This section is powered by an external +3.3V supply.

## Features

- Application Circuit with SAS and SATA Input/Output
- Eye Diagram Test Circuit with SMA Inputs/Outputs
- Calibration Traces (50Ω Single-Ended Load Trace and 50Ω Single-Ended Through Trace)
- Lead(Pb)-Free and RoHS Compliant
- Proven PCB Layout
- Fully Assembled and Tested

## Quick Start (Application Circuit)

### Recommended Equipment

- MAX14986 EV kit
- +5V power supply
- Two SAS/SATA cables
- SAS/SATA device (e.g., a hard drive)
- SAS/SATA host (e.g., a PC)

### Procedure

The EV kit is fully assembled and tested. Follow the steps below to verify board operation:

- 1) Verify that all jumpers are in their default position, as shown in Table 1.
- 2) If testing in a SATA environment, change the shunt on jumper JU6 to the 1-2 position.
- 3) Connect the first SAS/SATA cable from the PC to the host connector (J1) on the EV kit.
- 4) Connect the second SAS/SATA cable from the device connector (J2) to the SAS/SATA device.
- 5) Verify communication between the host PC and SAS/SATA device.

*[Ordering Information](#) appears at end of data sheet.*

### Detailed Description of Hardware

The MAX14986 evaluation kit (EV kit) evaluates the MAX14986 dual-channel buffer. The device is designed to redrive Serial-Attached SCSI (SAS) or Serial ATA (SATA) signals. The EV kit is divided into four sections: application circuit, characterization circuit, and two calibration traces.

The application circuit utilizes 100Ω differential controlled impedance traces and provides two SAS connectors (J1 and J2), allowing for evaluation of the device in a SAS environment. The characterization circuit utilizes 50Ω single-ended, controlled-impedance traces and SMA input/output connectors, allowing for eye diagrams, and input/output return-loss measurements.

The lower-half of the EV kit provides two sets of calibration traces (Figure 1c), all of which are matched to the trace lengths in the characterization circuit. These traces provide a reference for determining the performance of only the device when evaluated in the characterization circuit.

**Table 1. Default Shunt Positions (JU1–JU11)**

JUMPER	SHUNT POSITION
JU1–JU4, JU7, JU8, JU10	2-3
JU5, JU9	1-2
JU6	2-3 (SAS)
JU11	Installed

**Table 2. Jumper JU11 Function**

SHUNT POSITION	VCC PIN (U1)	DESCRIPTION
Installed*	Connected to on-board LDO output	U1 powered by LDO output (+3.3V)
Not installed	Connected to external supply	Powered by +3.3V from an external supply or SAS power connector

\*Default position.

**Table 3. Jumper JU6 Function**

SHUNT POSITION	MODE PIN (U1)	DESCRIPTION
1-2	Connected to +3.3V	Signal type: SATA
2-3*	Connected to GND	Signal type: SAS
Not installed	Not connected	

\*Default position.

### Application Circuit (U1)

The application circuit provides the means for evaluating the device in a SAS/SATA application. This section of the EV kit provides two SAS/SATA connectors (J1 and J2), one for connection to a SAS/SATA host (e.g., a PC) and the other for connection to a SAS/SATA device (e.g., a hard drive).

### Power Supply (VIN)

The application circuit must be powered by +3.3V. There are two ways to get this voltage, either the on-board LDO (U3) or an external +3.3V power supply. When using the on-board voltage regulator, the LDO can be powered by the 4-pin Molex connector (H1) or by a +5V external supply connected to the VIN and GND PCB pads. When using the on-board LDO to supply power, there is a power LED (D1) to indicate the presence of +3.3V at VCC.

The user can also connect directly to a +3.3V supply, which is available on a SAS power connector. The shunt should be removed from jumper JU11 and a wire connected from the SAS power pin to pin-2 (right-most pin) of jumper JU11 (see Table 2).

### Mode Control (JU6)

The device can also be used to redrive Serial ATA (SATA) signals. The MODE pin configures the device to operate with SATA or SAS signals. See Table 3 for jumper JU6 functions.

**Device Enable (JU5)**

The U1 device is enabled/disabled by configuring jumper JU5 (see Table 4). When disabled, the device buffers are disabled and the part is placed in a low-power standby mode.

**Input Equalization (JU1, JU3)**

The IC host and device can be evaluated with or without input equalization. Configure JU1 to enable/disable the

host input (IN0P, IN0M) equalization and JU3 to enable/disable the device input (IN1P, IN1M) equalization (see Tables 5 and 6).

**Output Preemphasis (JU2, JU4)**

The IC host and device can be evaluated with or without output preemphasis. Configure JU2 to enable/disable the host output preemphasis and JU4 to enable/disable the device output preemphasis (see Tables 7 and 8).

**Table 4. Jumper JU5 Function**

SHUNT POSITION	EN PIN (U1)	DESCRIPTION
1-2*	Connected to +3.3V	Buffers enabled for normal operation
2-3	Connected to GND	Buffers disabled and device is in low-power standby mode
Not installed	Not connected	

\*Default position.

**Table 5. Jumper JU1 Function**

SHUNT POSITION	EQ0 PIN (U1)	DESCRIPTION
1-2	Connected to +3.3V	Host equalization enabled
2-3*	Connected to GND	Host equalization disabled
Not installed	Not connected	

\*Default position.

**Table 6. Jumper JU3 Function**

SHUNT POSITION	EQ1 PIN (U1)	DESCRIPTION
1-2	Connected to +3.3V	Device equalization enabled
2-3*	Connected to GND	Device equalization disabled
Not installed	Not connected	

\*Default position.

**Table 7. Jumper JU2 Function**

SHUNT POSITION	PE0 PIN (U1)	DESCRIPTION
1-2	Connected to +3.3V	Host preemphasis enabled
2-3*	Connected to GND	Host preemphasis disabled
Not installed	Not connected	

\*Default position.

**Table 8. Jumper JU4 Function**

SHUNT POSITION	PE1 PIN (U1)	DESCRIPTION
1-2	Connected to +3.3V	Device preemphasis enabled
2-3*	Connected to GND	Device preemphasis disabled
Not installed	Not connected	

\*Default position.

**Characterization Circuit (U2)**

The characterization circuit is provided as a separate test circuit for eye diagram evaluation of the IC. This circuit provides differential SMA inputs and outputs with 50Ω single-ended, controlled-impedance traces. Channel 1 is not utilized in this section of the EV kit, but provides the same performance as Channel 0.

**Power Supply (VCC)**

The characterization circuit is powered by an external +3.3V power supply connected between the VCC and GND pads.

**Mode Control (JU10)**

The U2 device can also be used to redrive Serial ATA (SATA) signals. The MODE pin configures the device to operate with SATA or SAS signals (see Table 9 for jumper JU10 functions).

**Device Enable (JU9)**

The U2 device is enabled/disabled by configuring jumper JU9 (see Table 10). When disabled, the device buffers are

disabled and the part is placed in a low-power standby mode.

**Input Equalization (JU7)**

The IC’s channel 0 can be evaluated with or without input equalization. Configure JU7 to enable/disable channel 0 equalization.

**Output Preemphasis (JU8)**

The IC’s channel 0 can be evaluated with or without preemphasis. Configure JU8 to enable/disable channel 0 preemphasis.

**Calibration Traces**

The bottom-half of the EV kit provides two sets of calibration traces, which can be used for further analysis. The lengths of the calibration traces are matched to the traces going from the SMA connector to the U2 device of the characterization circuit. The first calibration trace includes a 50Ω single-ended load termination and the second calibration trace is a through trace.

**Table 9. Jumper JU10 Function**

SHUNT POSITION	MODE PIN (U2)	DESCRIPTION
1-2	Connected to VCC (+3.3V)	Signal type: SATA
2-3*	Connected to GND	Signal type: SAS
Not installed	Not connected	

\*Default position.

**Table 10. Jumper JU9 Function**

SHUNT POSITION	EN PIN (U2)	DESCRIPTION
1-2*	Connected to VCC (+3.3V)	Buffers enabled for normal operation
2-3	Connected to GND	Buffers disabled and device is in low-power standby mode
Not installed	Not connected	

\*Default position.

**Table 11. Jumper JU7 Function**

SHUNT POSITION	EQ0 PIN (U2)	DESCRIPTION
1-2	Connected to VCC (+3.3V)	Channel 0 equalization enabled
2-3*	Connected to GND	Channel 0 equalization disabled
Not installed	Not connected	

\*Default position.

**Table 12. Jumper JU8 Function**

SHUNT POSITION	PE0 PIN (U2)	DESCRIPTION
1-2	Connected to VCC (+3.3V)	Channel 0 preemphasis enabled
2-3*	Connected to GND	Channel 0 preemphasis disabled
Not installed	Not connected	

\*Default position.

## Component List

DESIGNATION	QTY	DESCRIPTION
C1–C12, C19–C26, C32–C35	24	0.01 $\mu$ F $\pm$ 10%, 25V X7R ceramic capacitors (0402) Murata GRM155R71E103KA TDK C1005X7R1E103K
C13–C16, C27–C30	8	2.2 $\mu$ F $\pm$ 10%, 10V X7R ceramic capacitors (0603) Murata GRM188R71A225K
C17, C31	2	1 $\mu$ F $\pm$ 10%, 16V X7R ceramic capacitors (0603) Murata GRM188R71C105K TDK C1608X7R1C105K
C18	1	0.1 $\mu$ F $\pm$ 10%, 16V X7R ceramic capacitor (0402) Murata GRM155R71C104K TDK C1005X7R1C104K
D1	1	Green LED (0603)
H1	1	Disk-drive power connector

DESIGNATION	QTY	DESCRIPTION
J1, J2	2	7-position SAS vertical connectors
JU1–JU10	10	3-pin headers, 0.1in centers
JU11	1	2-pin header, 0.1in centers
P1–P10	10	Edge-mount receptacle SMA connectors
R1	1	200 $\Omega$ $\pm$ 5% resistor (0603)
R2, R3	2	49.9 $\Omega$ $\pm$ 1% resistors (0603)
U1, U2	2	1.5/3.0/6.0GT/s SAS/SATA redrivers (28 TQFN-EP*) Maxim MAX14986ETI+
U3	1	3.3V regulator (6 SOT23) Maxim MAX6329TPUT-T+ (Top Mark: AAIP)
—	11	Shunts
—	1	PCB: MAX14986 EVALUATION KIT

\*EP = Exposed pad.

## Component Suppliers

SUPPLIER	PHONE	WEBSITE
Murata Americas	770-436-1300	<a href="http://www.murataamericas.com">www.murataamericas.com</a>
TDK Corp.	847-803-6100	<a href="http://www.component.tdk.com">www.component.tdk.com</a>

**Note:** Indicate that you are using the MAX14986 when contacting these component suppliers.

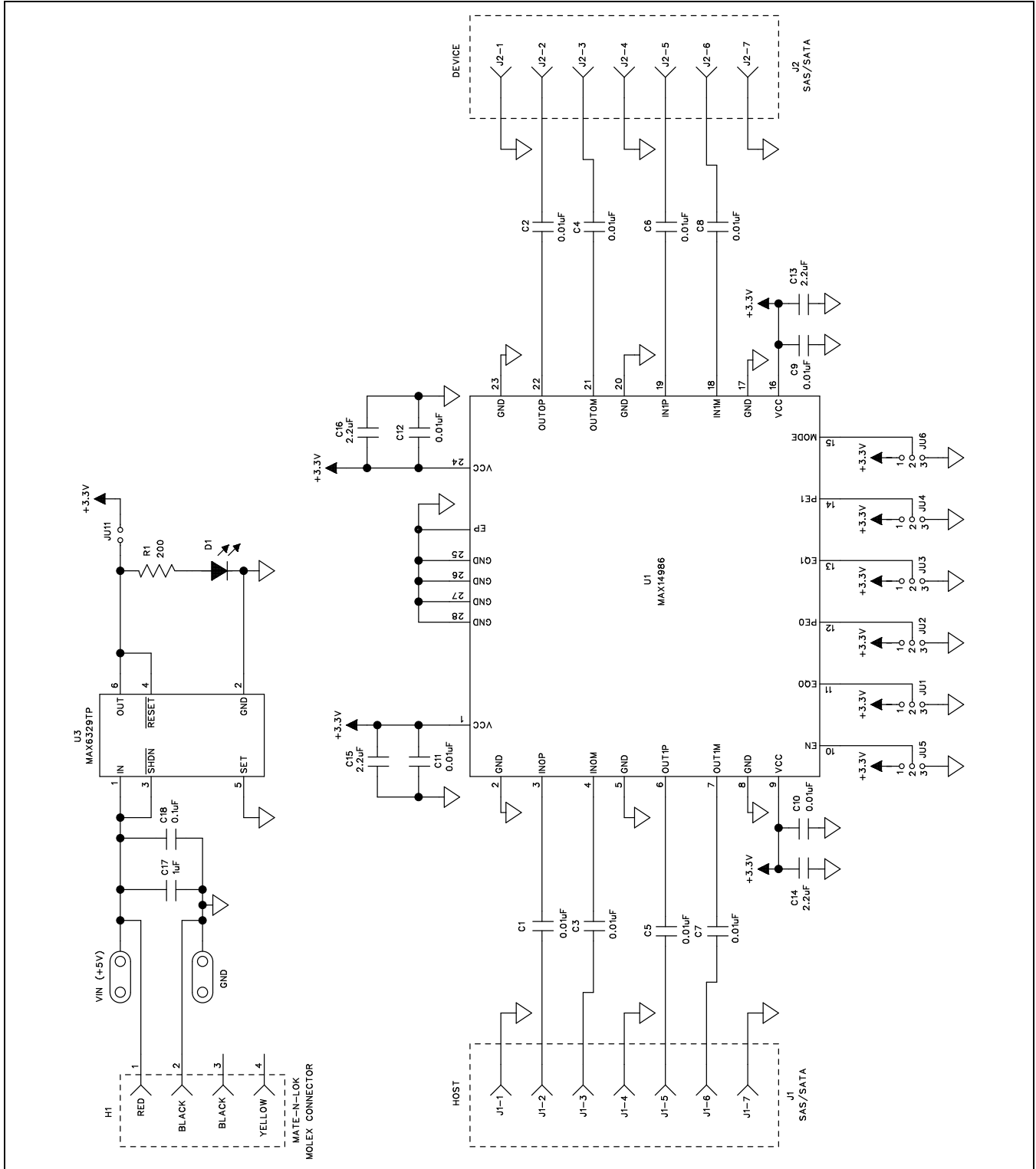

Figure 1a. MAX14986 EV Kit Schematic—Application Circuit (Sheet 1 of 3)

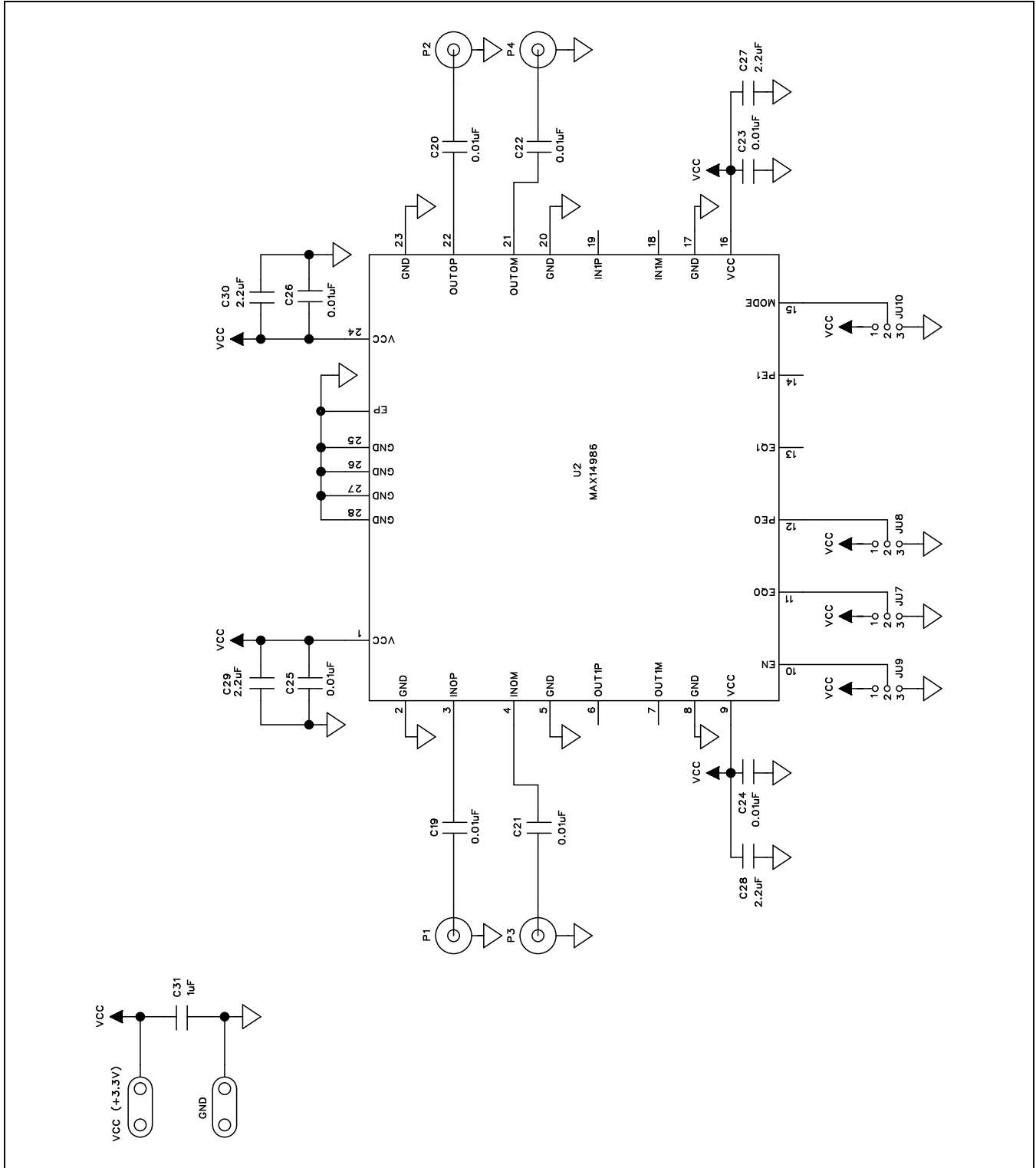

Figure 1b. MAX14986 EV Kit Schematic—Characterization Circuit (Sheet 2 of 3)

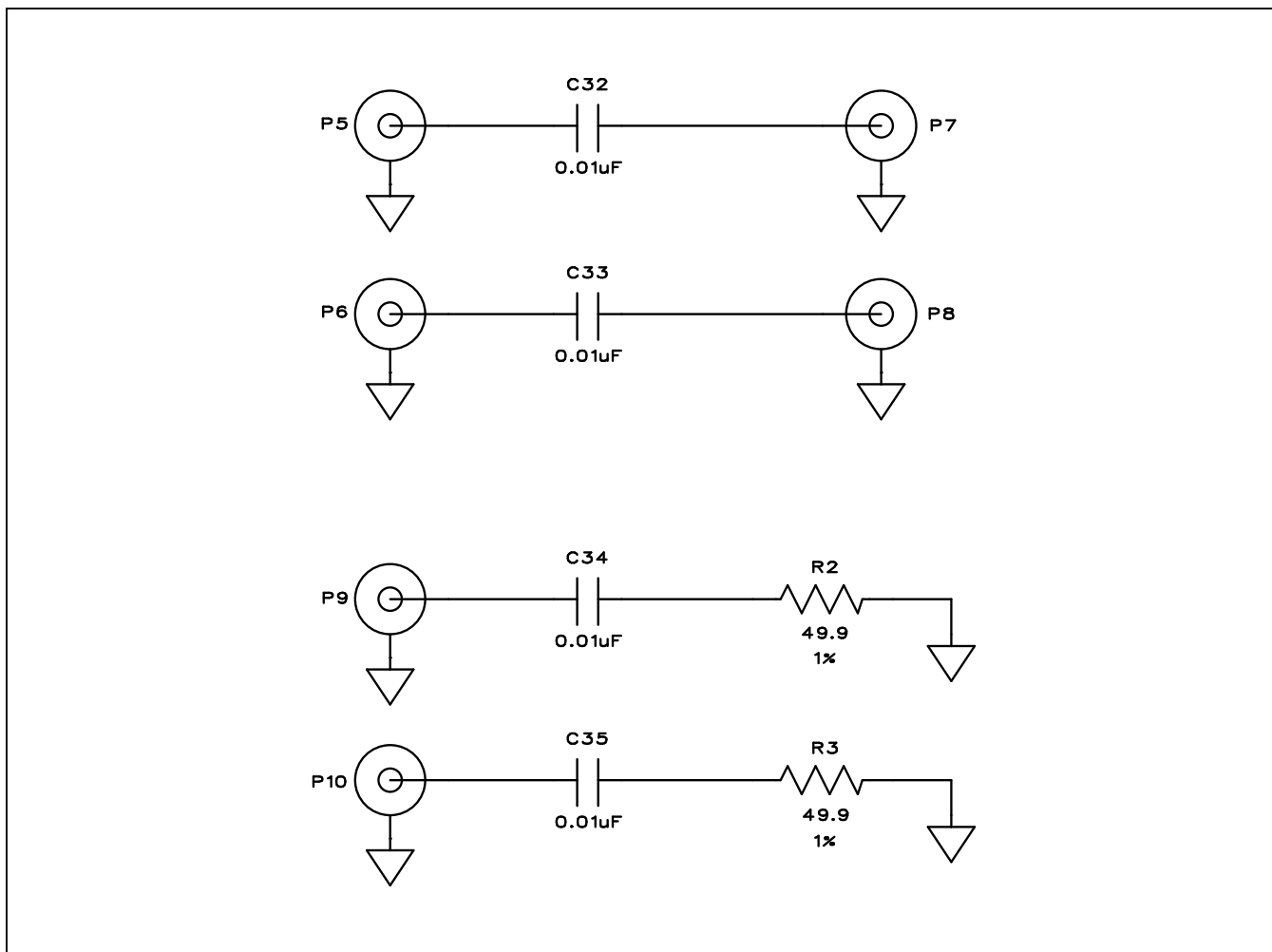

Figure 1c. MAX14986 EV Kit Schematic—Calibration Traces (Sheet 3 of 3)



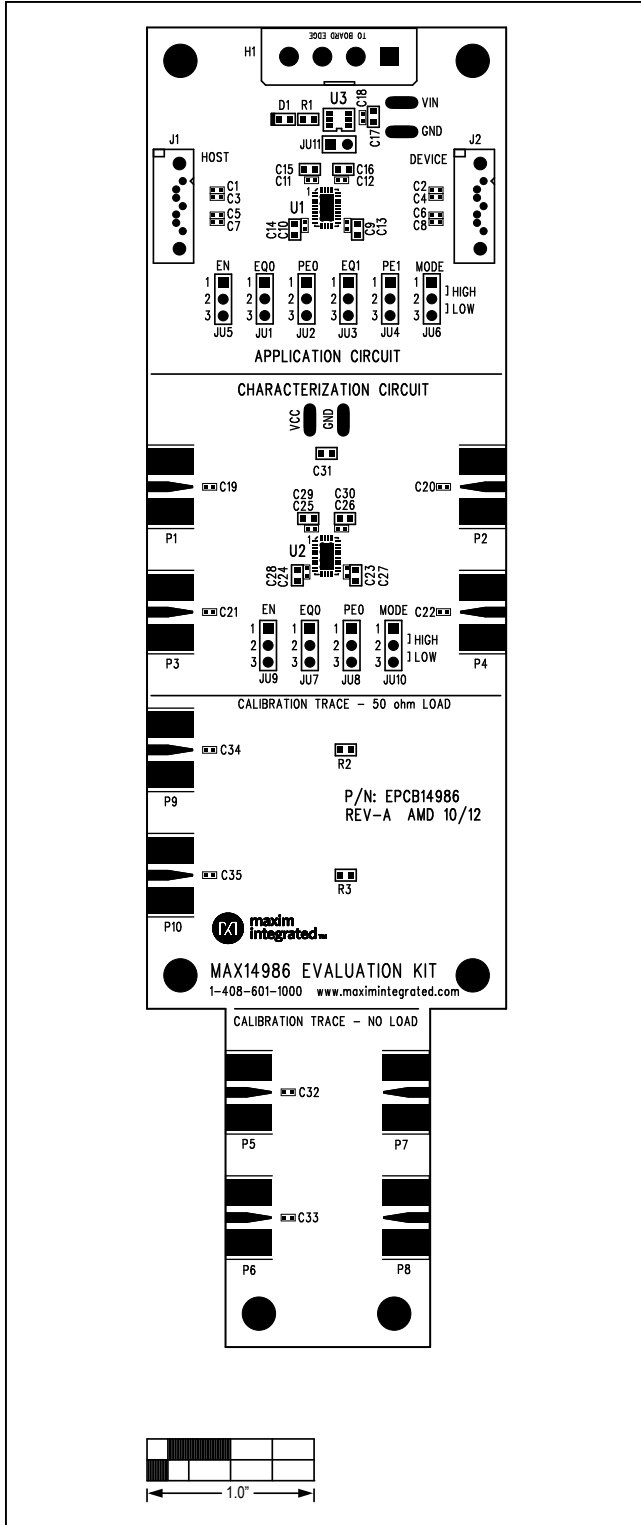

Figure 2. MAX14986 EV Kit Component Placement Guide—Component Side

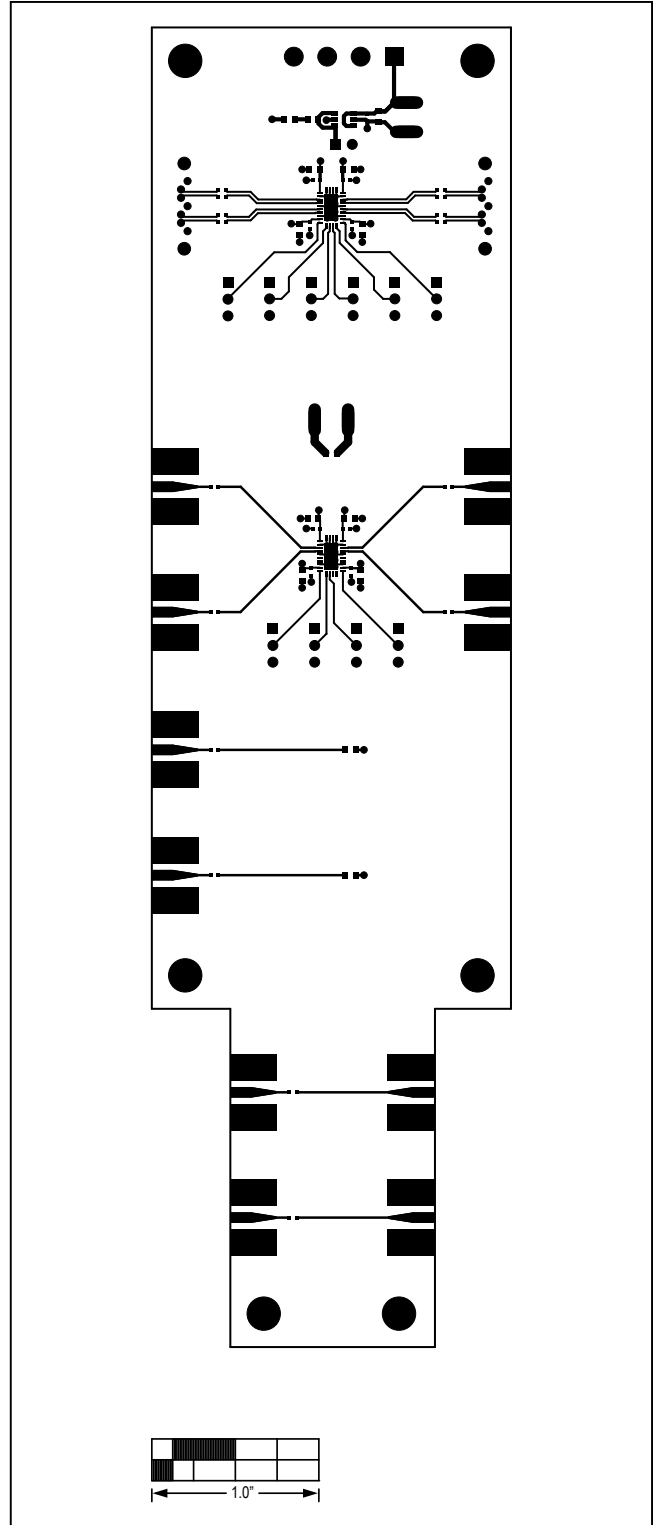

Figure 3. MAX14986 EV Kit PCB Layout—Component Side

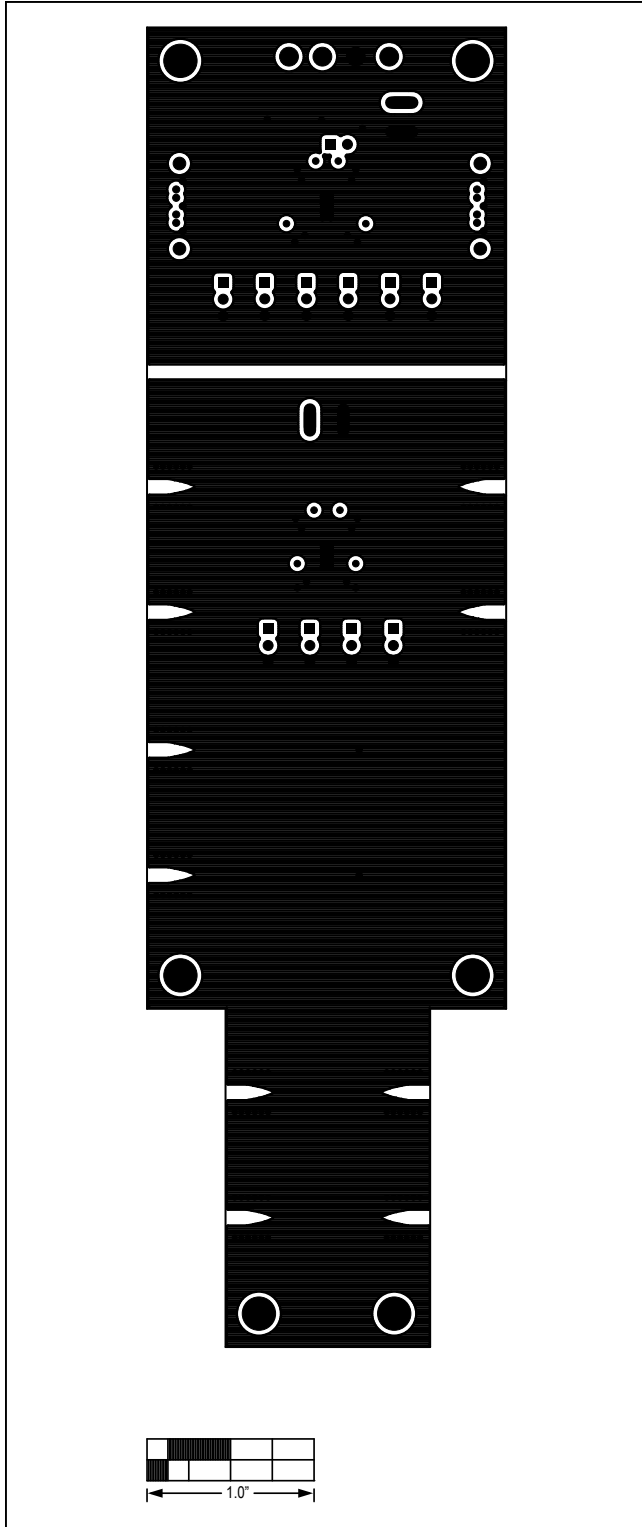

Figure 4. MAX14986 EV Kit PCB Layout—Inner Layer 2

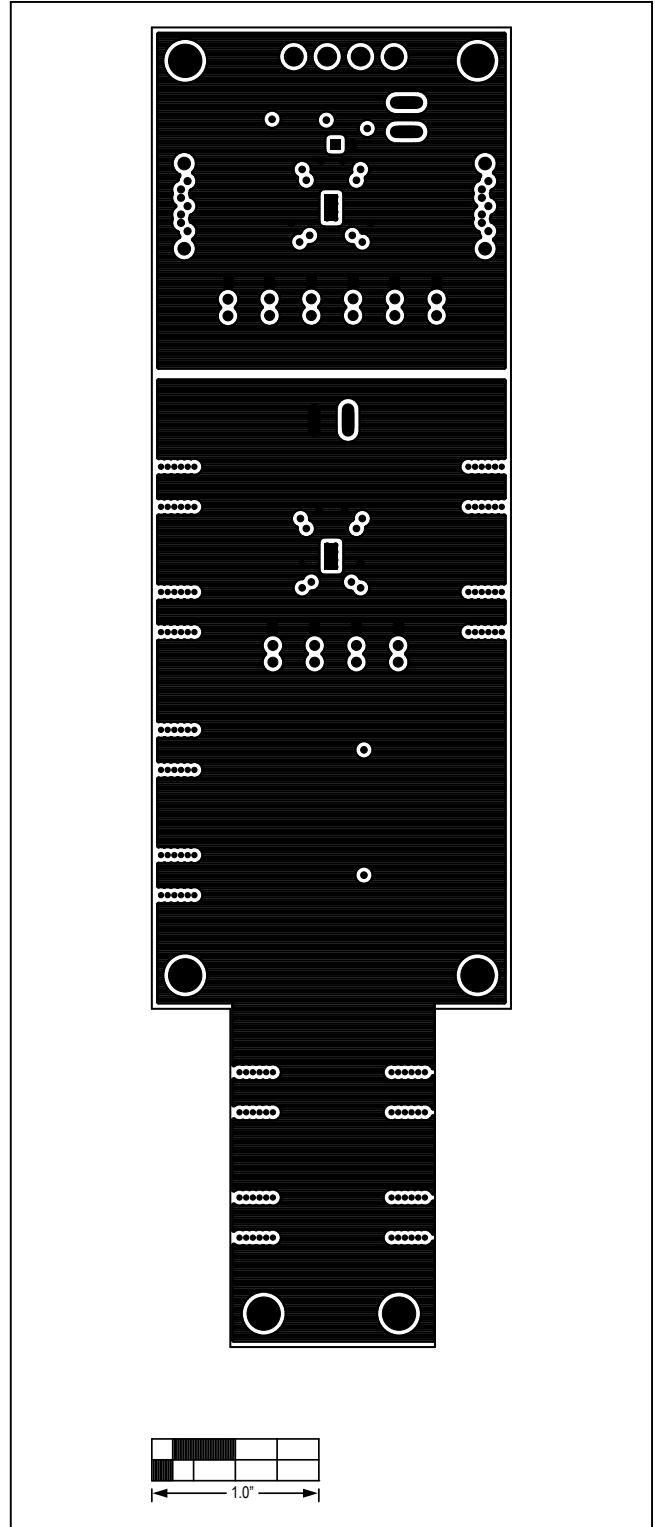

Figure 5. MAX14986 EV Kit PCB Layout—Inner Layer 3

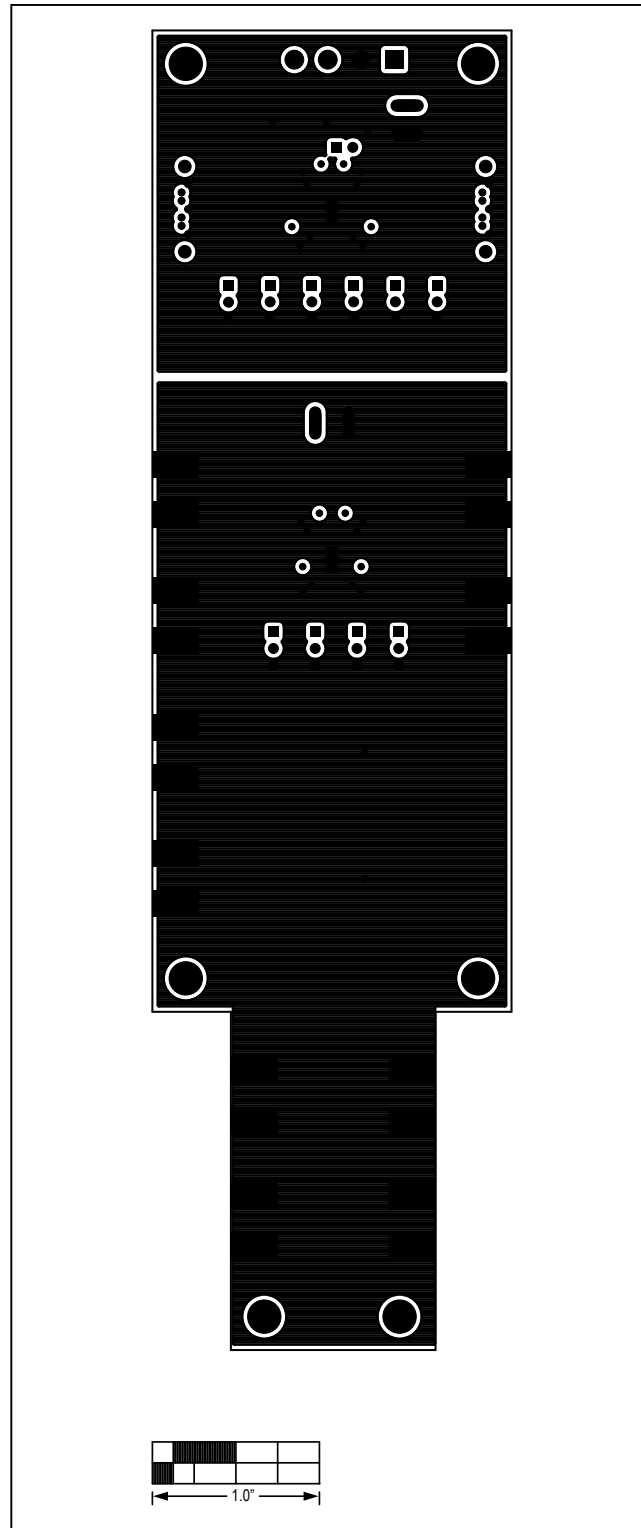

Figure 6. MAX14986 EV Kit PCB Layout—Solder Side

### Ordering Information

PART	TYPE
MAX14986EVKIT#	EV Kit

*#Denotes RoHS compliant.*

### Revision History

REVISION NUMBER	REVISION DATE	DESCRIPTION	PAGES CHANGED
0	11/13	Initial release	—

For pricing, delivery, and ordering information, please contact Maxim Direct at 1-888-629-4642, or visit Maxim Integrated's website at [www.maximintegrated.com](http://www.maximintegrated.com).

*Maxim Integrated cannot assume responsibility for use of any circuitry other than circuitry entirely embodied in a Maxim Integrated product. No circuit patent licenses are implied. Maxim Integrated reserves the right to change the circuitry and specifications without notice at any time.*