

NOTE 1 THIS PRODUCT IS DELIVERED SEPARATELY.  
 2 AS SHOWN IN THE FIGURE, THIS PRODUCT SHALL BE USED ASSEMBLED TO A CONNECTOR UNIT 'DH3+B-37S'.  
 A CLAMP 'DH-37-CMB(8.8)' IS NEEDED WHEN ASSEMBLING THE UNIT.  
 3 A RECOMMENDED SCREW TIGHTENING FOR COVERS TO BE FROM 0.1 TO 0.15 N·m.

3	STAINLESS STEEL	PLATING : NICKEL 0.1μm MIN.	6	STEEL	TRIVALENT BLACK CHROMATE
2	PC	UL94V-0 BLACK	5	PC	UL94V-0 BLACK
1			4	STAINLESS STEEL	
NO.	MATERIAL	FINISH . REMARKS	NO.	MATERIAL	FINISH . REMARKS
UNITS mm		SCALE 2 : 1	COUNT △	DESCRIPTION OF REVISIONS	
DESIGNED		CHECKED		DATE	
APPROVED : A0. SUZUKI 09.05.11			DRAWING NO. EDC3-126948-00		
CHECKED : KN. ICHIKAWA 09.05.11			PART NO. DH-37-CT2B		
DESIGNED : MO. SHIMOYAMA 09.05.11			CODE NO. CL244-0049-0-00		
DRAWN : MO. SHIMOYAMA 09.05.11			△ 1/2		

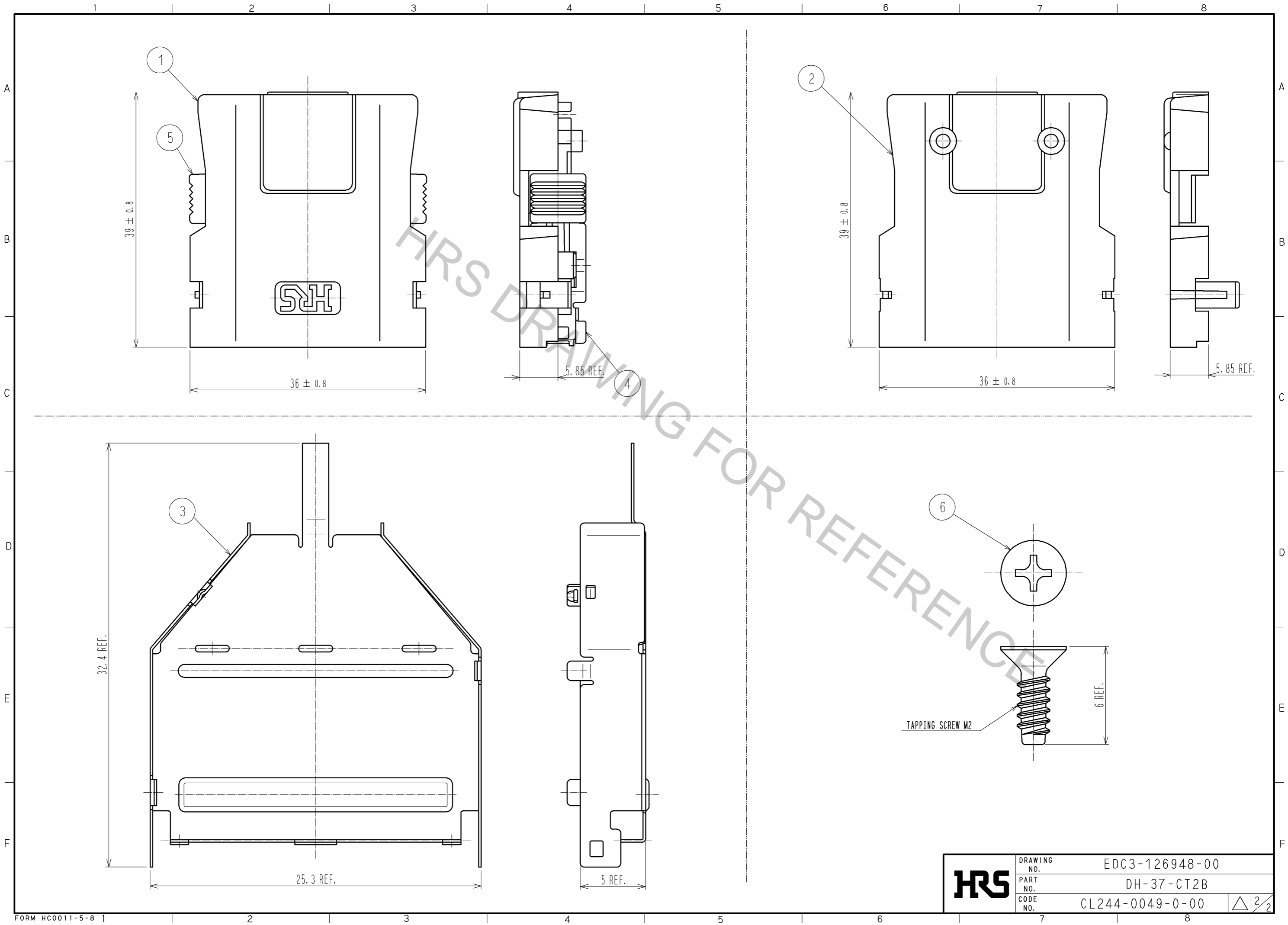

<b>HRS</b>	DRAWING NO.	EDC3-126948-00	△ 2/2
	PART NO.	DH-37-CT2B	
	CODE NO.	CL244-0049-0-00	