

THE MOTOR DRIVE CONTROLLER



MODEL MDC INSTRUCTION MANUAL

INTRODUCTION

The Motor Drive Controller (MDC) is another unit in our multi-purpose series of industrial control products that is field-programmable for solving various applications. This series of products is built around the concept that the end user has the capability to program different indication and control requirements.

The Motor Drive Controller which you have purchased, has the same high quality workmanship and advanced technological capabilities that have made Red Lion Controls the leader in today's industrial market.

Red Lion Controls has a complete line of industrial indication and control equipment, and we look forward to serving you now and in the future.



CAUTION: Read complete instructions prior to installation and operation of the unit.



CAUTION: Risk of electric shock.

TABLE OF CONTENTS

I. GENERAL DESCRIPTION	4-11
A) Safety Summary	4
B) Quick Start - Setting Up The MDC	5
C) Block Diagram	6
D) Theory of Operation	7
E) Normal Operating Mode	8
F) Keypad Description	9
1. Keypad Functions	9
G) Dedicated Control Inputs	10
H) Front Panel Accessible Programming	10
I) Overflow	11
II. PROGRAMMING GENERAL DESCRIPTION	12
III. USER SETPOINTS MODULE	13-15
A) User Setpoints In Master Mode	14
1. Speed Setpoint 1	14
2. Speed Setpoint 2	14
3. Ramp Rate 1	14
4. Ramp Rate 2	14
5. Jog Speed Setpoint	14
6. Jog Ramp Rate	14
7. Alarm 1 Setpoint	14
8. Alarm 2 Setpoint	14
9. Error Gain Setpoint	15
B) User Setpoints in Follower Mode	15
1. Ratio Setpoint 1	15
2. Ratio Setpoint 2	15
3. Ramp Rate 1	15
4. Ramp Rate 2	15
IV. PROGRAMMING MODULE	16-30
A) Operating Mode Selection Menu	16
B) Program Scaling Menu	17-18
1. Pulses per Revolution- Feedback	17
2. Maximum RPM- Feedback	17
3. Display Decimal Point	17
4. Display Units	17
5. Pulses per Revolution- Lead	18
6. Maximum RPM- Lead	18

TABLE OF CONTENTS (Cont'd)

IV. PROGRAMMING MODULE (Cont'd)	16-30
C) Program User Menu	19-21
1. No Mode	20
2. View Display	20
3. Change Display	20
4. Reset Alarms	20
5. Setpoint Select/Toggle	20
6. Ramp Select/Toggle	20
7. Ramp Override	20
8. Setpoint Increment	21
9. Setpoint Decrement	21
10. Program Disable	21
11. Run	21
12. Ramp Stop	21
13. Fast Stop	21
14. Jog	21
D) Program Alarms Menu	22-23
1. Alarm Types	22
a. High	22
b. Low	22
c. Deviation	22
d. Zero Speed	22
e. Disabled	22
2. Phase (+ or -)	23
3. Boundary or Latched	23
4. Normal or Fast Update Time	23
5. Stop Enabled or Disabled	23
E) Program Displays Menu	24-25
1. Displays 1 to 4	24
2. Scroll Speed	24
F) Program Options Menu	26-28
1. Operator Access	26
2. Feedback Loss Detection	26
3. User Settings	27
4. MDC Factory Settings	27
5. MDC User Setting Chart	28

TABLE OF CONTENTS (Cont'd)

IV. PROGRAMMING MODULE (Cont'd)	16-30
G) Program Diagnostics Menu	29-30
1. Test Inputs	29
2. Test Alarms	30
3. Test Drive Output	30
H) Program Security Menu	30
1. Select Security Code.....	30
VII. INSTALLATION & CONNECTIONS	31-38
A) Installation Environment.....	32
B) Terminal Connection Drawing	33
C) Wiring Connections.....	33
1. AC Power Wiring	33
2. DC Output Power Wiring.....	34
D) Signal Wiring	34-36
1. Lead & Feedback Frequency Inputs	34
2. Dedicated Function and User Inputs	35
3. Alarm Outputs 1 and 2	35
4. Drive Enable Output	35
5. Isolated Drive Output	36
E) DIP Switch Set-up	36
VIII. ISOLATED DRIVE OUTPUT CALIBRATION	39
A) Drive Output Span Calibration.....	39
B) Motor Drive Setup	39
C) Verify System Operation	39
D) Trim	39
IX. SPECIFICATIONS & DIMENSIONS	40-41
X. TROUBLESHOOTING	42-44
XI. APPENDIX “A” - APPLICATIONS	45-46
A) MASTER MODE APPLICATION	45
B) FOLLOWER MODE APPLICATION.....	46
XII. APPENDIX “B” - ORDERING INFORMATION	47
XIII. APPENDIX “C” - FLOWCHART FOLD-OUT (Insert)	-

GENERAL DESCRIPTION

The Motor Drive Controller (MDC) accurately regulates motor speed by varying an isolated DC control signal to a motor drive system. There are two modes of operation, Master and Follower.

Master Mode provides control of a motor directly via programmed speed setpoints in the MDC. Regulation is maintained by means of a feedback frequency to the MDC taken from the motor shaft or a downstream shaft pulse encoder. Follower Mode controls a motor's speed as a ratio to a second motor's speed or outside frequency source. The MDC is a "speed" follower. It does not track the lead motor's position. Ratio setpoints are programmed into the unit causing the motor to "follow" the lead motor's speed at a fixed ratio.

The MDC has two programmable speed setpoints and two ramp setpoints in master mode. Follower Mode has two ratio setpoints and two ramp setpoints. Both modes share a jog speed setpoint and a jog ramp setpoint. All setpoints are retained in non-volatile memory when the unit is powered down.

There are five dedicated control inputs on the MDC:

- RUN
- RAMP STOP
- FAST STOP
- JOG
- OPEN LOOP

There are six programmable control inputs: two front panel function keys and four remote User Inputs. The F1 and F2 keys are factory programmed for RUN and R-STOP respectively. This eliminates the need for external switches in some applications.

There are three solid state outputs, two are programmable and one is a dedicated DRIVE ENABLE output. Programmable functions include:

- HIGH ALARM
- LOW ALARM
- DEVIATION ALARM
- ZERO SPEED
- DISABLED

Outputs may be programmed for boundary or latching operation, and high or low acting. There are also two programmable alarm update rates, Normal and Fast.

Application flexibility is provided through the two-line by eight-character alphanumeric display. The display features English language menus for easy viewing and simplified programming. The four scroll-through Indication Displays can be programmed to show various parameters and to automatically scroll, if desired. A program disable DIP switch used with an external User Input can be utilized to protect the settings and guarantee that no unwanted changes occur during operation.

Changing speed setpoints and programming information is easily accomplished by scrolling through menus and selecting the correct parameter. There are three main Modules:

- INDICATION DISPLAY MODULE
- USER SETPOINTS MODULE
- PROGRAMMING MODULE

Scaling is accomplished by entering the number of feedback pulses per revolution (PPR), the maximum RPM, and the maximum display units. The MDC is factory configured for an isolated 0 to 10 VDC drive output signal. The drive output signal can be adjusted to span from 0 to a maximum of 5 through 15 VDC via an accessible potentiometer. The drive output is jumper selectable for an external reference voltage. To use the external reference, the MDC is connected to the drive in place of an external speed potentiometer.

The construction of the MDC unit is a lightweight, high impact plastic case with a clear viewing window. The sealed front panel with the silicone rubber keypad meets NEMA 4X/IP65 specifications for wash-down and/or dusty environments, when properly installed. Plug-in style terminal blocks simplify installation and wiring change-outs.

SAFETY SUMMARY

All safety related regulations, local codes and instructions that appear in the manual or on equipment must be observed to ensure personal safety and to prevent damage to either the instrument or equipment connected to it. If equipment is used in a manner not specified by the manufacturer, the protection provided by the equipment may be impaired.

Do not use this unit to directly command motors, valves, or other actuators not equipped with safeguards. To do so, can be potentially harmful to persons or equipment in the event of a fault to the unit.

QUICK START - SETTING UP THE MDC

While it is generally recommended that you read this instruction manual thoroughly before attempting to set up and operate the model MDC Motor Drive Controller, the following quick set-up procedure provides the basic steps to get the MDC up and running.

1. Read “General Description” and “Block Diagram” to familiarize yourself with the Basic Connections. (A/C, Inputs, Outputs, etc).
2. Wire or set the Control Inputs to their proper states:
 - RUN may be left open for front panel control, or wired to common through a momentary, normally OPEN switch for remote operation.
 - R-STOP may be tied to common for front panel control, or wired to common through a momentary, normally CLOSED switch for remote operation.
 - F-STOP must be tied to common or wired to common through a momentary, normally CLOSED switch.
 - JOG must be left open or wired to a momentary, normally OPEN switch requiring a sustained closure for Jog mode.
 - OPEN LOOP must be left open for normal closed loop control, or wired to a switch which can be maintained in the open or closed position, depending on User preference.

Refer to “Dedicated Control Function and User Inputs” in the “Installation and Connections” section for more information.

3. Set the AC power selection switch and connect AC to the MDC as noted in “AC Power Wiring” in the “Installation and Connections” section.
4. Review “Programming General Description” and “Keypad Description” to familiarize yourself with the Front Panel Programming procedure.
5. To set up the MDC for Master Mode - Program the scaling variables for PPR FB, MAX RPM FB, DSP DP, and DSP UNIT. Refer to the “Program Scaling Menu”.
6. To set up the MDC for Follower Mode - Select Follower Mode in the Operating Mode Selection Menu. Program the scaling variables for PPR FB, MAX RPM FB, DSP DP, and DSP UNIT. Refer to “Program Scaling Menu”. Pay particular attention to “Additional Scale Factors in Follower Mode”. This will explain the two additional required variables PPR LD and

RPM LD, which are part of setting the Unity Ratio. Understanding the Unity Ratio is crucial to scaling in Follower Mode.

7. Refer to “Isolated Drive Output Calibration” section to determine if the MDC Drive Output span needs to be calibrated. Most applications require calibration of the drive only. Calibrate the drive as noted in “Motor Drive Setup”.
8. Disconnect AC power. Wire the MDC to the motor drive. Refer to “Wiring from MDC to Motor Drive” in the “Installation and Connections” section.
9. Wire the FEEDBACK and LEAD (follower mode only) frequency inputs. Set the DIP Switches as required. Refer to the “Installation and Connections” section.
10. Apply power to the MDC and Drive.
11. To run the motor, connect the RUN Input to common momentarily or press the F1/RUN key, located on the Front Panel. The MDC will run the motor to the selected setpoint using the currently selected ramp rate. If the setpoint is changed during Run Mode using the Front Panel Keypad or a remote input, the MDC will either accelerate or decelerate the motor to the new setpoint using the current ramp rate.
12. To stop the motor, momentarily disconnect the R-Stop Input from common or press the “F2/STP” key, located on the Front Panel. The MDC will decelerate the motor using the currently selected ramp rate.
13. Disconnecting F-Stop momentarily from common will cause the MDC to take the Drive Output voltage immediately to zero volts. This will cause the motor to execute a Fast Stop uncontrolled by the ramp rate. If the F-Stop Input remains open from common, the Run and Jog inputs are disabled and the Drive Output voltage is fixed at zero volts. A maintained switch should be used on the F-Stop input if this type of lock out is desired.

BLOCK DIAGRAM

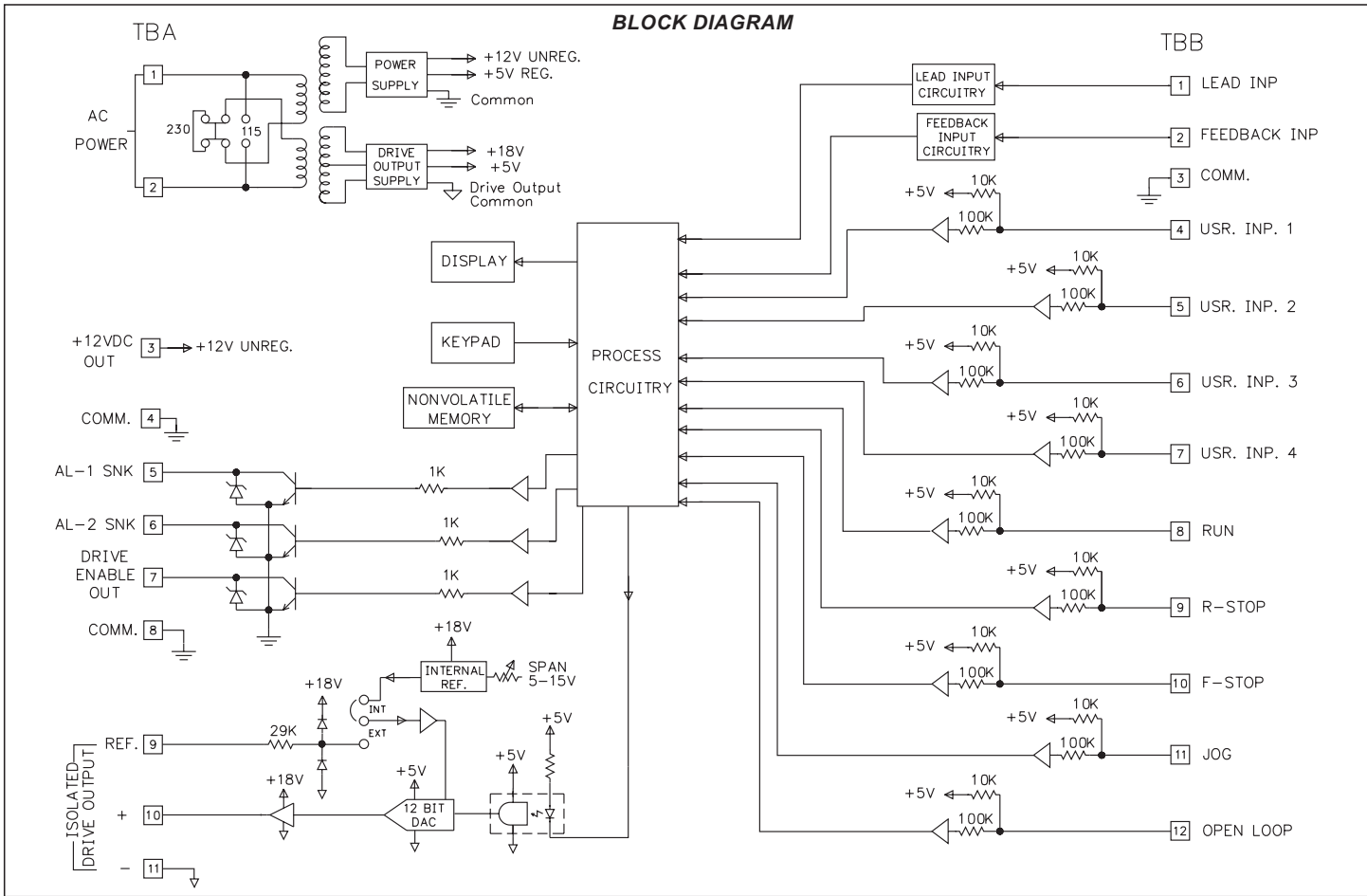

THEORY OF OPERATION

In Master Mode, the MDC uses actual motor speed (Feedback Input) and an analog control voltage (Drive Output) to precisely control the motor's speed. The MDC operates on a 10 msec control cycle. Actual motor speed is read and drive output is corrected every 10 msec. The Drive Output voltage is generated by a 12 bit DAC (digital to analog converter). Motor speed is controlled by adjusting the Output Value (in bits) to the DAC.

The Output Value (0 to 4095 bits) is made up of two parts, the Open Loop term, and the correction term or Trim Value. The Open Loop term is the ratio of the Reference Speed to Maximum Speed multiplied by 4095. This is the uncorrected "Feed Forward" part of the Output Value. The Reference Speed is the current Speed setpoint taking into account any acceleration or deceleration which may be in progress. The Maximum Speed is Max RPM Feedback which is set when scaling the unit. (See the Program Scaling section of the manual for more information.)

The correction term or Trim Value is derived from actual motor speed (Feedback Input) and the Reference Speed. The Trim Value is added to the Open Loop term when the MDC is running Closed Loop to provide precise control. The Error Gain determines the rate at which the Trim Value changes in response to a motor loading or a sudden speed change. The Trim Value is updated every 10 msec. It may be viewed as one of the programmable display options (see Program Displays Menu).

The Drive Output voltage is then the ratio of Output Value (in bits) to 4095 multiplied by the Full Scale Reference voltage. The internal Full Scale Reference is factory calibrated to 10 VDC but may be adjusted to any value within a 5 to 15 VDC range. An external reference option also exists. (See Isolated Drive Output section of manual for more information.)

In Follower Mode, the basic operation is the same except that the Reference Speed is generated as a ratio to the Lead Input speed. Also, the MDC operates on a 20 msec control cycle in order to process both Lead and Feedback input frequencies.

NORMAL OPERATING MODE

When the MDC is powered up, it is in the Normal Operating Mode with the Indication Display Module viewed. The up and down arrow keys are used to scroll through the Indication Displays. The Indication Displays are referenced as 1 to 4 with the factory default settings of 1 (SPEED), 2 (OPERATING STATUS), 3 (ALARM STATUS), and 4 (TRIM). The Indication Displays can be programmed to show other parameters and automatically scroll if desired (See Program Displays Menu for details). All Dedicated Function Inputs, User Inputs, and Alarm Outputs are operational in the Normal Operating Mode.

From the Normal Operating Mode, two other modules may be entered. The SET key enters the User Setpoints Module and the PGM key enters the Programming Module. The last display viewed when exiting the Indication Display Module will be the first display viewed upon return. Also, the last Indication Display viewed at power down, will be the one viewed on power up.

The User Setpoints Module may be accessed from any of the Indication Displays or from the Programming Module (with the exception of the Operating Mode Selection Menu). The Setpoints Module is used to set all of the user setpoints, such as speed, alarm, and gain values (see Programming User Setpoints). User Setpoints may be edited while the MDC is in a RUN or JOG mode.

The flowchart at right shows the three main Modules that are accessible in the Normal Operating Mode.

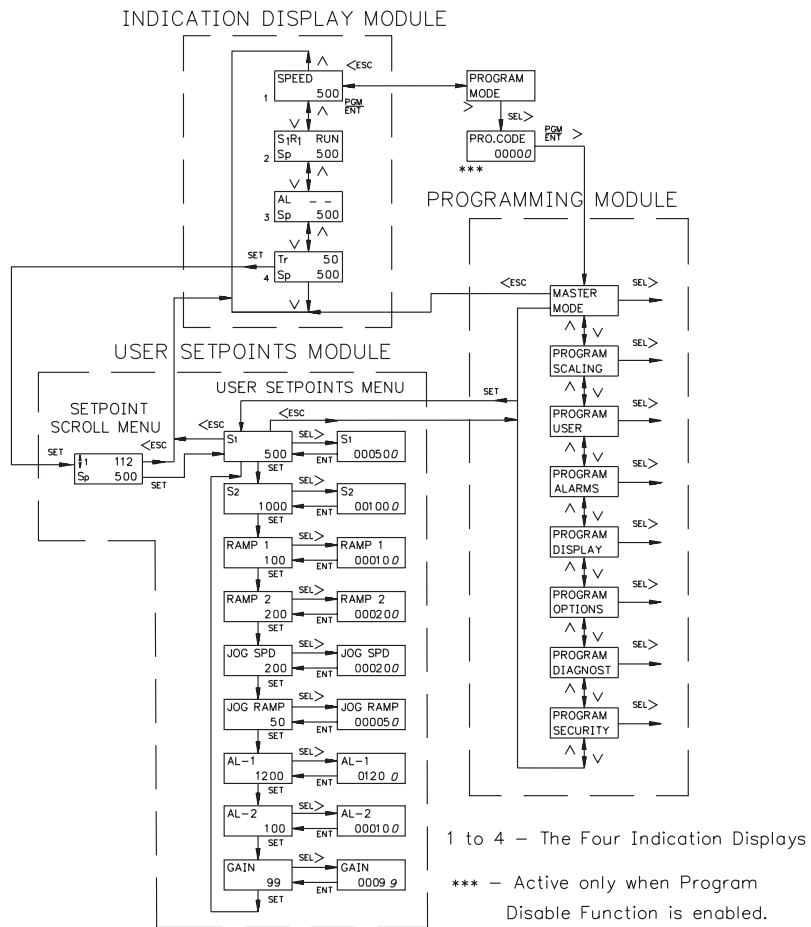

KEYPAD DESCRIPTION

Shown here is a diagram of the keypad and a description of each key. Some keys have a dual function.

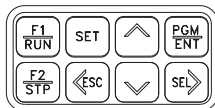

KEYPAD FUNCTIONS

- F1 RUN** - Function key F1/RUN is a User Programmable Input. When the key is pressed, the unit performs the appropriate function as programmed in the “Program User Menu”. The “RUN” printing on this key is used as a quick reference for the operator, when the function key is programmed for a “RUN” function.
- F2 STP** - Function key F2/STP is a User Programmable Input. When the key is pressed, the unit performs the appropriate function, as programmed in the “Program User Menu”. The “STP” printing on this key is used as a quick reference for the operator, when the function key is programmed for a “STOP” function.
- SET** - The SET key accesses the User Setpoints Module from any Indication Display or from the Programming Module (excluding the Mode Selection Menu). In the Setpoints Module, this key scrolls through the setpoint values.
- <ESC** - The Left arrow/escape key is used in multiple ways. When programming a numerical value, it selects the digit to the left. In a sub-menu, it exits to the next higher level menu in the loop. It is also used to exit the Programming Module and Setpoints Module. When exiting either Module, the MDC stores all parameters into nonvolatile memory and returns to the last viewed Indication Display. Setpoint 1 and 2 are stored in nonvolatile memory at power down.
- ^** - The Up arrow key scrolls through the Indication Displays. When in the User Setpoints Module, it is used to increment the current speed setpoint (Setpoint Scroll Menu), or to scroll through the setpoint values. In the Programming Module, it scrolls through the programming menus. When programming a numerical value, it increments the selected digit.

KEYPAD FUNCTIONS (Cont'd)

- V** - The Down arrow key scrolls through the Indication Displays. When in the User Setpoints Module, it is used to decrement the current speed setpoint (Setpoint Scroll Menu), or to scroll through the setpoint values. In the Programming Module, it scrolls through the programming menus and sub menus. When programming a numerical value, it decrements the selected digit.
- PGM ENT** - The Program/Enter key displays “Program Mode” when pressed in the Indication Display Module and initiates entry into the Programming Module. This key is also used to store a new value when a selection is made in an edit menu.
- SEL>** - The Select/Right arrow key selects the digit to the right when programming a numerical value. It is also used to enter the Programming Module from the “Program Mode” display. In a sub-menu loop, it is used to go to the next lower level and eventually into an edit menu.

DEDICATED CONTROL INPUT FUNCTIONS

The Motor Drive has inputs dedicated to certain primary operations. These functions are as follows:

RUN

A momentary closure to common on the RUN input causes the MDC to accelerate the motor from STOP mode to the current speed setpoint using the current ramp rate.

R-STOP

A momentary open from common on the R-STOP input causes the MDC to decelerate the motor from its current speed to STOP mode using the current ramp rate.

F-STOP

A momentary open from common on the F-STOP input causes the MDC to execute a fast stop, taking the analog Drive Output signal immediately to zero volts. Motor deceleration is limited only by the motor drive system. This is an emergency stop function. The Drive Enable Output goes immediately to its inactive state and may be used to engage braking or remove power from the motor via an external relay.

JOG

The jog function only operates from the STOP mode. A sustained closure from the JOG input to common causes the MDC to accelerate the motor to the jog speed setpoint using the jog ramp rate. The motor remains at the jog speed until the closure is removed, at which point the MDC executes an F-STOP.

OPEN LOOP

A maintained closure to common on this input causes the MDC to run open loop. The error correction value, Trim, is set to zero and speed is not regulated. A momentary closure on this input can be used as a Trim reset, to momentarily reset the Trim value to zero.

Note: Feedback Loss Detection is automatically disabled in Open Loop Mode.

FRONT PANEL ACCESSIBLE PROGRAMMING

The MDC has several ways to limit the programming of parameters in the User Setpoints Module and the Programming Module. The Operator Access Menu, in the Programming Module, can be used with the Program Disable (PGM. DIS) DIP switch or an external User Input to limit programming of parameters in the User Setpoints Module.

To enter the Programming Module, a program code number may need to be entered, depending on the Program Disable Function setting. Only external User Inputs can be selected for program disable. The default value for the program code number is "00", but should be programmed differently (See Program Security Menu). This helps prevent inadvertent entry into the unit's programming modules. When PROGRAM MODE is displayed and then the SEL key is pressed, the PRO.CODE prompt will be viewed. At this time, the Code number must be entered using the arrow keys. After selecting the proper code number and pressing the Enter key, the operator advances into the Programming Module. If the wrong code number is entered, the operator will not be able to enter the Programming Module and the unit returns to the PROGRAM MODE display. The following list describes the possible program disabling functions.

PGM.DIS SWITCH	USER INPUT TERMINAL	PROGRAM CODE NUMBER	ACTION
OFF	INACTIVE or Not Programmed for PGM.DIS	N/A	Complete programming enabled.
OFF	ACTIVE	0 to 98	Operator Accessible Functions, Programming Loop Accessible via Code number.
OFF	ACTIVE	99	Operator Accessible Functions, Programming Loop Disabled.
ON	INACTIVE or Not Programmed for PGM.DIS	0 to 98	Operator Accessible Functions, Programming Loop Accessible via Code number.
ON	INACTIVE or Not Programmed for PGM.DIS	99	Operator Accessible Functions, Programming Loop Disabled.
ON	ACTIVE	N/A	No Accessible Functions, Programming Disabled.

OVERFLOW INDICATION

An input frequency overflow occurs in the normal operating mode when the input frequency specifications are exceeded. The MDC continuously displays “FB FREQ OVERFLOW”, or “LD FREQ OVERFLOW” when the respective input frequency exceeds specifications.

A second type of overflow is an Indication Display overflow. The MDC flashes the word “OVERFLOW” in the appropriate display when the overflow condition occurs. A display overflow occurs if the capacity of the display is exceeded. This can occur when DSP UNIT (Maximum Display Units) is scaled near the limit and the motor speed exceeds the scale value MAX RPM FB (Maximum Feedback RPM). For example, if DSP UNIT is set to 99999 and MAX RPM FB is set to 1750, the SPEED display overflows if the motor exceeds 1750 RPM.

A third type of overflow occurs in the Program Scaling Menu. If a PPR (Pulses per Revolution) or MAX RPM value is entered which causes the Maximum Equivalent Frequency (FB or LD) to exceed 20971 Hz, a Scaling overflow occurs. The display flashes “OVFLW” in place of the numeric value and a new value is required. The equivalent frequency can be determined by:

$$\text{Maximum Equivalent Frequency} = \frac{\text{PPR} \times \text{MAX RPM}}{60}$$

PROGRAMMING GENERAL DESCRIPTION

Programming is done through the front panel keypad, which allows the user to enter into Main Menus, Sub-Menus, and Edit Menus. English language prompts, flashing parameter values, and the front panel keypad aid the operator during programming.

Although the unit has been programmed at the factory, the parameters generally have to be changed to suit the desired application. From the Indication Display Module, the Programming Module is entered by pressing the Program/Enter (PGM/ENT) key. This displays "PROGRAM MODE". Then press the Select (SEL) key to enter the Programming Module. The Up and Down arrows are used to scroll through the main menus. Pressing Select (SEL) from a main menu, allows the user to enter a Sub-Menu where parameter values can be viewed. Parameter values are changed and entered in the Edit Menu. There are two types of Edit Menus:

1. A Choice Edit Menu allows the operator to scroll through options by pressing the down arrow key until the desired option is viewed. The option is entered by pressing the PGM/ENT (enter) key, which returns the operator to the previous sub-menu. The operator can exit the Edit Menu WITHOUT making a selection by pressing the <ESC key.
2. In a Numerical Value Edit Menu, the operator uses the left or right arrow key to select a digit. The up and down arrow keys change the digit's value. When the appropriate numerical value is selected, it is entered by pressing the PGM/ENT (enter) key, which returns the operator to the previous sub-menu.

All parameter values changed in the Programming Module are saved when exiting the Module. The operator can exit the Programming Module from any of the main menus by pressing the <ESC key, which momentarily blanks the display while the parameter values are saved in non-volatile memory. Turning off power before exiting the Programming Module causes a loss of the new data values entered, and "CHECKSUM ERROR 1" appears on the display at the next unit power up. Press "ENT" then "SEL" to reenter the new values. The unit returns to the Indication Display that was last viewed. Shown at right is the Indication Display Module and the Main Programming Menus of the MDC unit.

Note: In all of the flowcharts that follow, slanted characters indicate a flashing value in the unit's display. These characters indicate the programmable options.

INDICATION DISPLAY MODULE

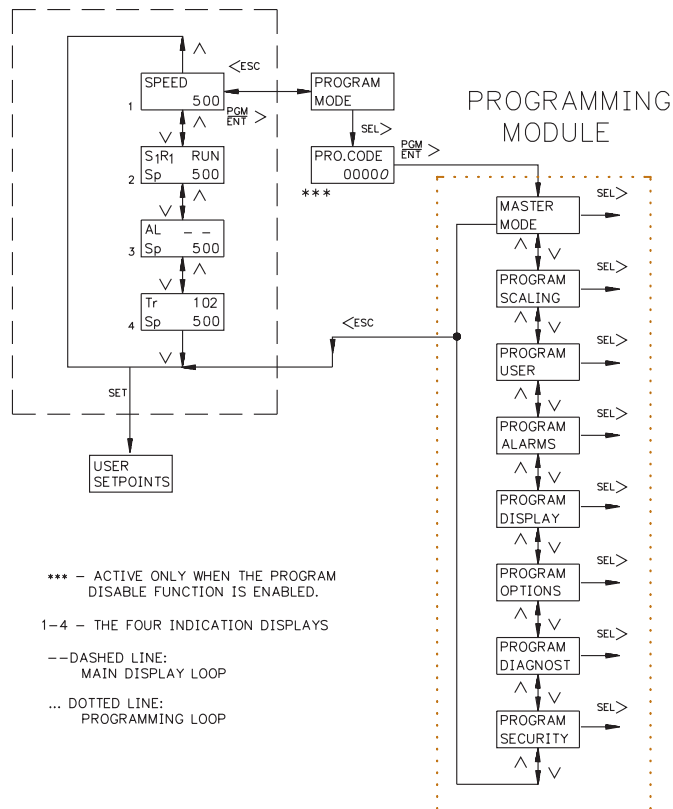

USER SETPOINTS MODULE

The User Setpoints Module is accessed from any of the Indication Displays, or from any of the main menus in the Programming Module (except Operating Mode Menu), by pressing the SET key.

Pressing "SET" once enters the Setpoint Scroll Menu. In this menu, the current speed or ratio setpoint may be incremented or decremented using the Up and Down arrow keys. The top line of the display shows the current setpoint value and the bottom line shows actual speed in display units.

Pressing "SET" a second time enters the User Setpoints Menu. The top line shows the Setpoint description and the bottom line shows the Setpoint value. The up and down arrow keys may be used to scroll through the loop. Pressing the SEL key allows the value to be changed in a Value Edit Menu. Press ESC to exit the User Setpoints Module.

The following flowchart shows only the User Setpoints portion:

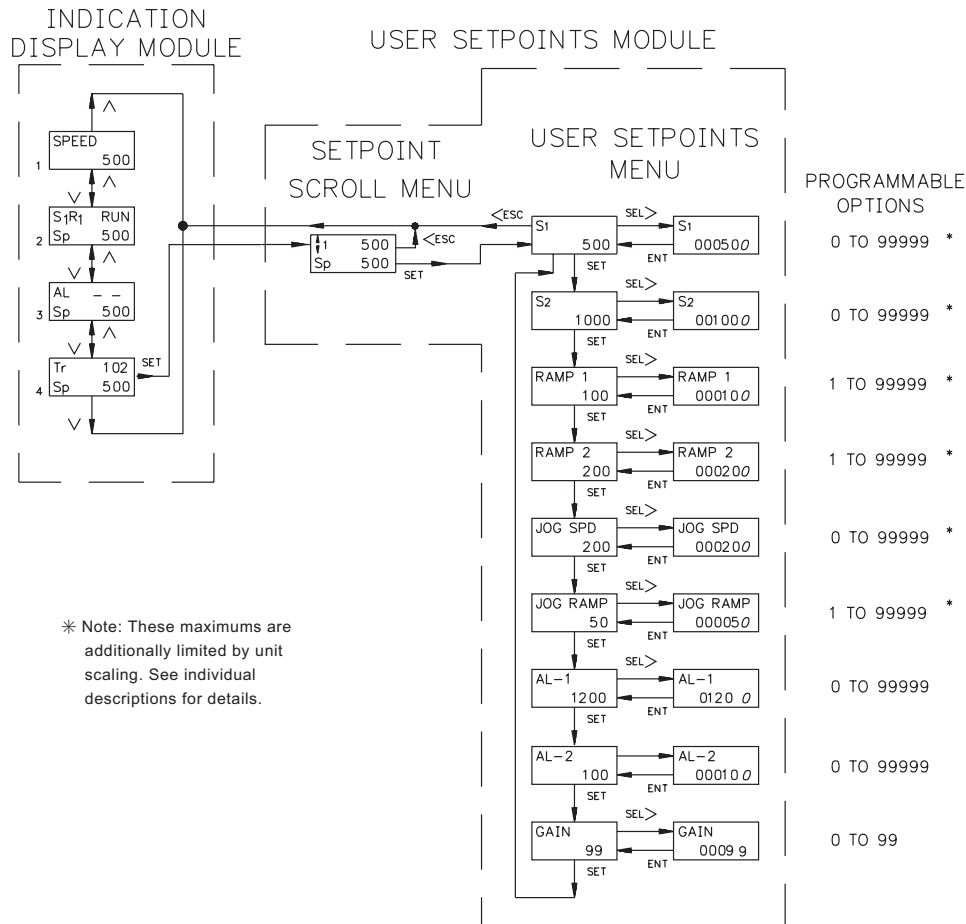

USER SETPOINTS IN MASTER MODE

Speed Setpoint 1 (S1)

Speed Setpoint 1 is one of two user selectable speeds used in “RUN” mode. The speed value is entered in display units (user units) as defined in the Program Scaling Menu. The value ranges from 0 to 99999, provided the Display Unit Maximum set in Program Scaling is 99999. Otherwise, the speed value is limited to the Display Unit Maximum. If a value greater than or equal to the Display Unit Maximum is entered, the message “MAX RPM LIMIT” flashes on the display and the maximum speed is automatically entered.

Speed Setpoint 2 (S2)

Speed Setpoint 2 is the second user selectable speed used in “RUN” mode. A User Input must be configured to allow selection of Setpoint 1 or 2 for use as the current speed setpoint. If no User Input is configured for setpoint selection (SPT SEL), the factory default setting is Speed Setpoint 1 (see Program User Menu for details).

Ramp Rate 1 (RAMP 1)

Ramp Rate 1 is used for acceleration and deceleration between “RUN” and “STOP” modes or between speed setpoints. The ramp rate value is entered in display units/second. For example, if the Display Units are RPM, then the ramp rate is RPM/SEC. The value ranges from 1 to 99999, provided that it is not greater than or equal to the internal limit of 20,000 feedback pulses per second. If this occurs, the message “MAX RAMP RATE” flashes on the display and the maximum ramp rate is automatically entered. A “0” value may be entered, which automatically selects the maximum ramp rate.

Ramp Rate 2 (RAMP 2)

Ramp Rate 2 is the second user selectable ramp rate. A User Input must be configured to allow selection of RAMP 1 or 2 for use as the current ramp rate. If no User Input is configured for ramp selection (RAMP SEL), the factory default setting is RAMP 1 (see Program User Menu for details).

Jog Speed (JOG SPD)

The Jog Speed setpoint is used in JOG mode (See JOG under Dedicated Control Input Functions for details). The value entered is in display units with the same range and limitations as Speed Setpoint 1.

Jog Ramp Rate (JOG RAMP)

The Jog Ramp Rate applies when entering JOG mode and accelerating to the Jog Speed. The value entered is in display units/sec. with the same range and limitations as Ramp Rate 1.

Alarm 1 (AL-1)

The Alarm 1 value is entered in display units. This value affects the Alarm 1 output. The alarm type is programmable and may be: High Speed, Low Speed, Deviation, or Zero Speed. A Zero Speed alarm has no Value Edit Menu. The value range for an alarm setpoint may be 0 to 99999, provided that it is not greater than the internal equivalent of 20971 feedback pulses per second. If this occurs, the message “SCALING LIMIT” is flashed on the display and the maximum value is automatically entered.

Alarm 2 (AL-2)

The Alarm 2 value affects the Alarm 2 output. It is programmable and has the same range and limitations as Alarm 1.

Error Gain (GAIN)

The Error Gain affects the closed loop response to a deviation from the speed setpoint. It has a value range of 0 to 99. A “0” entry eliminates correction for speed error. A “99” entry provides maximum correction for speed error and is the factory default setting. If instability or oscillation in motor speed occurs, this value should be reduced.

USER SETPOINTS IN FOLLOWER MODE

The setpoints listed below are independent FOLLOWER mode setpoints. They are retained separately from the MASTER mode setpoints in non-volatile memory. Jog, Alarm, and Gain values are shared parameters used by both MASTER and FOLLOWER modes.

Ratio Setpoint 1 (S1)

Ratio Setpoint 1 is one of two user selectable ratio setpoints used in “RUN” mode. The ratio value entered sets the follower motor’s speed as a ratio to the lead signal input. The range is 0.0000 to 1.9999.

Follower Speed (RPM) = Ratio Setpoint x Unity Ratio x Lead Speed (RPM)

A ratio setpoint of 1.0000 implies that the follower motor will run at the same speed as the lead motor if the Unity Ratio is 1.0. The unity ratio is determined by the values entered for MAX RPM FB and MAX RPM LD in the Program Scaling Menu.

Ratio Setpoint 2 (S2)

Ratio Setpoint 2 is the second user selectable Ratio setpoint. A User Input must be configured to allow selection of Setpoint 1 or 2 for use as the current Ratio setpoint. If no User Input is configured for setpoint selection (SPT SEL), the factory default setting is Setpoint 1. (See Program User Menu).

Ramp Rate 1 (RAMP 1)

Ramp Rate 1 is one of two user selectable ramp rates used for acceleration and deceleration between “RUN” and “STOP” modes or between ratio setpoints. The ramp rate value is entered in ratio units/second. The value ranges from 0.0001 to 1.9999 ratio units/sec. A value of 0.0000 may be entered to select the maximum ramp rate of 1.9999. This causes the message “MAX RAMP RATE” to be flashed on the display and the maximum ramp rate of 1.9999 to be automatically entered.

Ramp Rate 2 (RAMP 2)

Ramp Rate 2 is the second user selectable ramp rate. A User Input must be configured to allow selection of RAMP 1 or 2 for use as the current ramp rate. If no User Input is configured for ramp selection (RAMP SEL), the factory default setting is RAMP 1 (see Program User Menu).

PROGRAMMING MODULE

The Programming Module is used to access all parameters for configuring the unit. To enter the Programming Module, the user must first press PGM/ENT from the Indication Display Module. This causes “PROGRAM MODE” to be displayed. The user must then press SEL to enter the Programming Module. Depending upon the program disable state, access to the Programming Module may be denied or require a security code entry. (See Front Panel Accessible Programming.) The MDC will ramp to the STOP mode if you enter the Programming Module while the unit is in the RUN mode. The Display will flash “RAMPING DOWN” when the SEL key is pressed. The MDC must be in STOP mode before any programming changes can be made. While the unit is ramping down, F-STOP may be used to enter STOP mode immediately. The operation of the Dedicated Control Inputs and Alarm outputs is disabled while in the Programming Module, except as noted in the Program Diagnostics Menu.

OPERATING MODE SELECTION MENU

The Operating Mode Selection Menu indicates the MDC’s current operational mode. The factory default setting is MASTER mode. FOLLOWER mode may be selected by pressing SEL, DN arrow, and ENT. It is important to select the operational mode prior to scaling the MDC and entering User Setpoints. Setpoints S1, S2, Ramp 1, and Ramp 2 are speed units in MASTER mode and ratio units in FOLLOWER mode.

The following flowchart shows Operating Mode Selection only:

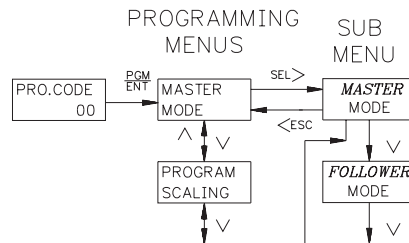

PROGRAM SCALING MENU

The Program Scaling Menu is used to scale the MDC to the specific motor (or shaft) feedback transducer output. This Menu also scales the speed in RPM to the Display units which are seen on the display and used for speed setpoint entry.

The following flowchart shows only the Scaling portion:

PROGRAMMING MENUS

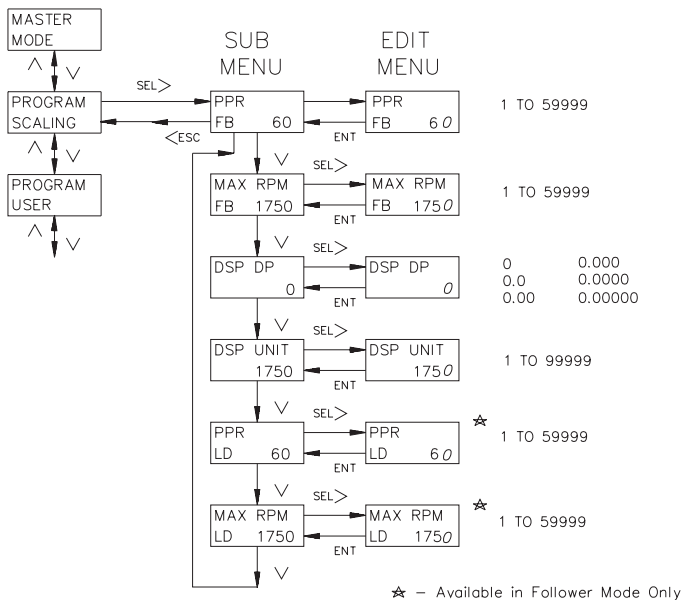

PPR FB (Pulses Per Revolution- Feedback)

Enter the number of pulses per revolution generated by the feedback transducer. The value for PPR FB ranges from 1 to 59999.

MAX RPM FB (Maximum RPM- Feedback)

Enter the maximum RPM for the feedback input transducer. This is the maximum normal operating speed (in RPM) of the motor (or shaft) which is generating the feedback signal. The value ranges from 1 to 59999.

Note: If the Maximum Equivalent Frequency exceeds 20971 Hz, "OVFLW" flashes over the numeric value and a new entry is required.

$$\text{Maximum Equivalent Frequency} = \frac{\text{PPR} \times \text{MAX RPM}}{60}$$

DSP DP (Display Decimal Point)

Select the display decimal point position. Press SEL and use the DN arrow key to select the decimal point position. The decimal point position is a place holder only and does not affect scaling. The available options are:

0
 0.0
 0.00
 0.000
 0.0000
 0.00000

DSP UNIT (Maximum Display Units)

Enter the value to be displayed when the motor (or shaft) is running at the speed entered for MAX RPM FB. This value is also the maximum allowable speed setpoint. The value ranges from 1 to 99999.

PROGRAM SCALING MENU (Cont'd)

ADDITIONAL SCALE FACTORS IN FOLLOWER MODE

PPR LD (Pulses Per Revolution- Lead)

Enter the number of pulses per revolution generated by the lead transducer. If an artificial frequency source is used, set PPR LD to 60. This SETS 1 RPM = 1 Hz. Max RPM Lead can then be entered in Hz. The value for PPR LD ranges from 1 to 59999.

MAX RPM LD (Maximum RPM- Lead)

This variable sets the unity ratio. Enter the desired RPM for the lead input transducer which would cause the follower motor (or shaft) to operate at MAX RPM FB when a ratio setpoint of 1.0000 is entered. The value for Max RPM LD does not need to be an actual operating maximum for the lead motor. It only sets the Unity Ratio.

Follower Speed (RPM) = Ratio Setpoint x Unity Ratio x Lead Speed (RPM)

Where:
$$\text{Unity Ratio} = \frac{\text{MAX RPM FB}}{\text{MAX RPM LD}}$$

This allows the user to define a 1:1 setpoint ratio which is different than the 1:1 speed ratio of the motors. The value entered for MAX RPM LD ranges from 1 to 59999.

Notes:

- 1. The maximum input frequency for Follower Mode is 12 kHz (lead and feedback).*
- 2. For optimum performance, choose the Motor Drive System with the highest frequency signal output as the master or lead system in a Follower Mode application.*

For example, in a Master/Follower application where two motors are driving conveyors which are feeding product into a hopper, conveyor A must run 2X faster than conveyor B to get a product mix of 1:1. The maximum speed for both motors is 1750 RPM. We will use motor B for the Follower since it runs slower than motor A. The max RPM feedback is set to 1750 (the max motor speed for conveyor B). Set the unity ratio so that a ratio setpoint of 1.0000 can be used to indicate a 1:1 ratio for the product mix, not the speed ratio of the motors. Since the lead motor (A) must run at a speed 2X the follower motor (B), set the max RPM Lead at a value 2X the follower motor max (3500 RPM). This will produce a follower speed 1/2 the lead speed when a 1.0000 ratio setpoint is selected. The value for max RPM Lead does not have to be an actual operating speed for the lead motor, this value simply sets the unity ratio.

MAX RPM FB = 1750

MAX RPM LD = 3500

$$\text{Unity Ratio} = \frac{\text{MAX RPM FB}}{\text{MAX RPM LD}} = \frac{1750}{3500} = 0.5$$

Using a Ratio Setpoint of 1.0000 and a Lead speed of 1750.

Follower speed = Ratio Stpt. x Unity Ratio x Lead speed (RPM)

Follower speed = 1 x 0.5 x 1750

Follower speed = 875

As you can see, the follower speed is half the lead speed when using a 1.0000 Ratio Setpoint. It is a good practice to set the Unity Ratio so a Ratio Setpoint of 1.0000 can be used as the normal operating setpoint. This will allow the operator to adjust the Ratio Setpoint in user units of product mix, not motor speeds.

PROGRAM USER MENU

There are four external User Inputs and two front panel Function keys, which have a variety of programmable capabilities. An external User Input is active when tied to common. A front panel function key is active when pressed. The options for each User input are the same, except as noted below:

1. The two Function keys (F1/RUN & F2/STP) have some additional functions: RUN (F1 only), R-STOP, F-STOP and JOG.

2. The two Function keys DO NOT have the Program Disable (PGM.DIS.) option.

The operator can select only one option for each User Input. The operator may enter a second sub-menu for some options before entering the edit menu. The following flowchart shows only the User portion:

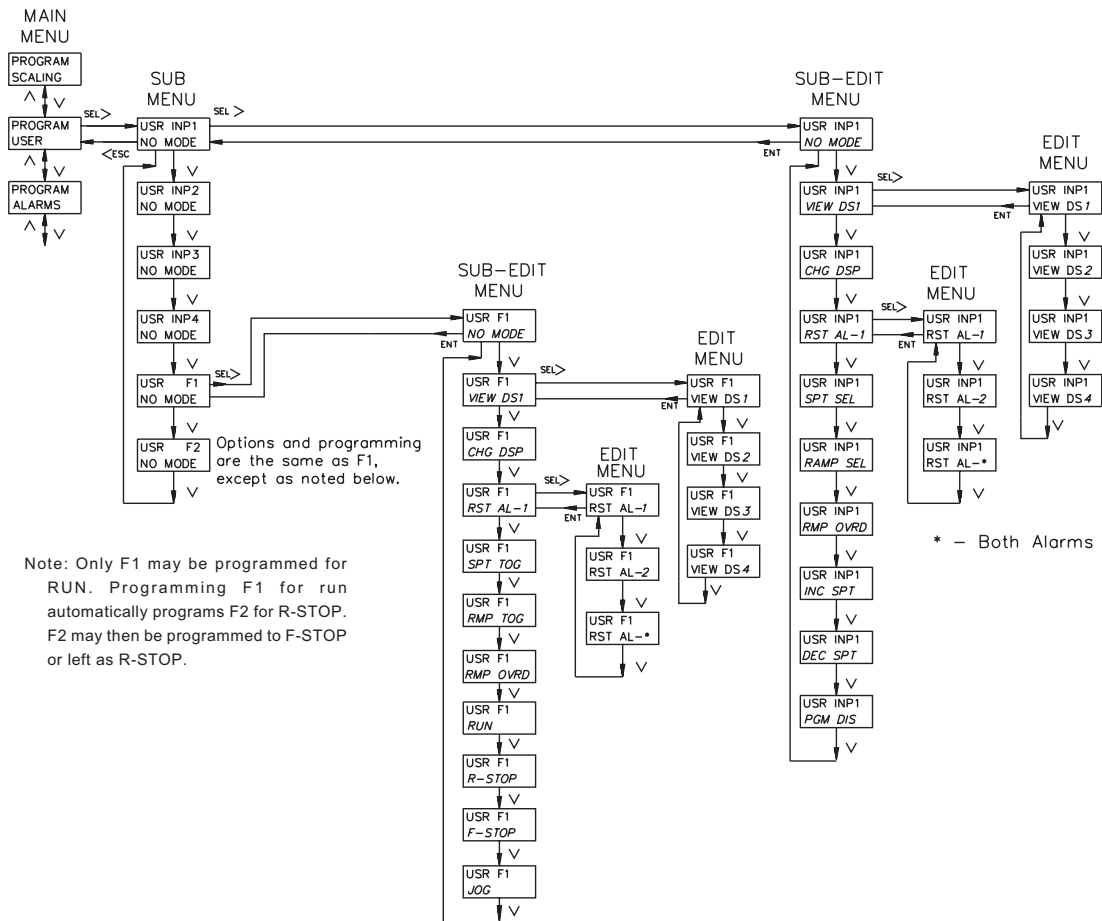

Note: Only F1 may be programmed for RUN. Programming F1 for run automatically programs F2 for R-STOP. F2 may then be programmed to F-STOP or left as R-STOP.

* - Both Alarms

PROGRAM USER MENU (Cont'd)

NO MODE

If a User Input terminal or a Function key is activated, it will be ignored.

VIEW DISPLAY (VIEW DS*n*)

In the Indication Display Module, the unit advances to the Indication Display selected, when the User Input is activated. In the User Setpoints Module or Programming Module, the unit advances to the selected display upon exiting that Module. DS1 selects display 1, DS2 display 2, DS3 display 3, and DS4 display 4. If an input is momentary the display is selected, but can be changed by use of the up or down arrow keys, or another User Input. If an input is maintained the display cannot be advanced using the UP and DN arrow keys on the keypad. If more than one User Input is used for this option, the priority order from highest to lowest is F2, F1, USR INP4, USR INP3, USR INP2, and USR INP1. The items viewed on the display are determined by what is selected in the Program Displays Menu.

CHANGE DISPLAY (CHG DSP)

In the Indication Display Module, when a User Input is activated, the Indication Display advances to the next Indication Display, this is a momentary action. If the operator is in the User Setpoint Module or the Programming Module, the unit advances to the next display upon exiting that Module.

RESET ALARM 1 OUTPUT (RST AL-1)

The operator can select to have Alarm Output 1, 2, or * (both) reset. If the output is active, it resets to its inactive state when the User Input or function key is activated. This may be a momentary or maintained action. A momentary action resets the alarm but it becomes active again within 10 msec if the alarm trigger condition still exists. A maintained action keeps the alarm reset regardless of the trigger condition.

Note: The Inactive state of an output can be ON or OFF depending on what is programmed in the Program Alarms Menu.

SETPOINT SELECT/TOGGLE (SPT SEL/TOG)

ONLY ONE USER INPUT SHOULD BE PROGRAMMED FOR SPT SEL/TOG. If more than one is programmed, the highest priority input is recognized and all of the others are ignored. The priority order from highest to lowest is USR INP4, USR INP3, USR INP2, USR INP1, F1/F2.

Select

The MDC uses S1 (setpoint 1) for its factory default speed or ratio setpoint. If the User Input is made active, the MDC ramps to S2 at the current ramp rate. Making the input inactive causes the unit to ramp to S1. This is a maintained setpoint select for User Inputs 1 through 4.

Toggle

For F1 or F2, this is a momentary action causing a setpoint toggle between S1 and S2.

RAMP SELECT/TOGGLE (RAMP SEL/TOG)

ONLY ONE USER INPUT SHOULD BE PROGRAMMED FOR RAMP SEL/TOG. If more than one is programmed, the highest priority input is recognized and all of the others are ignored. The priority order from highest to lowest is USR INP4, USR INP3, USR INP2, USR INP1, F1/F2.

Select

The MDC uses R1 (ramp 1) for its factory default ramp rate for both acceleration and deceleration. If the User Input is made active, the MDC uses R2. Making the input inactive causes the unit to use R1. This is a maintained ramp select for User inputs 1 through 4.

Toggle

For F1 or F2, this is a momentary action causing a ramp toggle between R1 and R2.

RAMP OVERRIDE (RAMP OVRD)

Making this input active overrides the acceleration/deceleration ramp routine causing the unit to jump to the ramp endpoint. This may be a setpoint change or STOP condition. A momentary action overrides the current ramp in process. A maintained action overrides the current ramp in process and all future ramps.

Caution: Significant overshoot of the speed setpoint can occur with this feature.

SETPOINT INCREMENT (INC SPT)

Only an external User Input can be used for this option. The currently active speed or ratio setpoint is incremented when the User Input is made active. If the input remains active for more than 5 display unit increments, the scroll rate will progressively increase.

SETPOINT DECREMENT (DEC SPT)

Only an external User Input can be used for this option. The currently active speed or ratio setpoint is decremented when the User Input is made active. If the input remains active for more than 5 display unit increments, the scroll rate will progressively increase.

PROGRAM DISABLE (PGM.DIS.)

Only an external User Input can be used for this option. When used with the Program Disable DIP switch, this option can limit operator access to programmable parameters (see Front Panel Accessible Programming With Program Disable section). The program disable is maintained.

Additional Options Available For F1 & F2 Keys

RUN

Activation of a function key selected for RUN causes the MDC to accelerate the motor from STOP mode to the current speed setpoint using the current ramp rate.

RAMP STOP

Activation of a function key selected for R-STOP causes the MDC to decelerate the motor from its current speed to STOP mode using the current ramp rate.

FAST STOP

Activation of a function key selected for F-STOP causes the MDC to execute a fast stop, taking the analog Drive Output signal immediately to zero volts. Motor deceleration is limited only by the motor drive system. This is an emergency stop function. The Drive Enable Output goes immediately to its inactive state and may be used to engage braking or remove power from the motor via an external relay.

JOG

The jog function only operates from the STOP mode. Pressing and holding a function key selected for JOG causes the MDC to accelerate the motor to the jog speed setpoint using the jog ramp rate. The motor remains at the jog speed until the function key is released, at which point the MDC executes an F-STOP.

PROGRAM ALARMS MENU

Alarm parameters 1 and 2 activate solid state Alarm Outputs 1 and 2 respectively. A manual reset, which requires the use of a User Input, will reset an Alarm Output (see Program User Menu). Both alarms may be programmed for any of the five alarm functions: High Alarm, Low Alarm, Deviation Alarm, Zero Speed Alarm, and Disabled. The following flowchart shows only the Alarms portion:

ALARM TYPES

High Alarm (HIGH ALM)

The alarm output activates when the feedback input registers a speed greater than or equal to the alarm value in display units.

Low Alarm (LOW ALM)

The alarm output activates when the feedback input registers a speed less than or equal to the alarm value in display units. The alarm may be active or inactive in stop mode (see Stop Enabled or Disabled).

Deviation Alarm (DEV ALM)

The alarm output activates when the feedback input registers a speed outside of a \pm band around the current speed or ratio setpoint. The band is equal to the \pm alarm value in display speed units. The alarm may be active or inactive in stop mode (see Stop Enabled or Disabled).

For Example: A speed setpoint of 1000, with an alarm setpoint of 10 would activate the alarm when the speed fell below 990 or went above 1010.

Zero Speed Alarm (ZERO SPD)

The alarm output activates when the feedback input receives no input pulse for at least 1 second. There is no alarm value associated with the Zero Speed Alarm.

Disabled

The alarm output is inactive when disabled.

PROGRAMMING MENUS

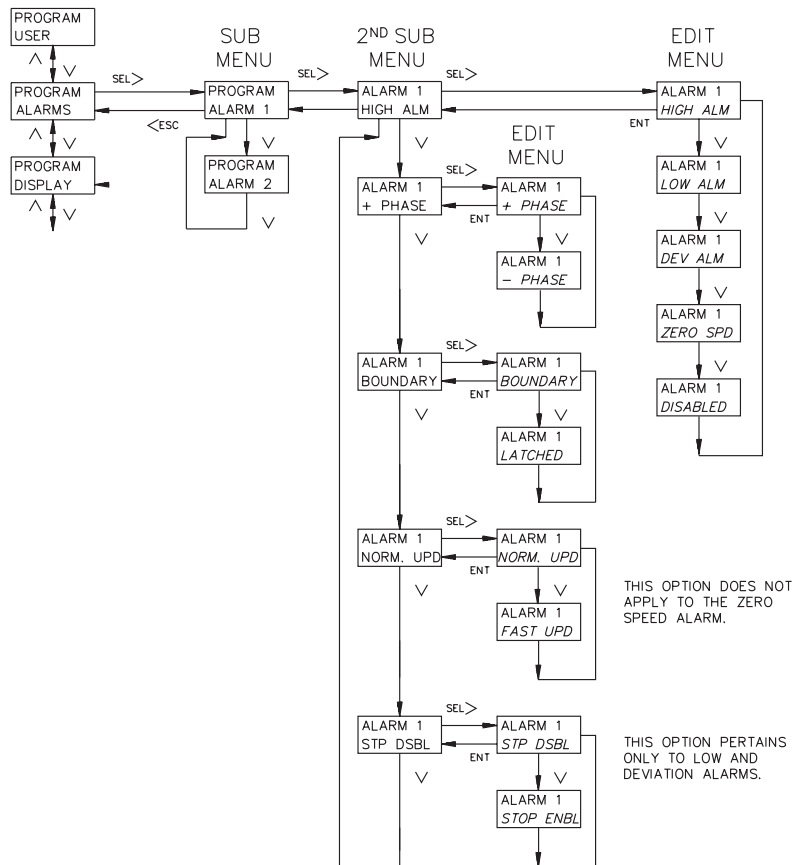

Phase

The positive (+) phase of an output indicates that when the alarm becomes active, the output turns on. When the output is reset it is turned off.

The negative (-) phase of an output indicates that when the alarm becomes active, the output turns off. The reset condition of the output is the on state.

Boundary or Latched

An alarm programmed for Boundary Output becomes active as determined by the alarm type (High, Low, Deviation, or Zero Speed). The output stays active as long as this alarm trigger condition exists, after which the output returns to its inactive state. A maintained reset on a User Input programmed for Reset Alarm causes the alarm to stay in its inactive state at all times (see Program User Menu).

An alarm programmed for Latched Output becomes active as determined by the alarm type (High, Low, Deviation, or Zero Speed). The output stays active until it is manually reset by a User Input selected for that function. A momentary reset causes the output to return to its inactive state provided that the condition causing the alarm no longer exists. A maintained reset on a User Input programmed for Reset Alarm causes the alarm to stay in its inactive state at all times (see Program User Menu).

Normal or Fast Update

The Normal update for the alarm outputs is once each second. This is the same as the Speed or Ratio display update. The calculation to check for the alarm condition is made from an average value of feedback measurements taken over a 1 second period.

The Fast alarm update occurs at an interval less than or equal to 40 msec. The calculation to check for the alarm condition is made from a single feedback and/or lead frequency measurement. Since no average is made, peaks caused by pulse encoder non-linearity (such as differences in the spacing of teeth on a gear or an unbalanced shaft) can cause the alarm to trigger early. THE FAST UPDATE SHOULD ONLY BE USED WHEN FAST RESPONSE IS NECESSARY.

Stop Enabled or Disabled

This is an option that pertains only to the Low alarm and Deviation alarm. It refers to the alarm function when the MDC is in STOP mode or ramping to or from STOP mode. When the alarm is Stop Enabled, the alarm functions normally in stop mode. A low alarm would always be on since zero speed is always less than or equal to the speed setpoint.

When the alarm is programmed to be Stop Disabled, the alarm is always inactive in stop mode and when ramping to or from stop mode. The alarm can only become active after the speed setpoint value has been attained in Master Mode, or when the ramp up to the setpoint ratio is complete in Follower Mode.

PROGRAM DISPLAYS MENU

Each line of each Indication Display can be programmed individually to show mnemonics or a numeric value for: Speed/Ratio Setpoint 1 or 2, Speed, Ratio, % Deviation, % Output, Feedback Frequency, Lead Frequency, Alarm 1 or 2 setpoint and Trim. Or, each line may be programmed to one of the two status displays: Operating Status or Alarm Output status. If an Indication Display is to show two different numeric values, one for each line, there will be a single or dual character mnemonic to the left of the numeric value. This will also be true if one line is programmed for operating status or alarm output status. The flowchart on the following page shows only the Display portion:

DISPLAYS 1 TO 4

Each line of each display has the same programmable options. MNE is the abbreviation for Mnemonics and VAL is for Value. The following list shows the single or dual character mnemonics that will be displayed when VAL is selected and the full mnemonic when MNE is selected:

VAL	MNE	DESCRIPTION
S1 99999	SETPT. 1	Speed or ratio setpoint 1
S2 99999	SETPT. 2	Speed or ratio setpoint 2
Sp 99999	SPEED	Actual speed in user display units (feedback)
R 1.999	RATIO	Actual feedback to lead input speed ratio (follower mode)
%D 100.0	% DEV.	% deviation of actual speed from target speed
%O 100.0	% OUTPUT	Analog drive output- % of full scale voltage
FB 20971	FB. FREQ	Feedback frequency in pulses/sec (Hz.)
LD 12000	LD. FREQ	Lead frequency in pulses/sec (Hz.)
A1 99999	ALARM 1	Alarm 1 setpoint
A2 99999	ALARM 2	Alarm 2 setpoint
Tr 4095	TRIM	Error correction in bits (-4095 to +4095) (See Isolated Drive Output Calibration section)

Status displays:

Operating Status

(setpoint 1, ramp rate 1, Run mode)

Alarm Output Status

(alarm 1 inactive, alarm 2 active)

```
S1 ↑1 RUN
AL - 2
```

Operating Status

(setpoint 1, ramp rate 1, Stop mode)

Alarm Output Status

(alarm 1 active, alarm 2 inactive)

```
S1 R1 STP
AL 1 -
```

Operating Status

The operating status display indicates the currently active speed or ratio setpoint (S1 or S2), the currently active ramp rate (R1 or R2), and the mode of operation (RUN, STP, or JOG). An arrow will replace the "R" for the currently active ramp rate indication when an actual ramp up or down is in progress.

Alarm Status

The alarm status display indicates that an alarm output is active when the corresponding output number (1 or 2) is displayed. When an alarm output is inactive, a dash is displayed.

SCROLL SPEED (SCRO.SPD)

The Indication Displays can be set to scroll automatically at a 2.5 or 5 second scroll rate. Automatic display scrolling can also be set to NONE, in which case the up and down arrow keys are used to scroll through the displays.

PROGRAMMING MENUS

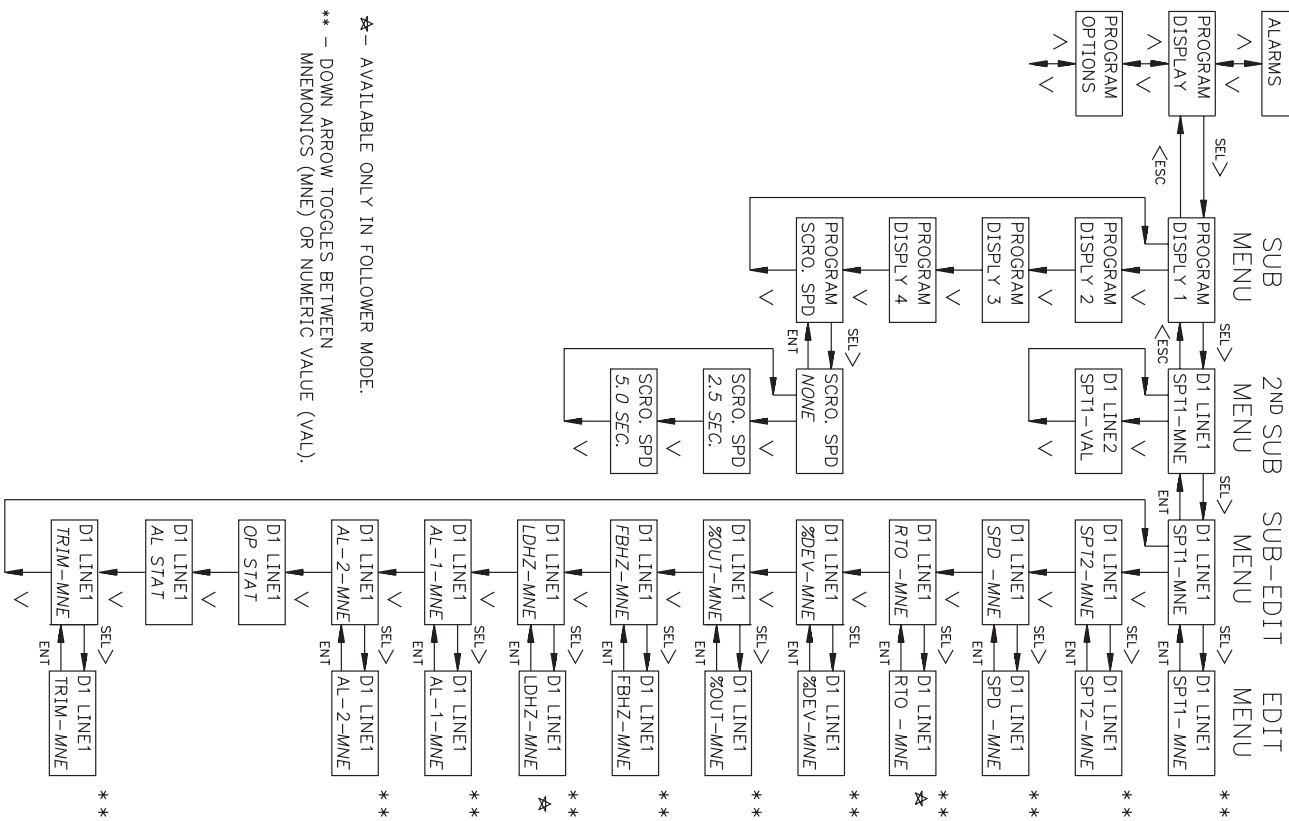

★ - AVAILABLE ONLY IN FOLLOWER MODE.

** - DOWN ARROW TOGGLES BETWEEN MNEMONICS (MNE) OR NUMERIC VALUE (VAL).

PROGRAM OPTIONS MENU

The Program Options Menu is used to enable or disable the operator accessible functions, load the Factory Settings, or enable/disable No Feedback Detection.

The following flowchart shows only the Options portion:

OPERATOR ACCESS

The Operator Access menu is used with the program disable DIP switch or an external User Input that is selected for the program disable function. When an option is selected as NO, the operator can view the option but CANNOT change the numeric value from the front panel keypad. (Refer to Front Panel Accessible Programming With Program Disable for details.) The following setpoint values can be disabled from front panel access programming; Speed/Ratio Setpoint 1 and 2, Ramp Rate 1 and 2, Jog Speed, Jog Ramp, Alarm Setpoint 1 and 2, and Gain.

The Setpoint Scroll Menu may also be disabled in the Operator Access Menu. When disabled, the Setpoint Scroll Menu is not displayed.

Note: If a speed or ratio setpoint is disabled, the Setpoint Scroll Menu is not accessible when that setpoint is the currently active speed/ratio setpoint.

FEEDBACK LOSS DETECTION (NO FBACK DET)

Used to prevent the MDC from ramping a motor to full speed if the feedback signal is lost during operation or not present when RUN mode is invoked. As soon as the MDC detects a loss of feedback, the display shows "NO FEEDBACK" and the unit begins ramping down to zero speed. Enter "YES" to enable and "NO" to disable Feedback Loss Detection.

Note: Feedback Loss Detection is automatically disabled in Open Loop Mode.

PROGRAMMING MENUS

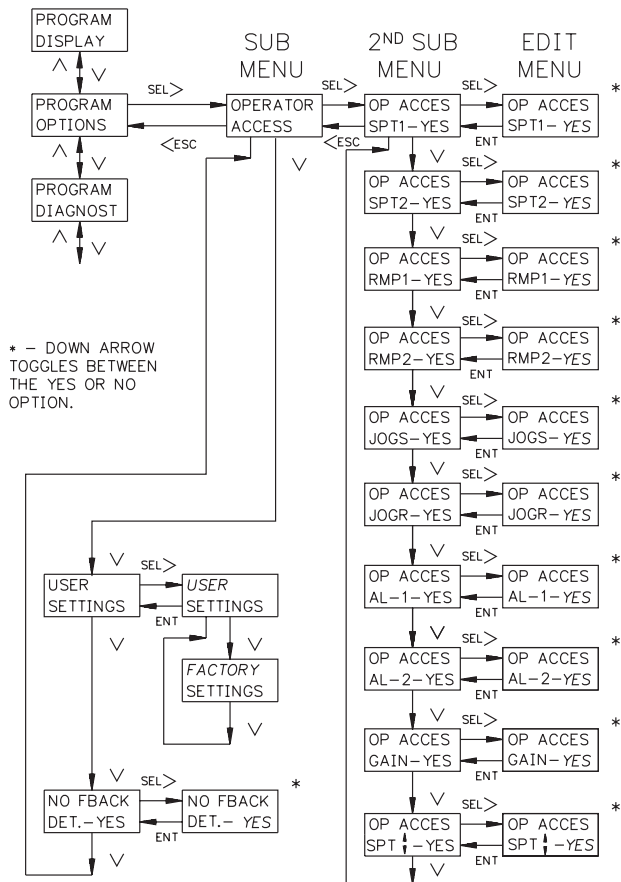

USER SETTINGS

This Menu should only be entered if the operator wants to reset ALL parameters in either Master or Follower mode to the factory settings. If the MDC is in Master Mode when the word “FACTORY” is flashing in the display and the ENT key is pressed, all parameters for that mode are reset to the factory settings upon exiting the Programming Module. The same is true for Follower Mode. Parameters common to both Master and Follower modes

FACTORY SETTINGS

MASTER MODE:		FOLLOWER MODE:	
USER SETPOINTS:		USER SETPOINTS:	
S1	500	S1	1.0000
S2	1000	S2	0.5000
R1	100	R1	0.1000
R2	200	R2	0.2000
DISPLAY 1		DISPLAY 1	
LINE 1	SPD-MNE	LINE 1	SPD-MNE
LINE 2	SPD-VAL	LINE 2	SPD-VAL
DISPLAY 2		DISPLAY 2	
LINE 1	OP STAT	LINE 1	OP-STAT
LINE 2	SPD- VAL	LINE 2	SPD-VAL
DISPLAY 3		DISPLAY 3	
LINE 1	AL STAT	LINE 1	LDHZ-VAL
LINE 2	SPD -VAL	LINE 2	FBHZ-VAL
DISPLAY 4		DISPLAY 4	
LINE 1	TRIM-VAL	LINE 1	TRIM-VAL
LINE 2	SPD -VAL	LINE 2	SPD-VAL
		SCALING:	
		PPR LD	60
		MAX RPM LD	1750

are reset regardless of the operating mode. The operator can exit the factory settings option WITHOUT resetting all parameters by pressing the <ESC key. The following are the settings when shipped from the factory, along with a chart for user settings:

Caution: *If factory settings are selected, all programming by the user for that operating mode will be reset.*

FACTORY SETTINGS COMMON TO MASTER AND FOLLOWER MODES:

USER SETPOINTS:		OPTIONS:	
JOG SPD	200	Operator Access:	
JOG RAMP	50	S1	YES
AL-1	1200	S2	YES
AL-2	100	R1	YES
GAIN	99	R2	YES
		JOG SPD	YES
SCALING:		JOG RAMP	YES
PPR FB	60	AL-1	YES
MAX RPM FB	1750	AL-2	YES
DSP DP	0	GAIN	YES
DSP UNIT	1750	SPT SCROLL	YES
USER INPUTS:		No Feedback Detection:	YES
User Input 1	NO MODE		
User Input 2	NO MODE		
User Input 3	NO MODE		
User Input 4	NO MODE		
User Key F1	RUN		
User Key F2	R-STOP		
ALARM OUTPUTS:			
ALARM 1:			
Alarm Type	HIGH ALM		
Phase	+ PHASE		
Latched/Boundary	BOUNDARY		
Update	NORM UPD		
ALARM 2:			
Alarm Type	LOW ALM		
Phase	+ PHASE		
Latched/Boundary	BOUNDARY		
Update	NORM UPD		
Stop Mode Status	STP DSBL		
DISPLAY:			
Scroll Speed	NONE		

USER SETTINGS

MASTER MODE:

USER SETPOINTS:

S1 _____
 S2 _____
 R1 _____
 R2 _____

DISPLAY 1

LINE 1 _____
 LINE 2 _____

DISPLAY 2

LINE 1 _____
 LINE 2 _____

DISPLAY 3

LINE 1 _____
 LINE 2 _____

DISPLAY 4

LINE 1 _____
 LINE 2 _____

FOLLOWER MODE:

USER SETPOINTS:

S1 _____
 S2 _____
 R1 _____
 R2 _____

DISPLAY 1

LINE 1 _____
 LINE 2 _____

DISPLAY 2

LINE 1 _____
 LINE 2 _____

DISPLAY 3

LINE 1 _____
 LINE 2 _____

DISPLAY 4

LINE 1 _____
 LINE 2 _____

SCALING:

PPR LD _____
 MAX RPM LD _____

FACTORY SETTINGS COMMON TO MASTER AND FOLLOWER MODES:

USER SETPOINTS:

JOG SPD _____
 JOG RAMP _____
 AL-1 _____
 AL-2 _____
 GAIN _____

SCALING:

PPR FB _____
 MAX RPM FB _____
 DSP DP _____
 DSP UNIT _____

ALARM OUTPUTS:

ALARM 1:
 Alarm Type _____
 Phase _____
 Latched/Boundary _____
 Update _____

ALARM 2:

Alarm Type _____
 Phase _____
 Latched/Boundary _____
 Update _____
 Stop Mode Status _____

DISPLAY:

Scroll Speed _____

USER INPUTS:

User Input 1 _____
 User Input 2 _____
 User Input 3 _____
 User Input 4 _____
 User Key F1 _____
 User Key F2 _____

OPTIONS:

Operator Access:

S1	YES	NO
S2	YES	NO
R1	YES	NO
R2	YES	NO
JOG SPD	YES	NO
JOG RAMP	YES	NO
AL-1	YES	NO
AL-2	YES	NO
GAIN	YES	NO
SPT SCROLL	YES	NO

No Feedback Detection: YES NO

PROGRAM DIAGNOSTICS MENU

This Menu allows testing of the various MDC inputs and outputs. It is especially useful after unit installation to independently test the operation of external switches, relays, the feedback transducer, and the motor drive system.

The following flowchart shows only the Diagnostics portion:

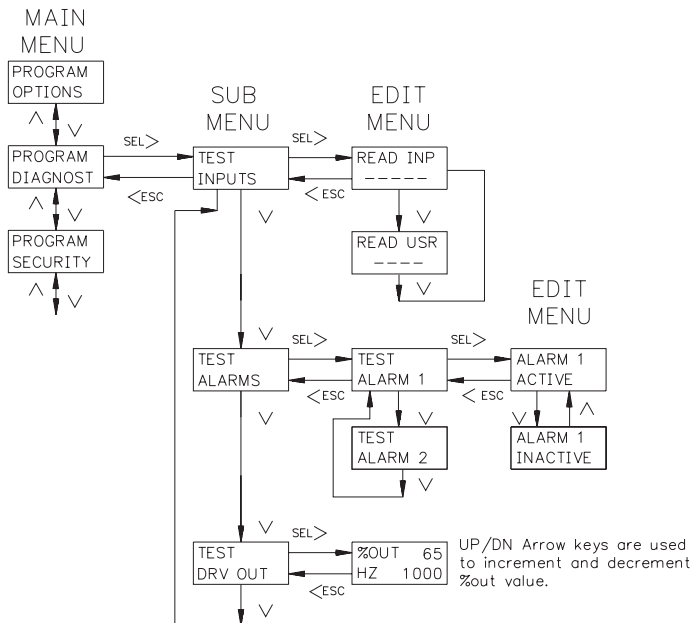

TEST INPUTS

The MDC displays an alphanumeric character to indicate a Dedicated Function Input or a User Input is active. This allows the user to check switch operation and wiring connections to the Inputs. It is made up of two sections. READ INP (read inputs) shows the state of the dedicated control inputs. READ USR (read user) shows the state of the programmable User Inputs. A "--" displayed on line 2 indicates that the input is inactive and an alphanumeric character indicates that the input is active. All of the inputs except F-STOP and R-STOP are active when pulled to common. F-STOP and R-STOP are active when left floating.

R=RUN, S=RAMP STOP, F=FSTOP, J=JOG, O=OPEN LOOP

READ INP

(all inactive)

READ INP

READ INP
RSFJO
(all active)

READ INP
RSFJO

READ USR

(all inactive)

READ USR

READ USR
1234
(all active)

READ USR
1234

The User Input is indicated by the number shown.

PROGRAM DIAGNOSTICS MENU (Cont'd)

TEST ALARMS

The up and down arrow keys are used to select an alarm output and set it to the active or inactive state. This allows the user to check the operation of devices wired to the alarm outputs and the wiring connections. Please note that the active state is defined by the PHASE programming in the Program Alarms Menu.

TEST DRIVE OUTPUT (TEST DRV OUT)

This function allows the user to test the Drive System. A % Output value is entered through the front panel keypad causing the motor to run at the corresponding speed. The display indicates the motor's feedback frequency. The Up and DN arrows set the percentage analog output. The percentage of analog output is shown on line 1 of the display. The feedback frequency in Hz is shown on line 2. Pressing F2/STP sets the % output to zero immediately. Pressing ESC zeros the % output and exits to the previous menu.

Note: The F-STOP input must be held low or tied to common before a % output value can be entered.



%OUT 100
HZ 1750

PROGRAM SECURITY MENU

This is used to select the PRO.CODE used for Program Mode access when either the PGM.DIS. DIP switch is on or a User Input programmed for the program disable function is active (see Front Panel Accessible Programming). The value shown on the display is the current PRO. CODE. The factory default value is 0. A new value may be entered in the range of 0 to 98. Entering a value of 99 will disable future entry into Programming Module when the Program Disable DIP switch or a User Input terminal set for Program Disable is active.

The following flowchart shows only the Security portion:

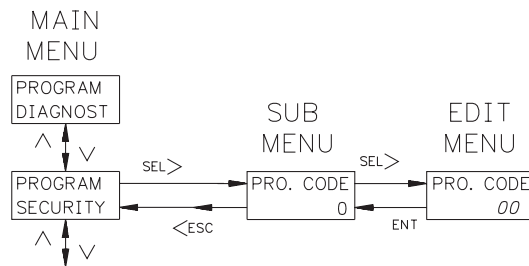

INSTALLATION & CONNECTIONS

Installation Environment

Before installing the MDC into the panel, the user should first become familiar with the unit. Also, it may be desirable to program the unit and set the appropriate DIP switches for the application. When programming is complete, all parameters are saved in non-volatile memory. The Program Disable DIP switch used with an external User Input, set for the program disable function, provides various levels of security to prevent accidental or

unauthorized programming changes. The MDC should be installed in a location that does NOT exceed the maximum operating temperature and provides good air circulation. Placing the unit near devices that generate excessive heat should be avoided.

The bezel should be cleaned only with a soft cloth and neutral soap product. Do NOT use solvents. Continuous exposure to direct sunlight may accelerate the aging process of the bezel.

Do not use tools of any kind (screwdrivers, pens, pencils, etc.) to operate the keypad of the unit.

Installation

The unit meets NEMA 4X/IP65 requirements for indoor use when properly installed. The units are intended to be mounted into an enclosed panel with a gasket to provide a watertight seal. Two mounting clips and screws are provided for easy installation. Consideration should be given to the thickness of the panel. A panel that is too thin may distort and not provide a watertight seal. (Recommended minimum panel thickness is 1/8" [3.2 mm]). The recommended clearance behind the panel for mounting clip installation is 3.0" (6.45 cm) H x 4.0" (10.16 cm) W.

After the panel cut-out is completed and deburred, carefully apply the gasket to the panel.

DO NOT APPLY THE ADHESIVE SIDE OF THE GASKET TO THE BEZEL.

Insert the unit into the panel as depicted in the drawing. Thread the screws into the clips until the pointed end just protrudes through the other side. Install each mounting clip by inserting the case tabs of the clip into the holes located on either side of the bezel.

Then snap the rear end of the clip into the case and slide the clip towards the rear of the unit, locking it in place. Tighten the screws evenly to apply uniform compression, thus providing a watertight seal.

Caution: Only minimum pressure is required to seal the panel. Do NOT overtighten mounting screws.

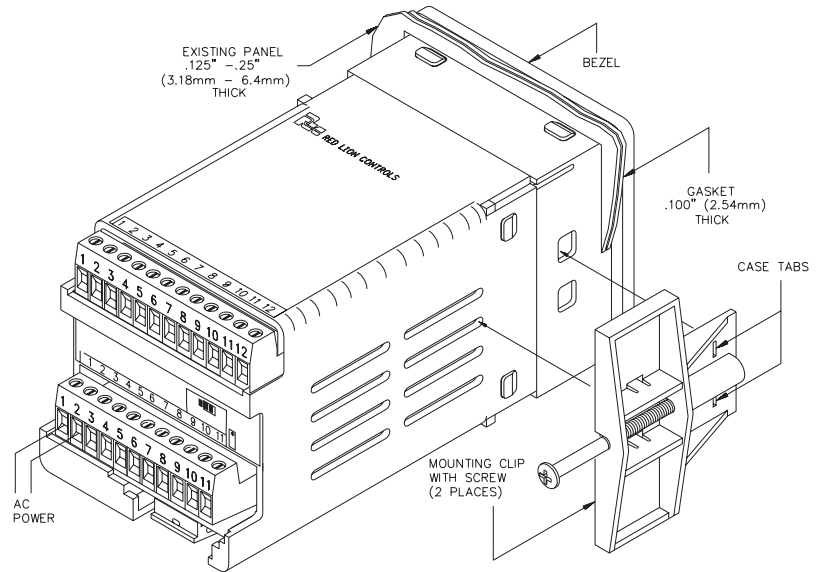

EMC INSTALLATION GUIDELINES

Although this unit is designed with a high degree of immunity to ElectroMagnetic Interference (EMI), proper installation and wiring methods must be followed to ensure compatibility in each application. The type of the electrical noise, source or coupling method into the unit may be different for various installations. It should be noted that the methods listed below may not be necessary for every unit installation. In extremely high EMI environments, additional measures may be needed. The unit becomes more immune to EMI with fewer I/O connections. Cable length, routing and shield termination are very important and can mean the difference between a successful or a troublesome installation. Listed below are some EMC guidelines for successful installation in an industrial environment.

1. Use shielded (screened) cables for all Signal and Control inputs and outputs. The shield (screen) pigtail connection should be made as short as possible. The connection point for the shield depends somewhat upon the application. Listed below are the recommended methods of connecting the shield, in order of their effectiveness.
 - a. Connect the shield only at the panel where the unit is mounted to earth ground (protective earth).
 - b. Connect the shield to earth ground at both ends of the cable, usually when the noise source frequency is above 1 MHz.
 - c. Connect the shield to common of the unit and leave the other end of the shield unconnected and insulated from earth ground.
2. Never run Signal or Control cables in the same conduit or raceway with AC power lines, conductors feeding motors, solenoids, SCR controls, and heaters, etc. The cables should be run in metal conduit that is properly grounded. This is especially useful in applications where cable runs are long and portable two-way radios are used in close proximity or if the installation is near a commercial radio transmitter.
3. Signal or Control cables within an enclosure should be routed as far away as possible from contactors, control relays, transformers, and other noisy components.
4. In extremely high EMI environments, the use of external EMI suppression devices, such as ferrite suppression cores, is effective. Install them on Signal and Control cables as close to the unit as possible. Loop the cable through the core several times or use multiple cores on each cable for additional protection. Install line filters on the power input cable to the unit to suppress power line interference. Install them near the power entry

point of the enclosure. The following EMI suppression devices (or equivalent) are recommended:

Ferrite Suppression Cores for signal and control cables:

Fair-Rite#0443167251 (RLC#FCOR0000)

TDK # ZCAT3035-1330A

Steward #28B2029-0A0

Line Filters for input power cables:

Schaffner#FN610-1/07 (RLC#LFIL0000)

Schaffner # FN670-1.8/07

Corcom #1VB3

Corcom #1VR3

Note: Reference manufacturers instructions when installing a line filter.

5. Long cable runs are more susceptible to EMI pickup than short cable runs. Therefore, keep cable runs as short as possible.
6. Switching of inductive loads produces high EMI. Use of snubbers across inductive loads suppresses EMI.
Snubbers:
RLC #SNUB0000

WIRING CONNECTIONS

When wiring the unit, remove the terminal block and use the numbers on the top label to identify the position number with the proper function. All conductors should meet voltage and current ratings for each terminal. Also cabling should conform to appropriate standards of good installation, local codes and regulations. It is recommended that power supplied to the unit be protected by a fuse or circuit breaker. Strip the wire, leaving approximately $\frac{1}{4}$ " bare wire exposed (stranded wires should be tinned with solder). Insert the wire into the terminal and tighten down the screw until the wire is clamped in tightly. Each terminal can accept up to two 18-gage wires. After the terminal block is wired, install it in the proper location at the rear of the unit. Wire each terminal block in this manner.

AC POWER WIRING

The AC power is connected to the bottom terminals, TBA 1 & 2, marked AC PWR. The voltage selector switch, located at the side of the unit, is used to select the proper voltage. The switch is a slide movement type and can be set using a small screwdriver. If the switch is towards the front of the unit, it is set for 115 VAC input. If the switch is towards the rear of the unit, it is set for 230 VAC input. The switch is in the 230 VAC position when shipped from the factory.

Note: Before applying power to the unit make sure the AC power switch is set for the proper voltage setting.

To reduce the chance of noise spikes entering the AC line and affecting the unit, the AC power should be relatively “clean” and within the specified $\pm 10\%$ variation limit. Connecting power from heavily loaded circuits or circuits that also power loads that cycle on and off, (contactors, relays, motors, etc.) should be avoided.

TERMINAL CONNECTIONS

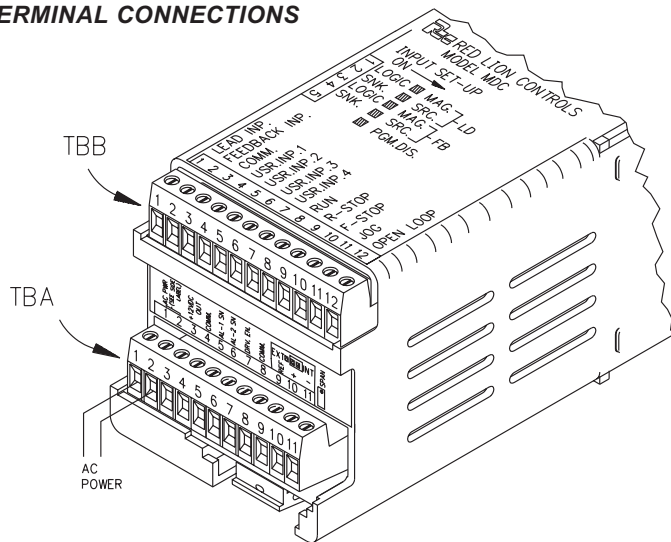

DC OUTPUT POWER WIRING

The DC Output power connections are bottom terminals TBA 3 & 4 marked +12 VDC and common. This source is capable of supplying 12 VDC $\pm 25\%$ at 100 mA to power input sensors or other external devices. These terminals **CANNOT** be used to supply DC power to the MDC.

SIGNAL WIRING

LEAD AND FEEDBACK FREQUENCY INPUTS

The Lead and Feedback Inputs have identical input circuitry. The Lead and Feedback inputs each have separate DIP switches for setting the type of signal input. A Magnetic Pickup or Logic Input signal can be sent to either input. When a MAGNETIC PICKUP is used, the Sink/Source DIP switch, for the appropriate input, must be in the "SRC" position for the frequency to be detected.

The Input schematic shows the details of the Lead and Feedback input circuitry. Both inputs share the same common. Each input has two DIP switches associated with it. The functions of these switches are as follows:

LEAD INPUT

SW1 - MAG: Sets input for a Magnetic Pickup signal.

Sensitivity: 200 mV peak;

Hysteresis: 100 mV

LOGIC: Sets input for a Logic signal.

Input trigger levels: $V_{IL} = 1.5 \text{ V max}$; $V_{IH} = 3.75 \text{ V min}$.

Note: SW2 Must be in the "SRC" position for a Magnetic Pickup signal.

SW2 - SNK: Provides a 7.8 K Ω internal pull-up resistor for sensors with current sinking outputs.

SRC: Provides a 3.9 K Ω internal pull-down resistor for sensors with current sourcing outputs.

FEEDBACK INPUT

SW3 - Same as SW1

SW4 - Same as SW2

Note: SW4 must be in the "SRC" position for a Magnetic Pickup signal.

Note: A Magnetic Pickup type sensor should not be used unless a large enough signal is provided at all speeds of operation.

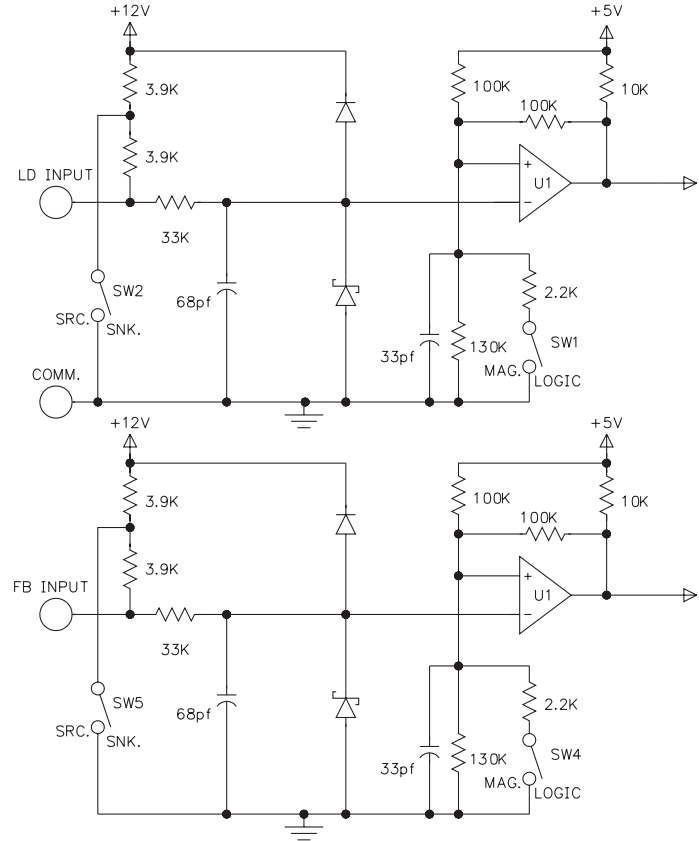

DEDICATED FUNCTION AND USER INPUTS

Refer to the Terminal Connections drawing. TBA is the bottom terminal block and TBB is the top terminal block.

RUN (TBB8): A momentary closure to common on the RUN input causes the MDC to accelerate the motor from STOP mode to the current speed setpoint using the current ramp rate.

- R-STOP (TBB-9) and F-STOP (TBB-10) must be held low or tied to common (TBB-3).
- MDC must be in the Indication Display or User Setpoints Module.
- MDC may not be in JOG mode.

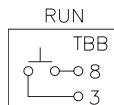

R-STOP (TBB9): A momentary open from common on the R-STOP input causes the MDC to decelerate the motor from its current speed to STOP mode using the current ramp rate.

- MDC must be in RUN mode. R-STOP is inoperative in JOG mode.

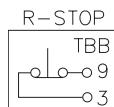

F-STOP (TBB10): A momentary open from common on the F-STOP input causes the MDC to execute a fast stop, taking the analog Drive Output signal immediately to zero volts. The motor deceleration is limited only by the motor drive system. This is an emergency stop function. The drive Enable Output goes immediately to its inactive state and may be used to engage braking or remove power from the motor via an external relay.

- F-STOP overrides all other active function inputs for as long as the F-STOP input remains active. The function priority from highest to lowest is: F-Stop, Jog, R-Stop, and Run. To lock out all other input functions, use a maintained switch on the F-Stop input.

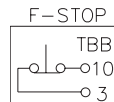

F-STOP is operative in RUN and JOG modes and the Program Diagnostics Menu.

Note: This does not guarantee that the drive is disabled unless the Drive Enable Output is used with an external relay to disconnect AC drive power.

JOG (TBB11): The jog function is only available from the STOP mode. A sustained closure from the JOG input to common causes the MDC to accelerate the motor to the jog speed setpoint using the jog ramp rate. The motor will remain at the jog speed until the closure is removed, at which point the MDC will execute an F-STOP.

- Operative from STOP mode only.
- R-STOP (TBB-9) and F-STOP (TBB-10) must be held low or tied to common (TBB-3).
- MDC must be in the Indication Display or User Setpoint Module.

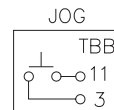

OPEN LOOP (TBB12): A maintained closure to common on this input causes the MDC to run open loop. The error correction value, Trim, is set to zero and speed is not regulated. A momentary closure on this input can be used as a Trim reset, to momentarily reset the Trim value to zero.

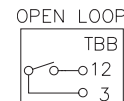

USER INPUTS 1 to 4 (TBB4 to 7): The User Input terminals require a closure to common to execute a programmable function. The action required may be maintained or momentary depending upon the function. The functions available are: View Display, Change Display, Reset Alarm, Setpoint Select, Ramp Select, Ramp Override, Increment Setpoint, Decrement Setpoint, and Program Disable. For a complete description of these functions, see the Program User Menu.

ALARM OUTPUTS 1 AND 2

The alarm outputs are open collector solid state outputs. They are programmable for High Alarm, Low Alarm, Deviation Alarm and Zero Speed Alarm functions. For details, see the Program Alarms Menu and the Block Diagram.

DRIVE ENABLE OUTPUT

The Drive Enable Output (TBA #7) provides an open collector closure to common whenever the MDC is in a RUN or JOG mode. It is inactive (open) only when the MDC is in STOP mode. This output may be used to control a relay which removes power from the motor and drive in STOP mode (see Block Diagram for details).

ISOLATED DRIVE OUTPUT

Before connecting the MDC to the motor drive, refer to the Isolated Drive Output Calibration section to determine if the MDC's analog drive output needs calibration. Most applications require calibration of the motor drive only.

The MDC can be operated with an internal or external voltage reference. The jumper above the bottom rear terminal block selects the internal reference when in the position closest to the board edge. The unit is shipped in this configuration. The internal reference is factory calibrated to provide 10.0 VDC full scale output. If your drive requires an input signal other than 0 to 10 VDC, refer to the section, Calibrating the Isolated Drive Output. If your drive does not have a process control input, the MDC may be wired to the drive in place of the drive's external speed potentiometer. In this case, set the jumper in the EXTERNAL position. The full scale output voltage is the "high" side of the drive's external potentiometer connection.

Wiring the MDC to the motor drive:

INTERNAL REFERENCE

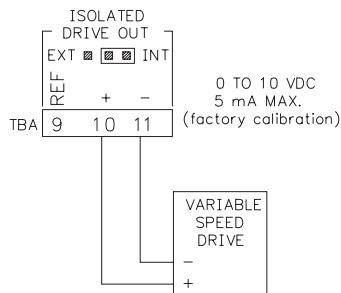

MDC wired to process control input on the variable speed drive. Reference voltage supplied by the MDC.

EXTERNAL REFERENCE

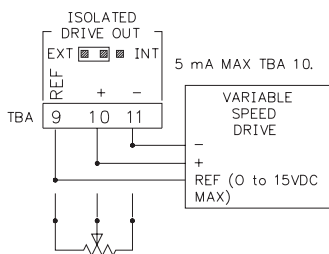

MDC wired in place of an external speed pot. The "Top of Pot" reference voltage is supplied from the variable speed drive. (*External speed pot must be removed.*) A register of equal value to the external pot may be needed across pins 9 and 11 of the MDC to stabilize the voltage level from the drive.

DIP SWITCH SET-UP

The DIP switches are accessible through the side of the MDC. The DIP switch positions and their functions are shown below:

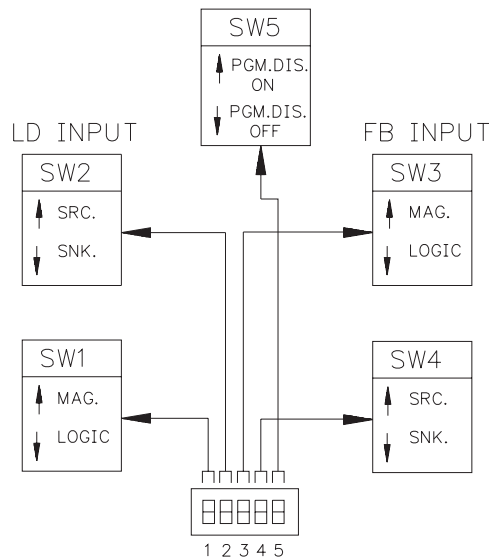

VARIOUS SENSOR OUTPUT CONNECTIONS (See Note 1)

<p>FREQUENCY SOURCE W/ISOLATED TRANSISTOR OUTPUTS CURRENT SOURCE CONNECTED CURRENT SINK CONNECTED</p> <p>AC PWRL +12VDC COMM.</p> <p>LEAD INP FEEDBACK COMM.</p> <p>MAG. SRC.</p> <p>LOGIC SNK.</p> <p>1 2 3 4</p> <p>1 2 3 4</p> <p>SEE NOTE 3 FOR INPUT VOLTAGES GREATER THAN +12V.</p> <p>RLC SENSOR MODELS: PR & RR PHOTO-ELECTRICS</p>	<p>OLDER STYLE SENSORS WITH -EF OUTPUT-CURRENT SRC CONN.</p> <p>AC PWRL +12VDC COMM.</p> <p>LEAD INP FEEDBACK COMM.</p> <p>MAG. SRC.</p> <p>LOGIC SNK.</p> <p>1 2 3 4</p> <p>1 2 3 4</p> <p>SENSOR WITH +5V EMITTER FOLLOWER OUTPUT</p> <p>RLC SENSOR MODELS: LMP-EC</p>	<p>SENSORS WITH CURRENT SINK OPEN COLLECTOR (NPN O.C.)</p> <p>AC PWRL +12VDC COMM.</p> <p>LEAD INP FEEDBACK COMM.</p> <p>MAG. SRC.</p> <p>LOGIC SNK.</p> <p>1 2 3 4</p> <p>1 2 3 4</p> <p>SENSOR WITH NPN O.C.</p> <p>C-WHT A-RED B-BLK</p> <p>SHIELD SEE NOTE 3</p> <p>RLC SENSOR MODELS: ASTC, LMPC, LSC, PSAC, RRGB, RPGC, RPGH</p>	<p>SENSORS WITH CURRENT SOURCE OUTPUT (PNP O.C.)</p> <p>AC PWRL +12VDC COMM.</p> <p>LEAD INP FEEDBACK COMM.</p> <p>MAG. SRC.</p> <p>LOGIC SNK.</p> <p>1 2 3 4</p> <p>1 2 3 4</p> <p>SENSOR</p>	
<p>2-WIRE PROXIMITY SENSORS CURRENT SOURCE CONNECTED</p> <p>AC PWRL +12VDC COMM.</p> <p>LEAD INP FEEDBACK COMM.</p> <p>MAG. SRC.</p> <p>LOGIC SNK.</p> <p>1 2 3 4</p> <p>1 2 3 4</p> <p>RLC SENSOR MODELS: PSA-1, PSA-2</p> <p>BLUE BLK OR BRN</p>	<p>MAGNETIC PICKUPS</p> <p>AC PWRL +12VDC COMM.</p> <p>LEAD INP FEEDBACK COMM.</p> <p>MAG. SRC.</p> <p>LOGIC SNK.</p> <p>1 2 3 4</p> <p>1 2 3 4</p> <p>MAGNETIC PICKUP</p> <p>SHIELD SEE NOTE 2</p>	<p>A.C. INPUTS FROM INVERTERS, TACH. GENERATORS, ETC.</p> <p>AC PWRL +12VDC COMM.</p> <p>LEAD INP FEEDBACK COMM.</p> <p>MAG. SRC.</p> <p>LOGIC SNK.</p> <p>1 2 3 4</p> <p>1 2 3 4</p> <p>A.C. SIGNAL</p> <p>RESISTOR TO LIMIT CURRENT TO 2.5mA MAXIMUM</p> <p>A.C. SIGNALS OVER 50 VAC PEAK SHOULD BE ISOLATED BY A STEP DOWN TRANSFORMER.</p>	<p>INTERFACING WITH CMOS CIRCUITRY (B TYPE)</p> <p>AC PWRL +12VDC COMM.</p> <p>LEAD INP FEEDBACK COMM.</p> <p>MAG. SRC.</p> <p>LOGIC SNK.</p> <p>1 2 3 4</p> <p>1 2 3 4</p> <p>CMOS INVERTER</p>	<p>INTERFACING WITH TTL</p> <p>AC PWRL +12VDC COMM.</p> <p>LEAD INP FEEDBACK COMM.</p> <p>MAG. SRC.</p> <p>LOGIC SNK.</p> <p>1 2 3 4</p> <p>1 2 3 4</p> <p>TTL INVERTER</p> <p>CLAMP DIODE</p> <p>+5V</p> <p>NOTE: CIRCUIT SHOWN FOR STD. TTL OUTPUT. TTL CIRCUITS ARE AVAILABLE W/OPEN COLLECTOR OUTPUTS ELIMINATING NEED FOR DIODE CLAMP.</p>

NOTES:

1. SENSOR VOLTAGE AND CURRENT

The +12 VDC (out) terminal can supply voltage to a sensor within a $\pm 25\%$ variation, due to line and internal load variations. All RLC sensors will accommodate this variation.

2. When shielded cable is used, the shield should be connected to "COMM." at the unit and left disconnected at the sensor end.

3. The Lead and Feedback frequency inputs can accept source pulses from other circuits up to +28 V in amplitude. For voltages above +28 V, a limiting resistor and zener diode should be used to limit the voltage at the input.

ISOLATED DRIVE OUTPUT CALIBRATION

Note: There is no need to calibrate the Drive Output Span if an EXTERNAL reference is used or if the INTERNAL reference is used with the factory calibrated 0 to 10 V span. If this is the case, skip Drive Output Span Calibration and go to Motor Drive Setup.

DRIVE OUTPUT SPAN CALIBRATION

- 1) Make sure that the INTERNAL/EXTERNAL jumper above the bottom rear terminal block is in the INTERNAL position.
- 2) Before connecting the MDC to the DRIVE, you must set the Span POT for the Full scale control output required by the DRIVE. Connect a voltmeter to the MDC drive output terminals. Power up the MDC. Enter the Programming Module (see Programming General Description). In the PROGRAM DIAGNOSTICS Menu, select TEST DRIVE OUTPUT. Push the Up arrow until the %Output reads 100%. The meter should read 10 VDC. Adjust the Span POT for the desired Full scale value within the 5 to 15 VDC specified range of the MDC.

MOTOR DRIVE SETUP

- 1) Before connecting the MDC to the Motor Drive, set up the Drive according to the manufacturer's instructions.
- 2) Then set the Drive's :
 - a) Acceleration / Deceleration POTs to minimum time (maximum rate).
 - b) IR compensation to a minimum.
 - c) Maximum Speed to 110% of the maximum normal operating speed with an unloaded or lightly loaded motor.

This completes the steps necessary to calibrate the MDC for the Motor and Drive. To verify that calibration is correct and to test system operation, continue with VERIFYING SYSTEM OPERATION.

VERIFYING SYSTEM OPERATION

- 1) With the MDC connected to the Drive as noted in Installation and Connections, power up the MDC and enter the Programming Module.
- 2) Set up the scaling for the MDC in the Program Scaling Menu, if you have not already done so.
- 3) Power up the Motor and Drive. The motor should have no load or be only lightly loaded.
- 4) Enter the Program Diagnostics Menu and select TEST DRV OUT. Use the Up arrow key to select 100% output. The transducer feedback in Hz is shown on display line two. It should be:

$$\text{Feedback (Hz)} = \frac{1.1 \times \text{PPR FB} \times \text{MAX RPM FB}}{60}$$

This allows 10% headroom to maintain regulation under various motor load conditions. If the feedback frequency is not close to this value, adjust the DRIVE's GAIN or MAXIMUM SPEED POT accordingly. Use the Up and Down arrow key to test the drive/motor operation over the full speed range. Use the F2/STP key to stop the motor immediately. Use the ESC key to stop immediately and exit TEST DRV OUT.

- 5) Verification complete. Exit the PROGRAM MODULE.

TRIM

The Trim value can be displayed on one of the programmable displays (See Program Displays Menu). The Trim value is the number of D/A correction bits out of the available 4095 that are required to maintain the target speed. This value should not be more than 200 to 300 during normal operation with an UNLOADED motor. The Trim value will increase to compensate for an increase in motor load. If the Trim value is over 300, refer to the Drive Output Span Calibration and Motor Drive Set-up sections above.

SPECIFICATIONS & DIMENSIONS

- DISPLAY:** 2x8, 0.3" (7 mm) high characters, negative image transmissive LCD, with red LED backlighting.
- POWER:** Switch selectable for:
115 VAC $\pm 10\%$, 50/60 Hz, 10 VA or
230 VAC $\pm 10\%$, 50/60 Hz, 10 VA.
- MEMORY:** Non-volatile E²Prom retains all programming information and values when power is removed or interrupted.
Power Cycles (ON/OFF): 100,000 minimum.
Data Retention: 10 years minimum.
- SENSOR POWER:** +12 VDC $\pm 25\%$ @ 100 mA.
- INPUTS (LEAD AND FEEDBACK):** DIP Switch selectable to accept input pulses from a variety of sources including outputs from CMOS or TTL circuits and all standard RLC sensors.
Input Freq: 1 Hz to 20 KHz (Master Mode),
1 Hz to 12 KHz (Follower Mode).
LOGIC: Input trigger levels $V_{IL} = 1.5 V_{MAX}$; $V_{IH} = 3.75 V_{MIN}$.
Current Sinking: Internal 7.8 K Ω pull up to +12 VDC, $I_{MAX} = 1.6$ mA.
Current Sourcing: Internal 3.9 K Ω pull-down, 7.3 mA @ 28 VDC_{MAX}.

MAGNETIC PICKUP:

Sensitivity: 200 mV PEAK.

Hysteresis: 100 mV.

Input impedance: 3.9 K Ω @ 60 Hz.

Maximum input voltage: ± 50 V PEAK.

Note: For magnetic pickup input, the Sink/Source DIP switch must be in the SRC position.

6. CONTROL LOOP RESPONSE:

10 msec (Master Mode), 20 msec (Follower Mode).

7. CONTROL ACCURACY:

0.01% of Speed Setpoint (Master Mode)

0.02% of Ratio Setpoint (Follower Mode)

Minimum Frequency Resolution: 0.00125 Hz

8. ERROR TRIM: ± 4095 BITS.

9. ERROR GAIN: 0 to 99%.

10. RAMP RATE: (RAMP 1, RAMP 2, AND JOG RAMP)

1 Hz to 20 KHz/sec, set in user units/sec.

0.0001 to 1.9999 ratio units/sec (Ramp 1 & 2 in Follower Mode).

DIMENSIONS In inches (mm)

Note: Recommended minimum clearance (behind the panel) for mounting clip installation is 3.0" (76.2) H x 4.0" (101.6) W.

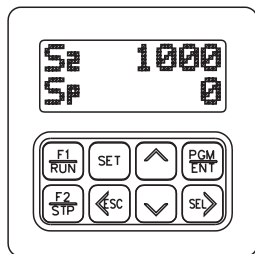

2.95 (74.9)

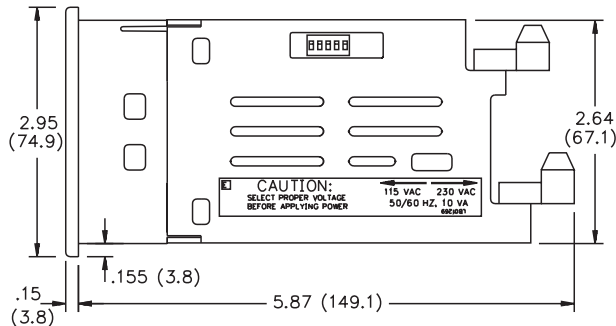

PANEL CUT-OUT

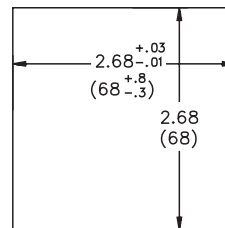

11. CONTROL INPUTS:

Internal 10 K Ω pull-up to +5 VDC. $V_{IL} = 1.0 V_{MAX}$. $V_{IH} = 4.0 V_{MIN}$.
Response time = 10 msec nominal, 30 msec maximum.

<u>INPUTS</u>	<u>SWITCH CONNECTIONS</u>
RUN	Momentary N.O.
FAST STOP	Momentary N.C.
RAMP STOP	Momentary N.C.
JOG	Sustained N.O.
OPEN LOOP	Maintained
USER INPUTS (4)	Function Specific

12. OUTPUTS:

DRIVE ENABLE, ALARM 1, and ALARM 2:

Solid state, current sinking NPN Open collector transistor.

$V_{CE} = 1.1 V_{SAT}$ @ 100 mA maximum, $V_{OH} = 30$ VDC maximum.
(Internal zener diode protection.)

Response Time:

Drive Enable: 10 msec nominal; 30 msec maximum.

ALARM 1&2: Programmable

NORMAL: 1 sec nominal, 2 sec maximum.

FAST: 20 msec nominal, 40 msec maximum.

ISOLATED DRIVE OUTPUT: Jumper selectable internal/external
reference 5 mA MAX.

Internal Reference: Pot adjustable from 0 to 5 VDC minimum span
through 0 to 15 VDC maximum span.

External Reference: 15 VDC maximum. (positive polarity only).

ISOLATION: 2300 Vrms for 1 minute
250 V working

13. ENVIRONMENTAL CONDITIONS:

Operating Temperature: 0° to 50°C

Storage Temperature: -40° to 70°C.

Operating And Storage Humidity: 85% max. relative humidity
(non-condensing) from 0°C to 50°C

Altitude: Up to 2000 meters

14. CERTIFICATIONS AND COMPLIANCES: ELECTROMAGNETIC COMPATIBILITY

Immunity to EN 50082-2

Electrostatic discharge	EN 61000-4-2	Level 2; 4 Kv contact Level 3; 8 Kv air
Electromagnetic RF fields	EN 61000-4-3	Level 3; 10 V/m 80 MHz - 1 GHz
Fast transients (burst)	EN 61000-4-4	Level 4; 2 Kv I/O Level 3; 2 Kv power
RF conducted interference	EN 61000-4-6	Level 3; 10 V/ms 150KHz - 80 MHz
Power frequency magnetic fields	EN 61000-4-8	Level 4; 30 A/m
Simulation of cordless telephone	ENV 50204	Level 3; 10 V/m 900 MHz \pm 5MHz 200 Hz, 50% duty cycle

Emissions to EN 50081-2

RF interference	EN 55011	Enclosure class A Power mains class A
-----------------	----------	--

Note: Refer to the EMC Installation Guidelines for additional information.

15. **CONSTRUCTION:** High impact plastic case with clear viewing window. The front panel meets NEMA 4X/IP65 requirements for indoor use when properly installed. Panel gasket and mounting clips included. Installation Category II, Pollution Degree 2.

16. **WEIGHT:** 1.5 lbs. (0.68 Kg).

TROUBLESHOOTING GUIDE

Use the Program Diagnostics Menu in the MDC to functionally test the system hardware. Each input and output can be tested independently. The following list may also help localize the problem.

For further technical assistance, contact technical support at the numbers listed on the back cover of the instruction manual.

PROBLEMS	POSSIBLE CAUSE	REMEDIES
NO DISPLAY	<ol style="list-style-type: none"> 1. Power off 2. Improperly wired 3. Voltage selector switch in the wrong position. 4. Power in a Brown out condition. 	<ol style="list-style-type: none"> 1. Verify power. 2. Check Wiring. 3. Check switch position. 4. Verify supply voltage.
CHECK SUM ERROR 1 OR 2 ON DISPLAY	<ol style="list-style-type: none"> 1. Data error detected by processor. 2. Power turned off with the unit in the Programming Module (after entering new data values). 	<ol style="list-style-type: none"> 1. Press “ENT” then “SEL”. <ol style="list-style-type: none"> a. Check all programming parameters. b. Check signal lines for possible noise sources. 2. Press “ENT” then “SEL” <ol style="list-style-type: none"> a. Reenter new values.
CANNOT ENTER PROGRAMMING MENUS	<ol style="list-style-type: none"> 1. Front panel disabled. 2. Wrong pro code number. 3. Unit in JOG mode. 	<ol style="list-style-type: none"> 1. Check Front Panel Accessible Programming With Program Disable section of the manual. 2. Enter correct number, (factory default is 0) or see section above. 3. Place unit in STOP mode.
UNIT WILL NOT ACCEPT THE DESIRED USER SETPOINTS	<ol style="list-style-type: none"> 1. User setpoint is out of range. 	<ol style="list-style-type: none"> 1. Check the limits listed in the User Setpoints section of the manual.
SETPOINT CAN BE VIEWED BUT NOT CHANGED	<ol style="list-style-type: none"> 1. Front panel disabled. 	<ol style="list-style-type: none"> 1. Verify programming in Program Options Menu Operator Access section. <ol style="list-style-type: none"> a. Check Front Panel Accessible Programming with Program Disable section of the manual.
UNIT WILL NOT ENTER RUN MODE	<ol style="list-style-type: none"> 1. R-STOP, F-STOP inputs wired incorrectly. 2. Unit in Program mode. 3. Unit is in JOG mode. 	<ol style="list-style-type: none"> 1. R-STOP and F-STOP inputs must be held low or tied to comm. to enter RUN mode. 2. RUN is disabled. Exit the programming module. 3. Place unit in STOP mode.

TROUBLESHOOTING GUIDE (Cont'd)

PROBLEMS	POSSIBLE CAUSE	REMEDIES
UNIT WILL NOT ENTER JOG MODE	<ol style="list-style-type: none"> 1. R-STOP, F-STOP inputs wired incorrectly. 2. Unit in Program mode. 3. Unit is in RUN mode. 	<ol style="list-style-type: none"> 1. R-STOP and F-STOP inputs must be held low or tied to comm. to enter JOG mode. 2. JOG is disabled. Exit the programming module. 3. Place unit in STOP mode.
UNIT INDICATES ZERO SPEED (MOTOR RUNNING)	<ol style="list-style-type: none"> 1. No feedback signal. 2. Type of input signal incorrectly selected. 3. Scaling parameters programmed incorrectly. PPR, MAX RPM too large or DSP UNIT too small. 	<ol style="list-style-type: none"> 1. Check sensor connection. Verify power to sensor. 2. Check DIP switch setting on side of unit. 3. Check parameters in Program Scaling Menu. Verify correct FB freq. in Program Diagnostics Menu TEST DRV OUT.
MOTOR WILL NOT RUN WITH MDC IN "RUN" MODE	<ol style="list-style-type: none"> 1. Motor or Drive problem. 2. Internal/External jumper for Drive Output in wrong position. 3. MDC Isolated Drive Output improperly calibrated. 4. Speed or Ratio setpoint zero or too low. 5. In Follower mode and Lead input is zero. 	<ol style="list-style-type: none"> 1. Make sure motor and drive operate independent of MDC. 2. Refer to Installation and Connections section of manual. 3. See Isolated Drive Output Calibration section of manual. Verify operation using Program Diagnostics Menu TEST DRV OUT. 4. Check speed/ratio Setpoint 1 and 2. 5. Verify by programming a DISPLAY for Lead frequency.
"NO FEEDBACK" MESSAGE DISPLAYED/UNIT ENTERS STOP MODE	<ol style="list-style-type: none"> 1. No feedback signal present. 2. Drive improperly calibrated. 3. MDC Isolated Drive Output improperly calibrated. 4. Large "dead band" in drive and motor response at low speed. 	<ol style="list-style-type: none"> 1. Check sensor connection. Verify power to sensor. 2. See drive manual. 3. See Isolated Drive Output Calibration section of manual. 4. Disable Feedback Loss Detection in the Program Options Menu.

TROUBLESHOOTING GUIDE (Cont'd)

PROBLEMS	POSSIBLE CAUSE	REMEDIES
UNIT DOES NOT INDICATE SPEED CORRECTLY	<ol style="list-style-type: none"> 1. Type of input signal incorrectly selected. 2. Feedback input improperly connected. 3. Electrical noise interference. 4. Scaling parameters programmed incorrectly. (PPR, MAX RPM, DSP UNIT) 	<ol style="list-style-type: none"> 1. Check DIP switch set-up on side of unit. 2. Check sensor connection. 3. Check power source for noise. Check signal wire routing. 4. Check parameters in Program Scaling Menu. Verify correct FB freq. in Program Diagnostics Menu TEST DRV OUT.
UNIT DOES NOT REGULATE SPEED	<ol style="list-style-type: none"> 1. Error GAIN is zero. 2. Open loop input held low. Unit in open loop mode. 	<ol style="list-style-type: none"> 1. Check GAIN setting in User Setpoints Module. 2. Check Open Loop input. It should be open (not connected to common) for closed loop operation.
USER INPUT DOES NOT ACTIVATE THE DESIRED FUNCTION	<ol style="list-style-type: none"> 1. User input NOT properly programmed. 2. User input improperly connected. 	<ol style="list-style-type: none"> 1. Verify programming in Program User Menu. 2. Verify connections using Program Diagnostic Menu READ USR.
UNIT OVERSHOOTS SPEED SETPOINT	<ol style="list-style-type: none"> 1. Error GAIN too high. 	<ol style="list-style-type: none"> 1. Reduce GAIN setpoint.
UNIT RESPONDS SLOWLY TO LOAD CHANGES	<ol style="list-style-type: none"> 1. Error GAIN too low. 	<ol style="list-style-type: none"> 1. Increase GAIN setpoint.
UNIT RAMP RATE IS NON-LINEAR/ LARGE "TRIM" VALUES	<ol style="list-style-type: none"> 1. Motor drive improperly calibrated. 2. MDC Isolated Drive Output improperly calibrated. 	<ol style="list-style-type: none"> 1. See motor drive manufacturer's manual. 2. See Isolated Drive Output Calibration section of manual.
UNIT DISPLAYS AN OVERFLOW MESSAGE	<ol style="list-style-type: none"> 1. Value out of range. 	<ol style="list-style-type: none"> 1. See Overflow Indication section of manual.
ALARM OUTPUT WILL NOT RESET FROM USER INPUT	<ol style="list-style-type: none"> 1. User Input NOT properly programmed. 2. Momentary closure on User Input while condition causing the alarm. 	<ol style="list-style-type: none"> 1. Verify programming in Program User Menu. 2. Provide a maintained closure or remove causing alarm is still present.

APPENDIX "A" APPLICATIONS

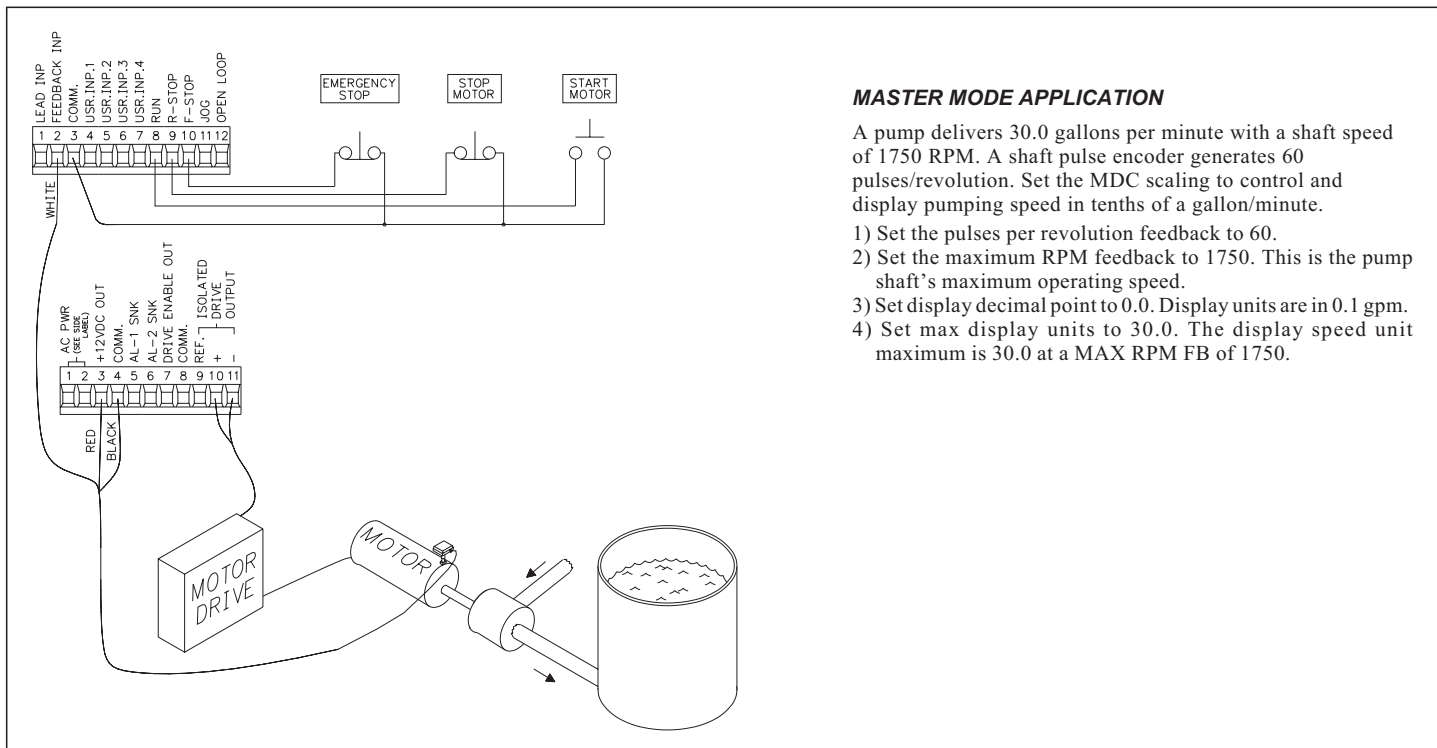

FOLLOWER MODE APPLICATION

A fertilizer production facility is mixing pellets containing Nitrogen with pellets that contain Phosphorus. A chemical ratio of 1:1 is determined by the speed of two different conveyors. Because of differences in the gearing of the conveyor and concentration of the pellets, the Nitrogen conveyor motor must run at 3 times the speed of the Phosphorus conveyor motor in order to produce a 1:1 mix. The maximum speed of both motors is 2000 RPM. Set the follower MDC scaling to produce a 1:1 mix of Nitrogen and Phosphorus when a setpoint of 1.0000 is entered. Display speed units are in RPM's. Both the lead and feedback frequency are taken from 60 tooth gears on each motor shaft.

- 1) Choose the Phosphorus conveyor motor for the follower MDC. It runs slower than the Nitrogen conveyor motor.
- 2) Set the Pulses per revolution feedback to 60.
- 3) Set the MAX RPM feedback to 2000. This is the conveyor motor's maximum operating speed.
- 4) Set display decimal point to 0.
- 5) Set display unit to 2000. The display speed unit maximum is 2000 at a MAX RPM FB of 2000. If the display units wanted were conveyor feet/minute or Phosphorus pellets in lbs/sec, the equivalent display value for 2000 RPM would be entered.
- 6) Set the pulses per revolution lead to 60.
- 7) Setting the MAX RPM Lead:

This is the Lead RPM that would be necessary to have a 1:1 mixture if the Follower Speed was MAX RPM FB (2000 RPM). Since the Nitrogen conveyor motor must run 3 times as fast as the Phosphorus motor, $\text{MAX RPM LD} = 3 \times 2000 = 6000 \text{ RPM}$. Set $\text{MAX RPM LD} = 6000 \text{ RPM}$. This is the correct value, even though the Nitrogen conveyor motor would never actually run at 6000 RPM. A ratio setpoint of 1.0000 on the MDC is now equal to a 1:1 mixture of Phosphorus and Nitrogen.

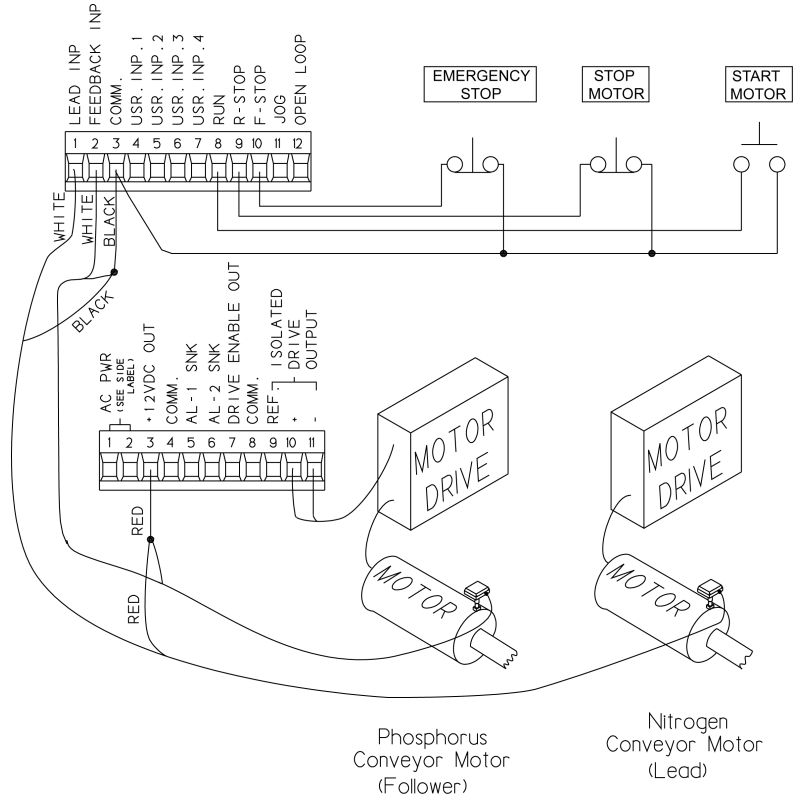

APPENDIX “B” - ORDERING INFORMATION

MODEL NO.	DESCRIPTION	PART NUMBER 115/230 VAC
MDC	Motor Drive Controller	MDC00100
For information on Pricing, refer to the RLC catalog or contact your local RLC distributor.		

LIMITED WARRANTY

The Company warrants the products it manufactures against defects in materials and workmanship for a period limited to one year from the date of shipment, provided the products have been stored, handled, installed, and used under proper conditions. The Company's liability under this limited warranty shall extend only to the repair or replacement of a defective product, at The Company's option. The Company disclaims all liability for any affirmation, promise or representation with respect to the products.

The customer agrees to hold Red Lion Controls harmless from, defend, and indemnify RLC against damages, claims, and expenses arising out of subsequent sales of RLC products or products containing components manufactured by RLC and based upon personal injuries, deaths, property damage, lost profits, and other matters which Buyer, its employees, or sub-contractors are or may be to any extent liable, including without limitation penalties imposed by the Consumer Product Safety Act (P.L. 92-573) and liability imposed upon any person pursuant to the Magnuson-Moss Warranty Act (P.L. 93-637), as now in effect or as amended hereafter.

No warranties expressed or implied are created with respect to The Company's products except those expressly contained herein. The Customer acknowledges the disclaimers and limitations contained and relies on no other warranties or affirmations.

Red Lion Controls
20 Willow Springs Circle
York PA 17402
Tel +1 (717) 767-6511
Fax +1 (717) 764-0839

Red Lion Controls BV
Basicweg 11b
NL - 3821 BR Amersfoort
Tel +31 (0) 334 723 225
Fax +31 (0) 334 893 793

Red Lion Controls AP
31, Kaki Bukit Road 3,
#06-04/05 TechLink
Singapore 417818
Tel +65 6744-6613
Fax +65 6743-3360