

HD D-sub 78P MALE CONNECTOR

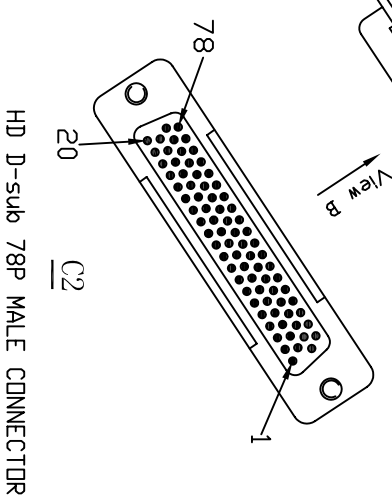
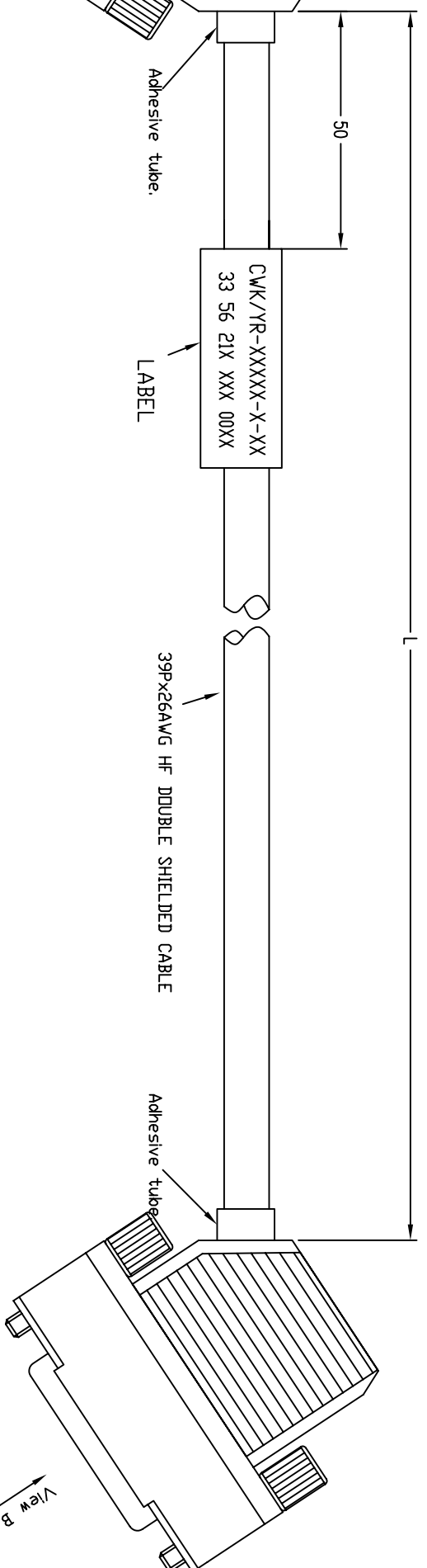

HD D-sub 78P MALE CONNECTOR

WIRING TABLE

PAIR NO	C1	C2	PAIR NO	C1	C2	PAIR NO	C1	C2
1	1	1	14	27	27	27	53	53
2	2	2	15	28	28	28	54	54
3	3	3	16	29	29	29	55	55
4	4	4	17	30	30	30	56	56
5	5	5	18	31	31	31	57	57
6	6	6	19	32	32	32	58	58
7	7	7	20	33	33	33	59	59
8	8	8	21	34	34	34	60	60
9	9	9	22	35	35	35	61	61
10	10	10	23	36	36	36	62	62
11	11	11	24	37	37	37	63	63
12	12	12	25	38	38	38	64	64
13	13	13	26	39	39	39	65	65
14	14	14		40	40	40	66	66
15	15	15		41	41	41	67	67
16	16	16		42	42	42	68	68
17	17	17		43	43	43	69	69
18	18	18		44	44	44	70	70
19	19	19		45	45	45	71	71
20	20	20		46	46	46	72	72
21	21	21		47	47	47	73	73
22	22	22		48	48	48	74	74
23	23	23		49	49	49	75	75
24	24	24		50	50	50	76	76
25	25	25		51	51	51	77	77
26	26	26		52	52	52	78	78
							Shell	Shell

Part-No.	Dim.L
33 56 212 200 0031	20 m
33 56 212 100 0030	10 m
33 56 212 050 0029	5 m
33 56 213 200 0016	2 m
33 56 213 100 0002	1 m
33 56 212 005 0028	0.5 m

- NOTES:
- 1.) CABLE MUST BE PERFORMED CONTINUITY TEST AND HI-POT TEST.
 - 2.) OPERATING TEMPERATURE = 0°TD +80°C
 - 3.) WHITE LABEL CONTENT:

DATE CODE & LOT INFORMATION
HARTING P/N

- 4.) THE CABLE SHOULD BE PACKED BY A PLASTIC BAG AND STICK THE LABEL WITH P/N CONTENT ON IT, THEN PUT IT INTO THE CARTON THE QTY ACCORDING TO ACTUAL CONDITION.
- 5.) EXPORT CARTON SHOULD BE STICKED THE LABEL WITH P/N AND QTY CONTENT.

All Dimensions in mm Original Size DIN A 3		Techn. Character.		Free size tolerances	
Mod.	Da.t.	Part-No.	Dim.L	Scale	Dim.L
		33 56 212 200 0031	20 m	1:1	±0.1
		33 56 212 100 0030	10 m	1:1	±0.1
		33 56 212 050 0029	5 m	1:1	±0.1
		33 56 213 200 0016	2 m	1:1	±0.1
		33 56 213 100 0002	1 m	1:1	±0.1
		33 56 212 005 0028	0.5 m	1:1	±0.1

Mod.	Da.t.	Name	Detail	Insp.	Stand.	Scale	Sub.
		ZHUHAI HARTING LIMITED	08/08/08	Andrew H		1:1	TB 33 56 0005.00

