

LOC		DIST		REVISIONS			
P	LTR	DESCRIPTION	DATE	DWN	APVD		
A		REVISED PER 0638-0283-03	01-MAY-03	KW	DC		

- PART MUST COMPLY WITH AMP SOLDERABILITY SPEC 109-11-5.
- RECOMMENDED EXPOSURE TO SOLDER WAVE 254 C (490 F) NOT TO EXCEED 5 SECONDS.
- DIMENSIONS IN BRACKETS ARE IN INCHES.

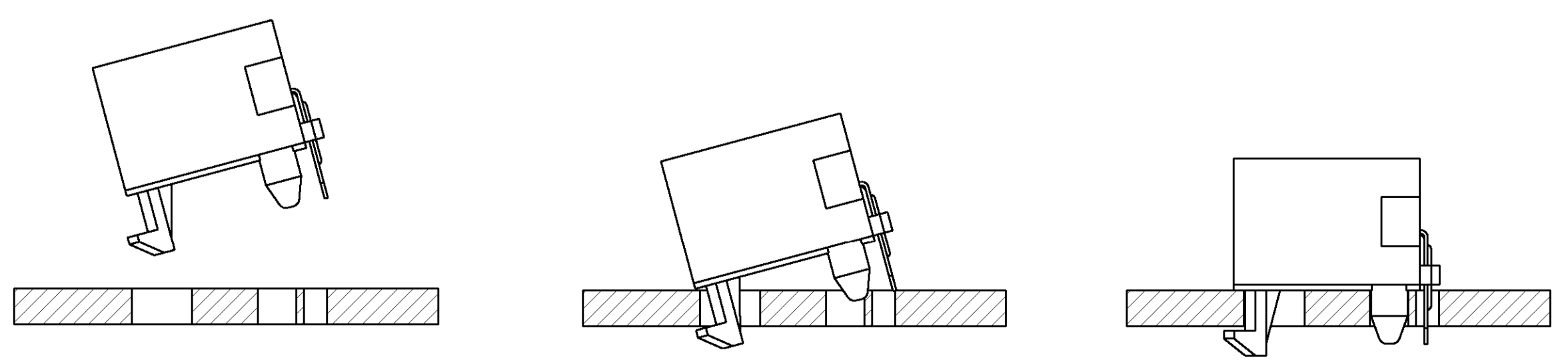
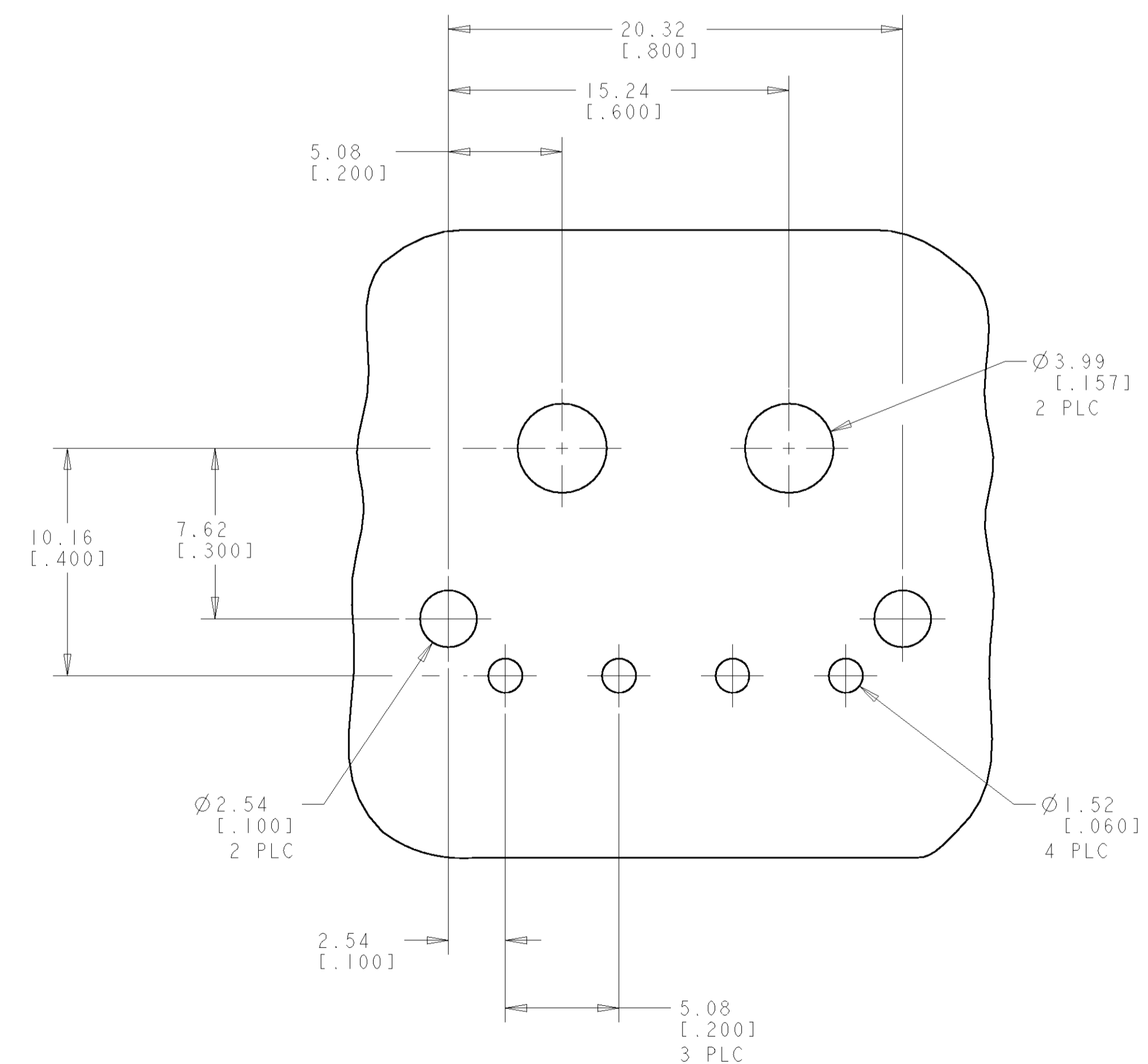
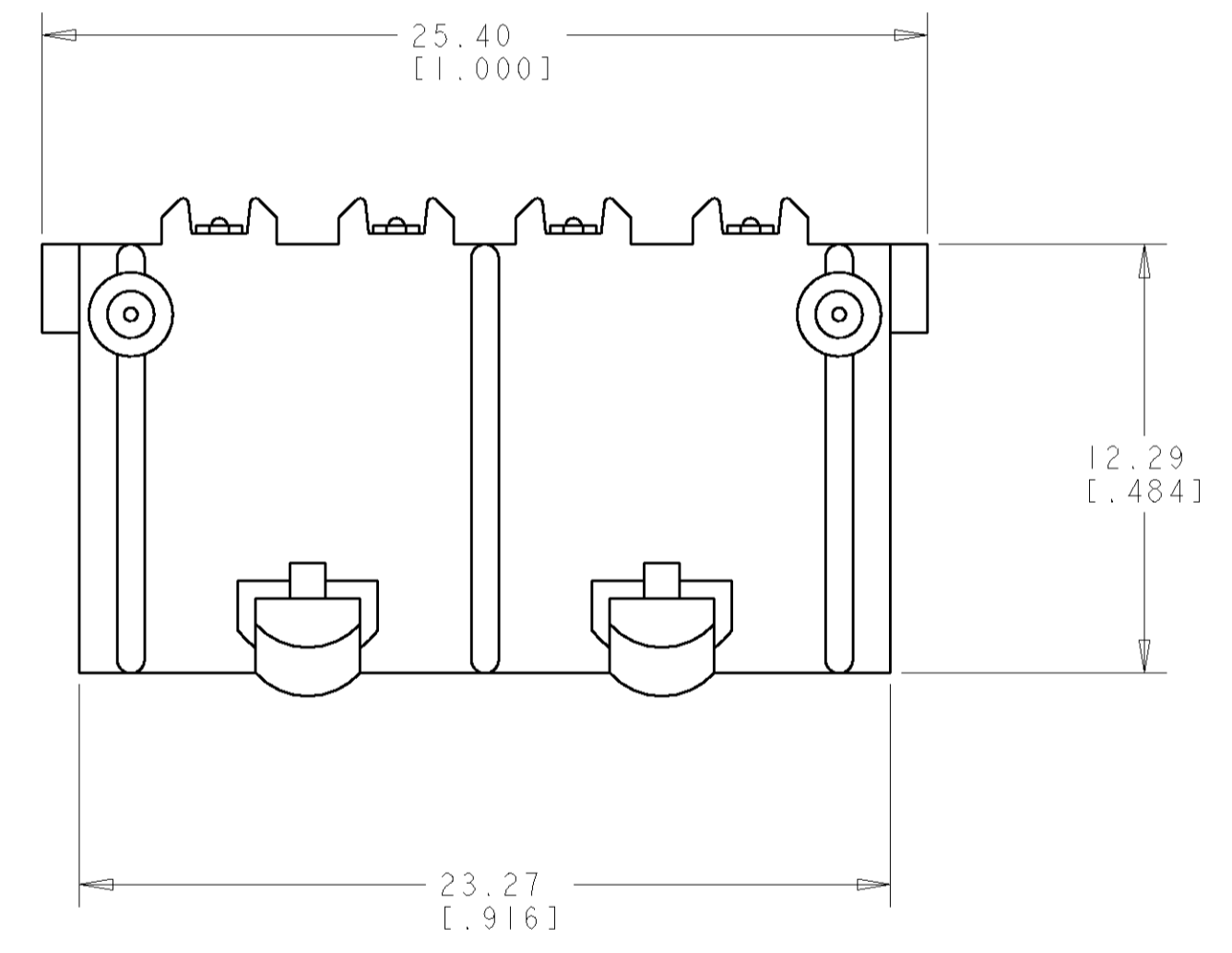
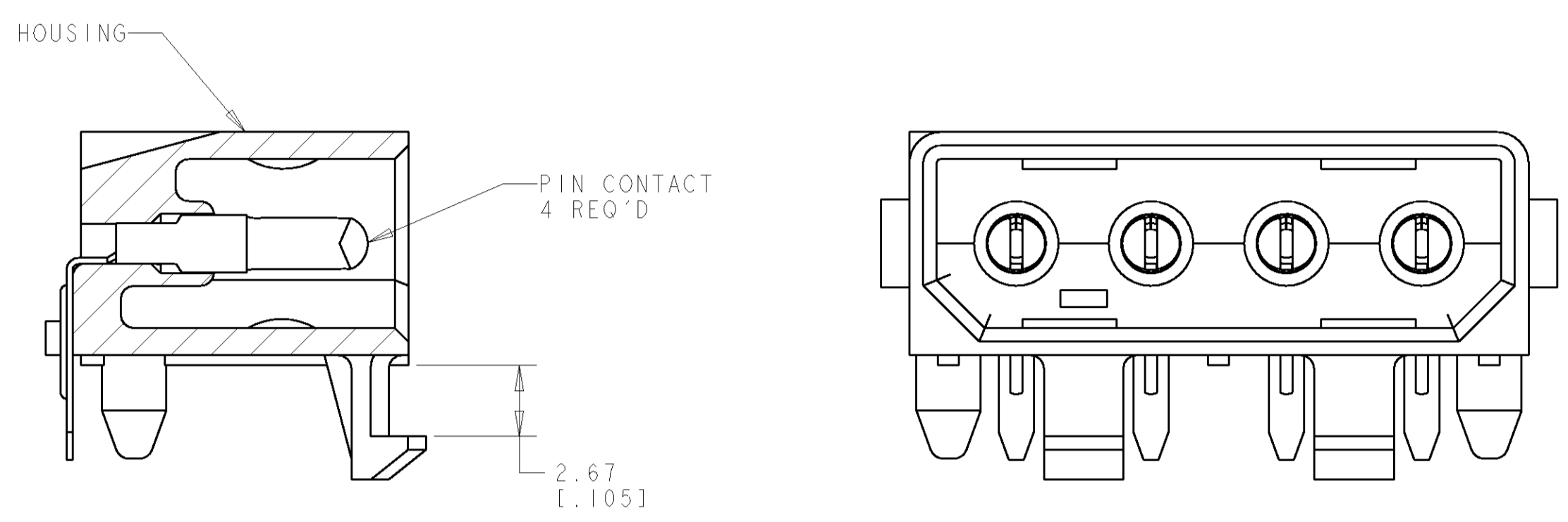
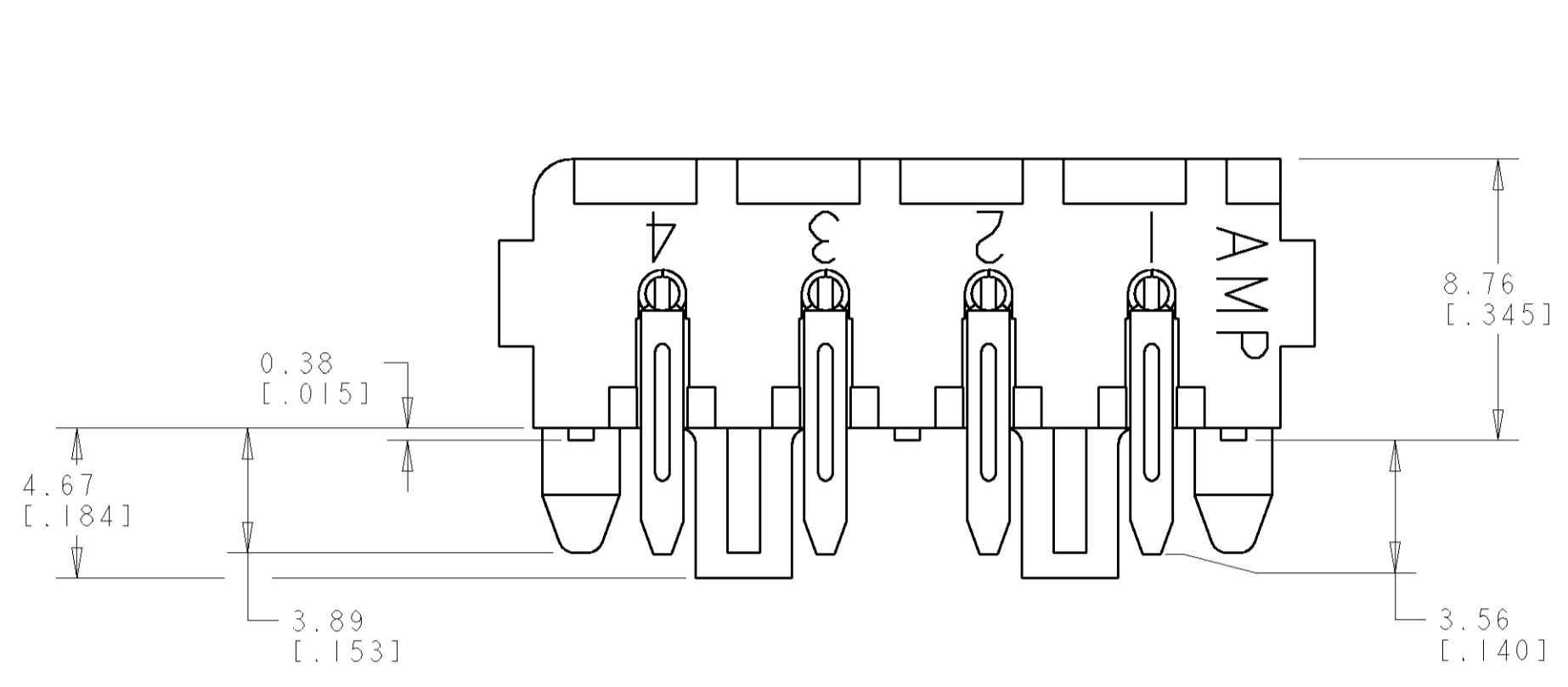

MOUNTING PROCEDURE

RECOMMENDED MOUNTING HOLE PATTERN FOR 2.36 [0.093] THICK P.C. BOARD

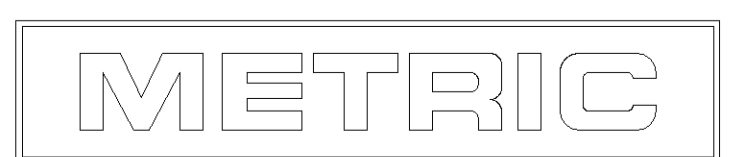

PIN		HOUSING			PART NO
PH BRZ	PRE-TIN	NYLON, 94V-2	NATURAL	794697-1	
MATERIAL	FINISH	MATERIAL	COLOR		
DIMENSIONS:		TOLERANCES UNLESS OTHERWISE SPECIFIED:		DWN: B. WHITAKER 01-MAY-2003	
mm [INCHES]		0 PLC ±		CHK: D. COLEY 01-MAY-2003	
1 PLC ±		2 PLC ±0.13 [0.005]		APVD: D. COLEY 01-MAY-2003	
3 PLC ±		4 PLC ±		PRODUCT SPEC	
4 PLC ±		ANGLES ±		APPLICATION SPEC	
FINISH		WEIGHT		SIZE: CAGE CODE DRAWING NO. RESTRICTED TO	
MATERIAL		CUSTOMER DRAWING		A 00779 C=794697	
SCALE 5:1		SHEET 1 OF 1		REV A	