

THIS DRAWING IS UNPUBLISHED. RELEASED FOR PUBLICATION  
 © COPYRIGHT - By - ALL RIGHTS RESERVED.

LOC		DIST		REVISIONS					
AF		50		P	LTR	DESCRIPTION	DATE	DWN	APVD
				A2		ECR-15-000371	09JAN15	PKS	RRP

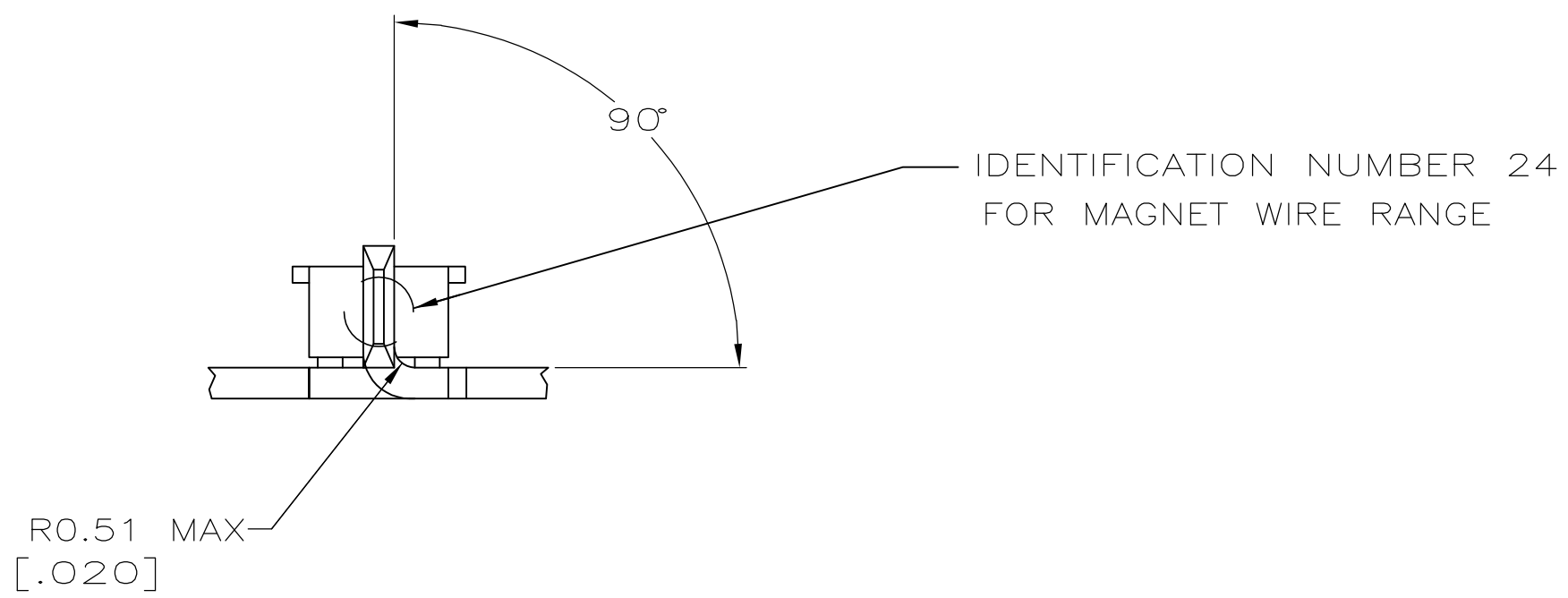

- 1 CONTINUOUS STRIP ON REELS WITH TERMINALS LOCATED ON 8.38±0.076 [.330±.003] CENTERS
- 2 SLOT ACCEPTS SINGLE OR DOUBLE 1.05-1.15mm DIA [#18-#17] AWG COPPER OR ALUMINUM MAGNET WIRE
- 3 REFER TO DWG 87-1039-3 FOR ADDITIONAL CAVITY INFORMATION (MODIFIED DEPTH)
- 4 ~~PRE-PRODUCTION FASR REQUIRED~~
- 5 0.0010 [.000040] MIN TIN PLATE

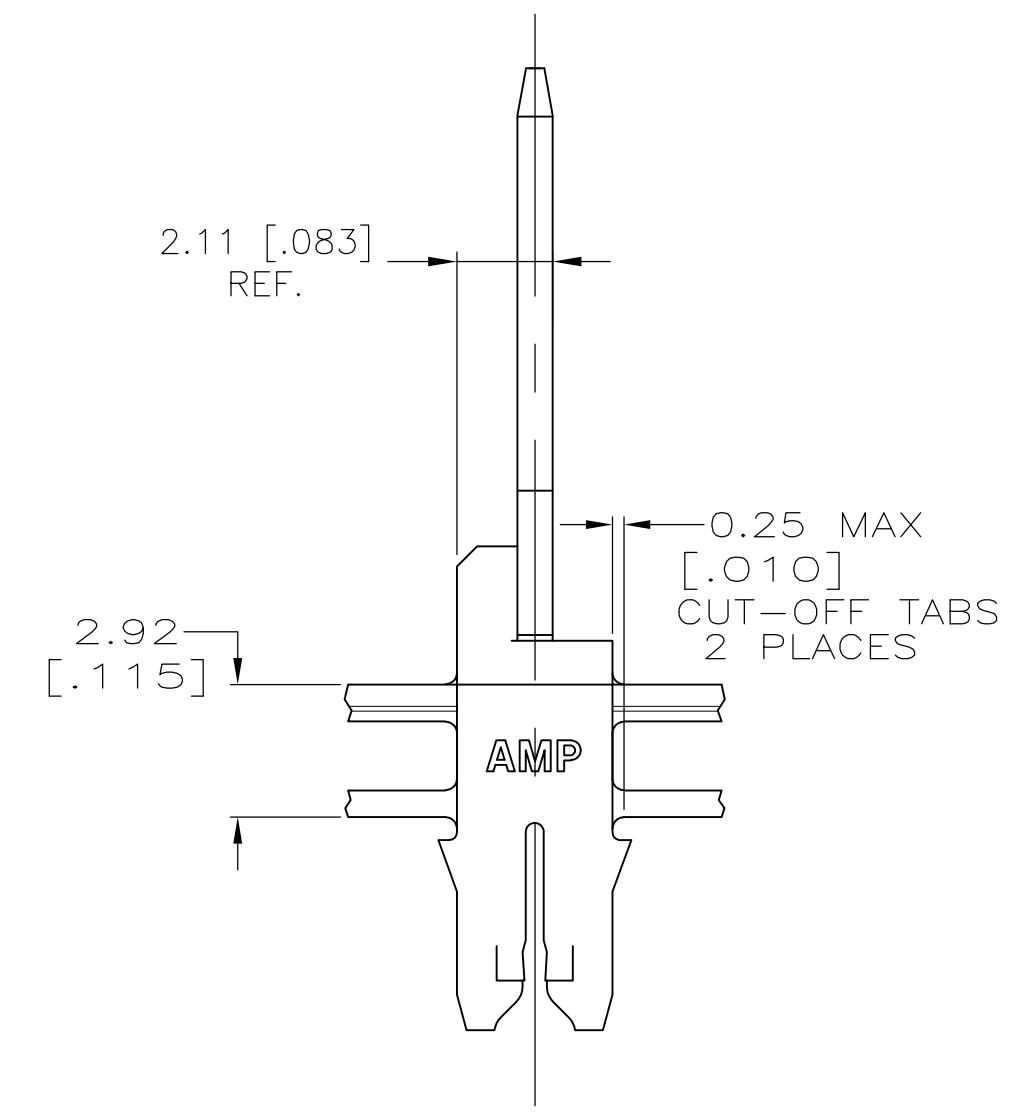
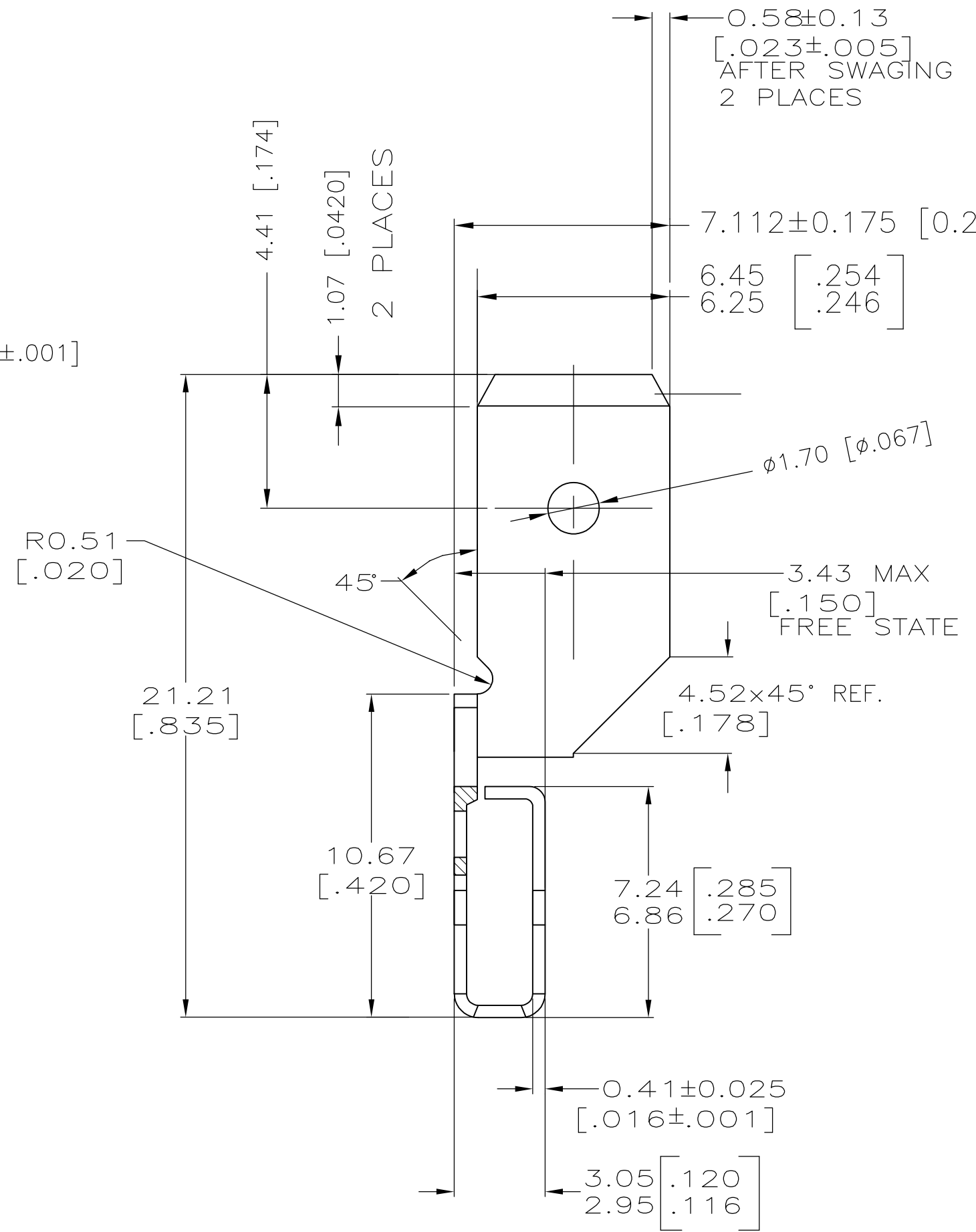
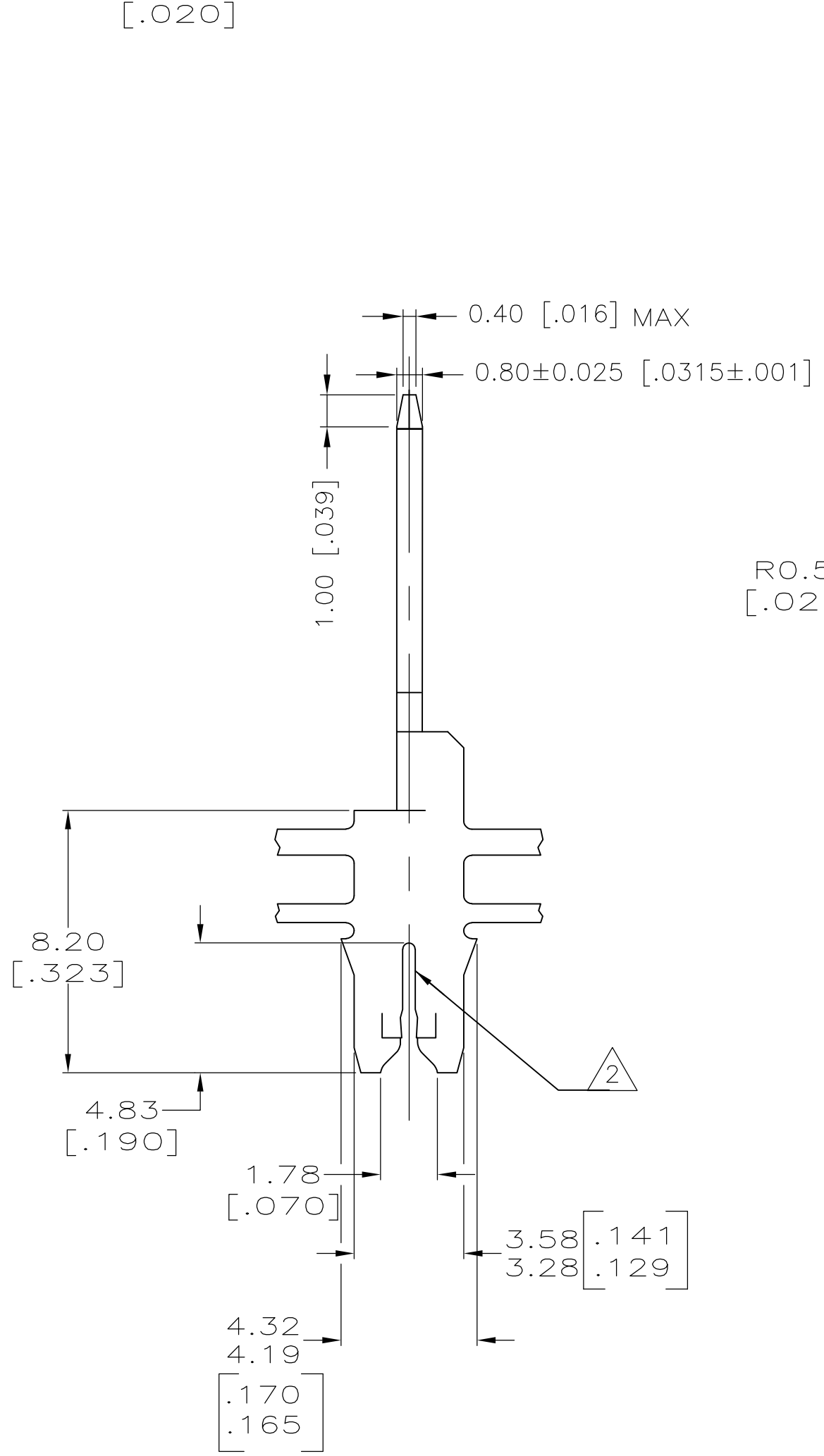

THIS DRAWING IS A CONTROLLED DOCUMENT.		DWN	R.GRZYBOWSKI	24JUN97	FINISH		WELD	2232556-1
DIMENSIONS: mm		CHK	M.S.FEHER	24JUN97	SPLICE		PART NUMBER	
TOLERANCES UNLESS OTHERWISE SPECIFIED:		APVD	N.E.NEFF	24JUN97	NAME		TE Connectivity	
0 PLC ± -	1 PLC ± -	PRODUCT SPEC	108-2012		TAB, 6.30 [.250] CONNECTING, MAG-MATE		-	
2 PLC ± 0.25 [.010]	3 PLC ± -	APPLICATION SPEC	114-2046		SIZE	A2	CAGE CODE	00779
4 PLC ± -	ANGLES ± 5°	FINISH	SEE TABLE		DRAWING NO	C=2232556		RESTRICTED TO
MATERIAL PRE-MILLED BRASS		WEIGHT	-		SCALE	6:1		SHEET 1 of 1
CUSTOMER DRAWING		REV		A2				