

PART NO.	ENG. NO.
02-09-1122	2273-A(P90 I)
02-09-1123	2273-A(P90 IL)
-	-
-	-
-	-
-	-
-	-
-	-

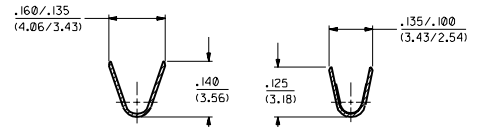

SECTION "A-A" **SECTION "B-B"**

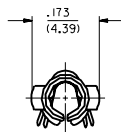
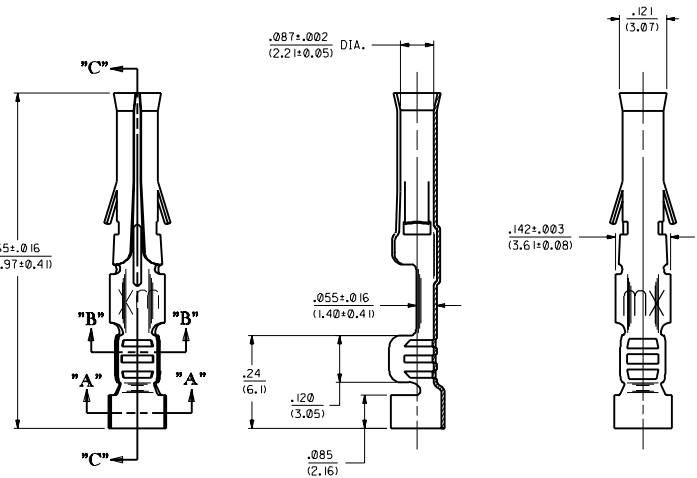

SECTION "C-C"

LEGEND
 2273-A(****)*
 * - FORM BLANK-CHAIN L-LOOSE
 ** - FINISH CODE
 P-PREPLATE BLANK-POSTPLATE

- NOTES:
1. TERMINAL FOR USE WITH .093/(2.36) SERIES HOUSINGS AND WILL ACCEPT 18 THRU 22 AWG WIRE.
 2. INSERTION FORCE: 2.0 LBS. AVG. WHEN TERMINAL IS INSERTED INTO AN .093 SERIES HOUSING.
 3. CONTACT RETENTION: 20 LBS. MIN.
 4. THIS PART CONFORMS TO PRODUCT SPEC. 02-09.

MATERIAL NOTES:
 1. CARTRIDGE BRASS, ALLOY #C26000
 .008/(0.20) THICK, SPRING TEMPER

FINISH CODES:
 901 HOT TIN DIP .000020/(0.0005) MIN.

CHAIN FORM
 FULL SCALE

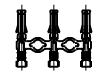

B	REVISE PER EGR US 0799 CJC 2/10/94	RW
A	FINAL RELEASE EGR US 0795 CJC 4/5/91	RW

DIMENSIONS SHOWN METRIC UNLESS NOTED OTHERWISE OTHERWISE UNLESS NOTED OTHERWISE		MFG. SH. REV. L.T.R. REVISIONS	
TITLE CRIMP TERM, FEMALE .093/(2.36) DIA. FOR 18 THRU 22 AWG WIRE		REVISE ONLY ON CAD SYSTEM	
PART NO. SD-2273-X1		DATE 10/14/5/91	
DRAWN BY CWF		CHECKED BY RW	
SCALE 6:1		MATERIAL SD-2273-X1	
APP'D. CWF		DATE 10/14/5/91	

2273