

THIS COPY IS PROVIDED ON A RESTRICTED BASIS AND IS NOT TO BE USED IN ANY WAY DETRIMENTAL TO THE INTERESTS OF PANDUIT CORP.

|             |                                   |
|-------------|-----------------------------------|
| PANDUIT P/N | WEIGHT                            |
| CFFPHM4**   | .44 LB/10 PCS<br>(201.2 g/10 PCS) |

NOTES:

- SEE CURRENT CATALOG FOR ADDITIONAL PART NUMBER SUFFIXES TO INDICATE COLOR AND OR PACKAGE QUANTITY.
- SEE CATALOG FOR COMPLETE LIST OF PARTS APPLICABLE FOR USE WITH THIS PART.
- DIMENSIONS IN [ ] ARE IN METRIC.
- FACEPLATE ACCEPTS 4 MINI-COM MODULES.
- FACEPLATE SNAPS INTO A RANGE OF FURNITURE OPENINGS:  
HEIGHT: 1.88" [ 47.5 ] TO 1.91" [ 48.5 ]  
WIDTH: 2.98" [ 75.7 ] TO 3.16" [ 80.2 ]  
MAX. MATERIAL THICKNESS: .090" [ 2.3 ]

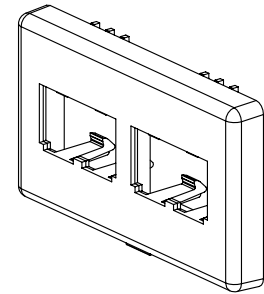
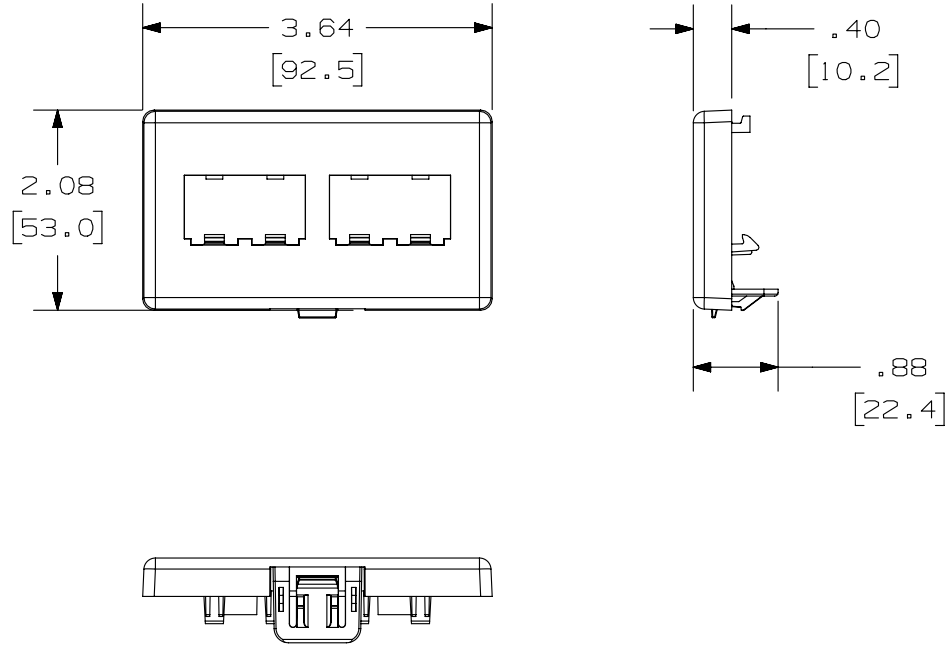

|  |          |                 |       |
|--|----------|-----------------|-------|
| PART NUMBER  |          | CFFPHM4**       |       |
| TITLE  |          |                 |       |
| MINI-COM 4 POSITION MODULAR FURNITURE FACEPLATE<br>FOR HERMAN MILLER BELTLINE SERIES |          |                 |       |
| CUSTOMER DRAWING   |          |                 |       |
| ITEM REVISION NAME   |          | M00453BA/05     |       |
| DATASET FILE NAME  |          | M00453BA_DC/05B |       |
| UNLESS OTHERWISE SPECIFIED,<br>DIMENSIONAL TOLERANCES ARE: IN [ mm ]                 |          | MATERIAL:       |       |
| .x ± .xx ± .03 [ .8 ]  |          | ABS             |       |
| .xxx ± .010 [ .3 ]   |          | DRAWING NUMBER: |       |
| ANGLES ±   |          | 00453-02        |       |
| THIRD ANGLE PROJECTION   |          | SHT 1 OF 1      |       |
| DRAWN BY   | DATE     | CHK             | SCALE |
| JSP  | 8-9-01   | CVM             | NONE  |
| REV  | DATE     | BY              | CHK   |
| 2  | 3/18/14  | JSP             | REFR  |
| 1  | 11-13-02 | JSP             | CEF   |
| R  | 8-9-01   | JSP             | CVM   |
| DESCRIPTION  |          | ECN             |       |
| B. REVISED DRAWING TITLE BLOCK.  |          | 00453-02        |       |
| A. ADDED NOTE #4 AND 5.  |          | 00453-02        |       |
| RELEASED TO PRODUCTION   |          | 00453-02        |       |

D10100DA/14