

THIS IS A CONTROLLED DOCUMENT.

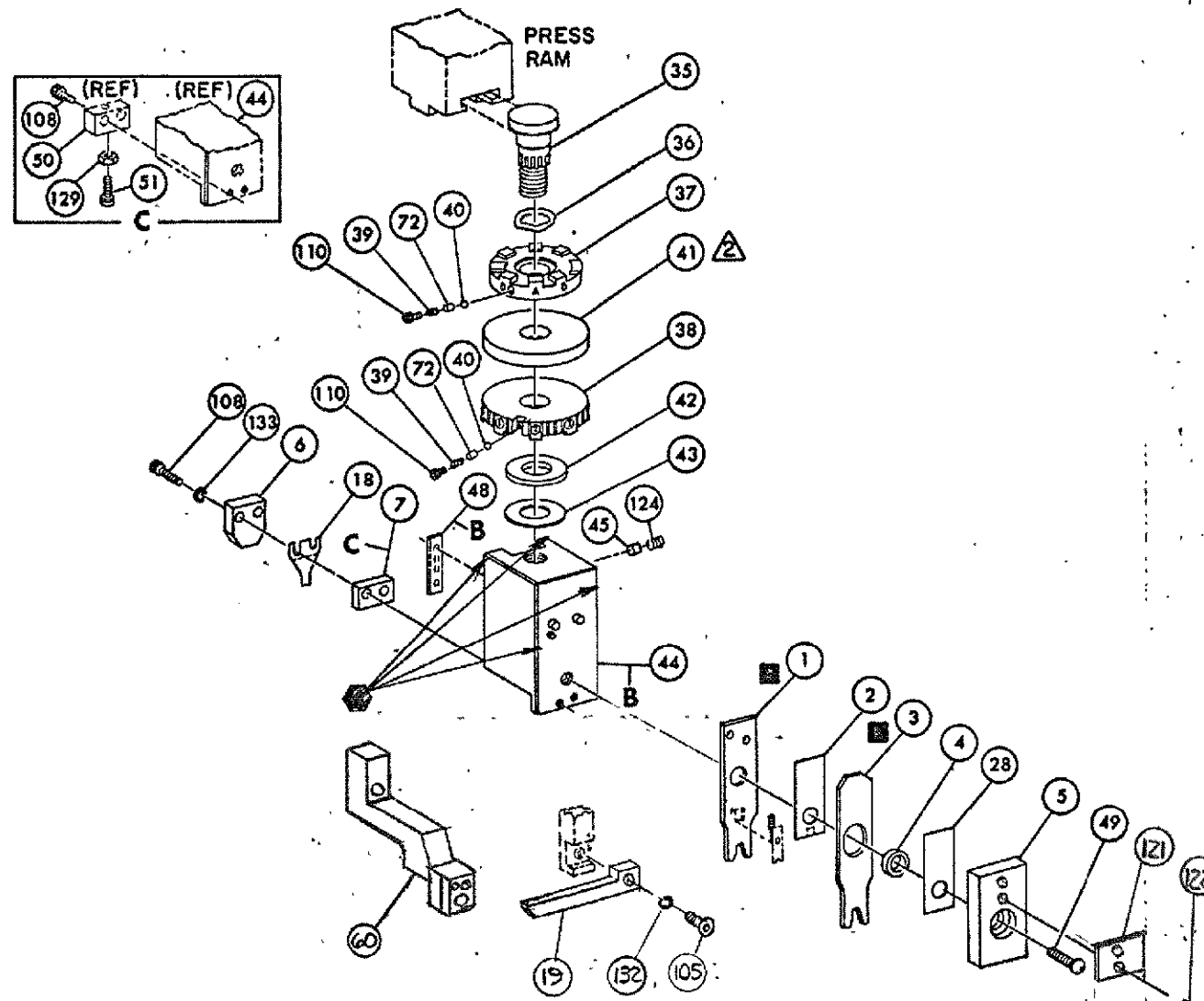
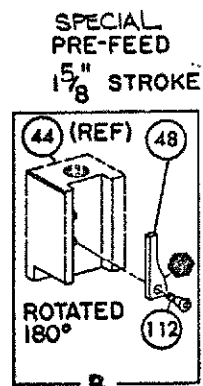

**NOTES:**

1- ONLY THE ITEMS WITH QUANTITIES SPECIFIED ON PARTS LIST ARE USED ON THIS APPLICATOR.

△- USED IN PLACE OF ITEM 38 WHEN INSULATION CRIMP IS NOT USED.

3- FEED PIVOT-BOTTOM HOLE

**KEY:**

■- RECOMMENDED SPARE PARTS

⊙- GREASE WEEKLY

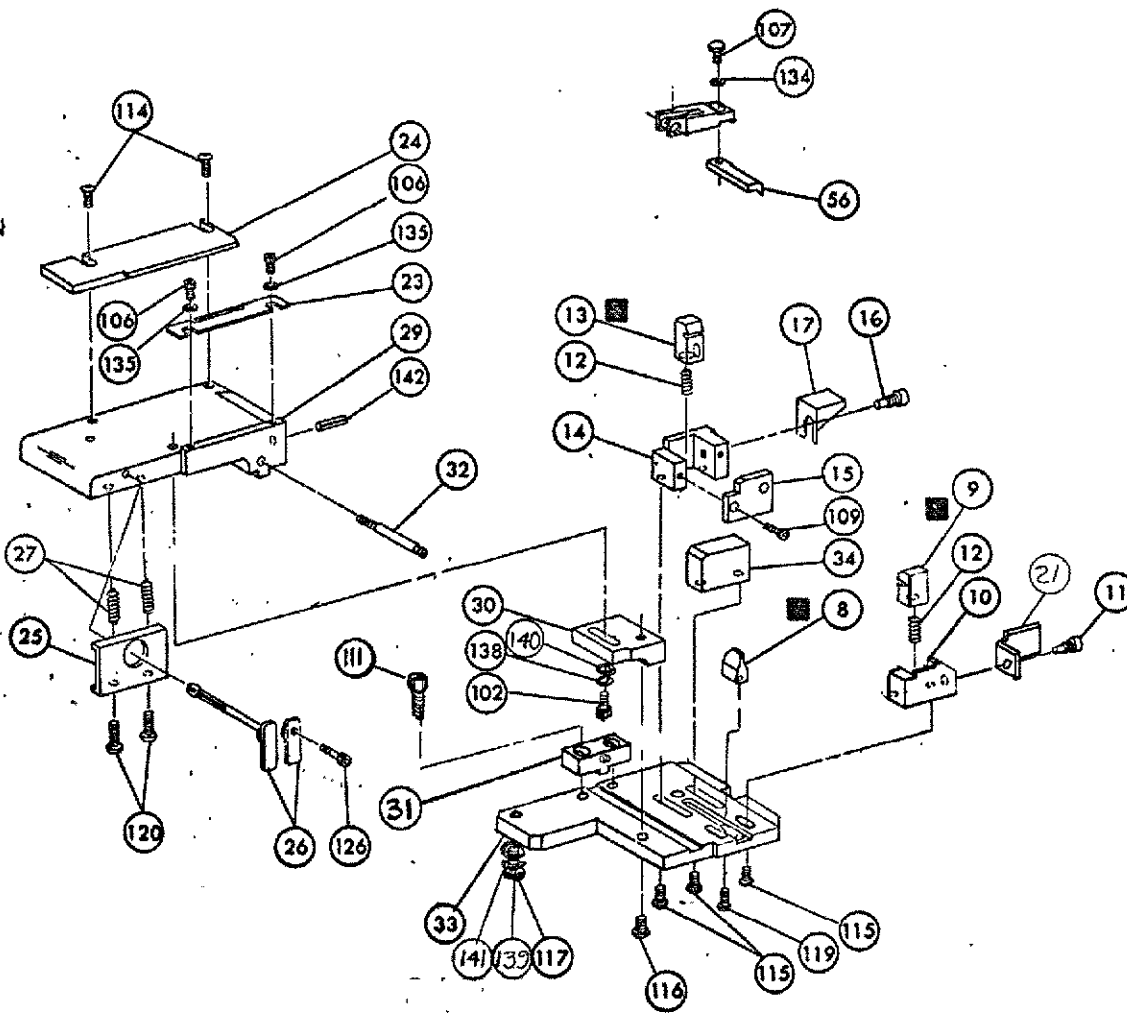

| QTY | PART NO   | DESCRIPTION                                      | ITEM NO |
|-----|-----------|--|---------|
| 1   | 4-21028-0 | PIN, SLOT SPR (.093 DIA X .75) STR G PLATE       | 142     |
| 1   | 21899-2   | WASHER, FLAT (NO 10) MOUNTING-                   | 141     |
| 1   | 21899-2   | WASHER, FLAT (NO 10) S. G. ADJ BLOCK             | 140     |
| 1   | 21024-5   | WASHER, LOCK (NO 10) MOUNTING-                   | 139     |
| 1   | 21024-5   | WASHER, LOCK (NO 10) STRIP GUIDE ADJ BLOCK       | 138     |
|     |           |  | 137     |
|     |           |  | 136     |
| 2   | 21057-2   | WASHER, LOCK (NO 4) FRONT STRIP GUIDE            | 135     |
| REF | 21024-4   | WASHER, LOCK (NO 8) FEED FINGER                  | 134     |
| 2   | 21024-4   | WASHER, LOCK (NO 8) DEPRESSOR                    | 133     |
| REF | 21024-4   | WASHER, LOCK (NO 8) STRIPPER                     | 132     |
|     |           |  | 131     |
|     |           |  | 130     |
| 1   | 21068-5   | NUT, HEX MACH (6-32) HOLDDOWN                    | 129     |
|     |           |  | 128     |
|     |           |  | 127     |
|     |           |  | 126     |
|     |           |  | 125     |
| 1   | 21009-2   | SCR, SKT SET (1/4-20 X .25) (LOC-WEL) RAM        | 124     |
|     |           |  | 123     |
| 2   | 21017-2   | SCR, DRIVE (#2 X .185 LG)                        | 122     |
| 1   | 819347-1  | PLATE, I.D.                                      | 121     |
| 2   | 2-21002-9 | SCR, BUT HD SKT CAP (10-32 X .75) DRAG           | 120     |
| 1   | 22733-8   | SCR, BUT HD SKT CAP (8-32 X .38) (LOC-WEL) ANVIL | 119     |
|     |           |  | 118     |
| 1   | 3-21000-8 | SCR, SOG HD SKT CAP (10-32 X .88) MOUNTING       | 117     |
| 1   | 2-22733-1 | SCR, BUT HD SKT CAP (10-32 X .50) SG ADJ BLOCK   | 116     |
| 2   | 22733-9   | SCR, BUT HD SKT CAP (8-32 X .50) SHEAR           | 115     |
| 2   | 2-21002-2 | SCR, BUT HD SKT CAP (8-32 X .50) R STRIP GUIDE   | 114     |
|     |           |  | 113     |
| 1   | 1-21002-7 | SCR, BUT HD SKT CAP (6-32 X .50) CAM             | 112     |
| 2   | 2-21000-7 | SCR, SKT HD CAP (8-32 X .50) SCR. BLOCK          | 111     |
| 2   | 23030-1   | SCR, SKT HD CAP (6-32 X .25) (LOC-WEL) CP DISC   | 110     |
|     |           |  | 109     |
| 2   | 2-21000-5 | SCR, SKT HD CAP (8-32 X .25) DEPRESSOR (REAR)    | 108     |
| REF | 2-21002-1 | SCR, BUT HD MACH (8-32 X .38) FEED FINGER        | 107     |
| 2   | 1-21000-3 | SCR, SKT HD CAP (4-40 X .25) F STRIP GUIDE       | 106     |
| REF | 2-21002-1 | SCR, BUT HD CAP (8-32 X .38) STRIPPER            | 105     |
|     |           |  | 104     |
|     |           |  | 103     |
| 1   | 3-22603-1 | SCR, HEX HD CAP (10-32 X .38) SG ADJ BLOCK       | 102     |
|     |           |  | 101     |
|     |           |  | 79      |
|     |           |  | 78      |
| 2   | 463310-6  | BLADE, STRIPPING (# 22 )                         | 77      |
|     |           |  | 76      |
|     |           |  | 75      |
|     |           |  | 74      |
|     |           |  | 73      |
| 2   | 690603-1  | SPRING, ASSIST                                   | 72      |
|     |           |  | 71      |
|     |           |  | 70      |
|     |           |  | 69      |
|     |           |  | 68      |
|     |           |  | 67      |
|     |           |  | 66      |
|     |           |  | 65      |
|     |           |  | 64      |

| QTY | PART NO  | DESCRIPTION  | ITEM NO |
|-----|----------|--------------|---------|
| 1   | 463756-1 | GUIDE, SCRAP | 21      |
|     |          |              | 20      |
|     |          |              | 19      |
|     |          |              | 18      |
|     |          |              | 17      |
|     |          |              | 16      |
|     |          |              | 15      |
|     |          |              | 14      |
|     |          |              | 13      |
|     |          |              | 12      |
|     |          |              | 11      |
|     |          |              | 10      |
|     |          |              | 9       |
|     |          |              | 8       |
|     |          |              | 7       |
|     |          |              | 6       |
|     |          |              | 5       |
|     |          |              | 4       |
|     |          |              | 3       |
|     |          |              | 2       |
|     |          |              | 1       |

|                              |                |                   |
|------------------------------|----------------|-------------------|
| REMARKS                      | NO             | REV               |
| APPL USED ON MACHINE PART NO | MACH SERIAL NO | TO APPLY TERMINAL |
| CUSTOMER NAME                | APPL SERIAL NO | DISTRIBUTION      |
| ADDRESS                      | PURCHASE ORDER | ORIGINAL          |
| CITY                         | ENG APP        | CUSTOMER COPY     |
|                              |                | FIELD ENG COPY    |

| P/F LTR | REVISION | RECORD | APP DATE | P/F LTR | REVISION | RECORD | APP DATE |
|---------|----------|--------|----------|---------|----------|--------|----------|
|         |          |        |          |         |          |        |          |
|         |          |        |          |         |          |        |          |
|         |          |        |          |         |          |        |          |
|         |          |        |          |         |          |        |          |

DATE: 00779 CUSTOMER AND ASSEMBLY DRAWING RESTRICTED TO

1667-7-1