

DESCRIPTION	MATERIAL	FINISH
BODY	BRASS	NICKEL
SOCKET	BRASS	GOLD
INSULATION	PTFE	N/A
WASHER	BRASS	NICKEL
NUT	BRASS	NICKEL

REVISIONS			
REV	DESCRIPTION	DATE	APPV
B	UPDATED FOOTPRINT AND DIMENSIONS; ADDED NEW TITLE BLOCK	29-JUN-12	SAH
C	ADDED DIMPLE TO PART	24-MAY-13	SAH

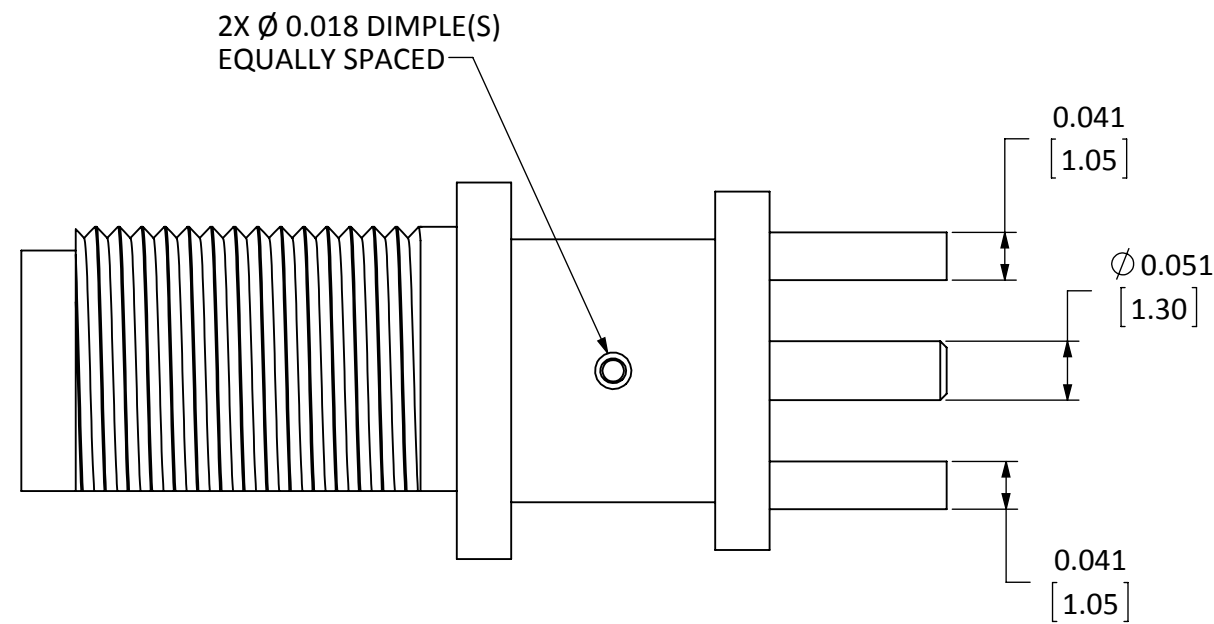

TOP VIEW

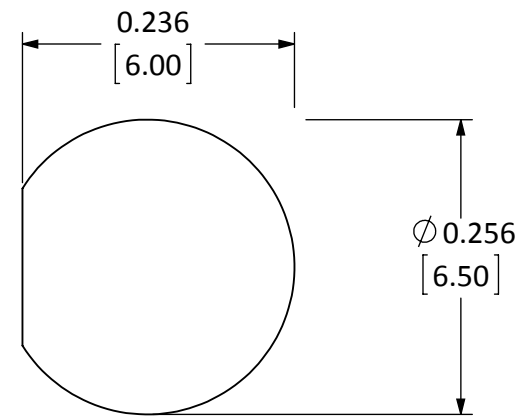

RECOMMENDED MOUNTING HOLE

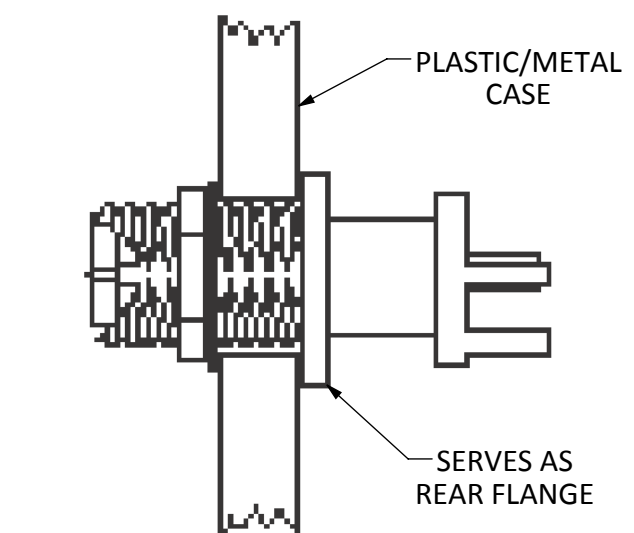
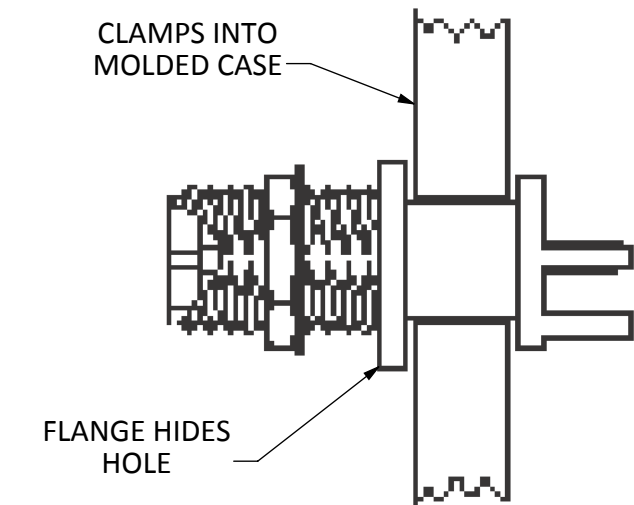
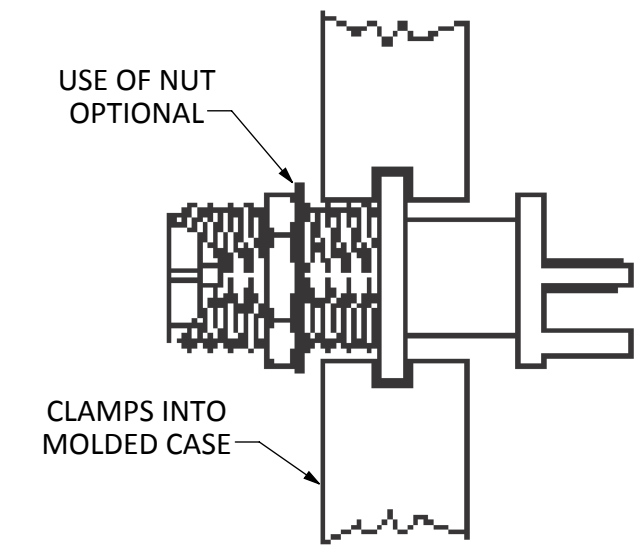

MOUNTING METHODS

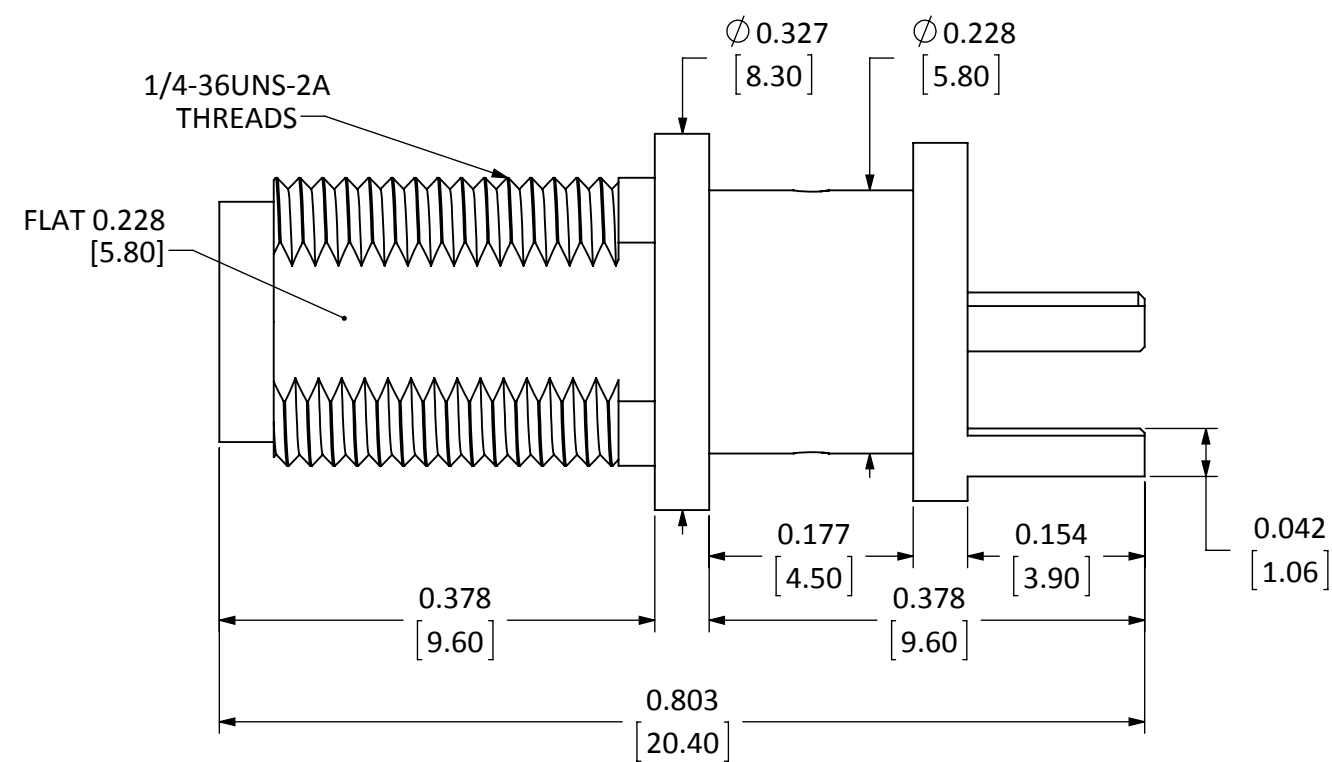

SIDE VIEW

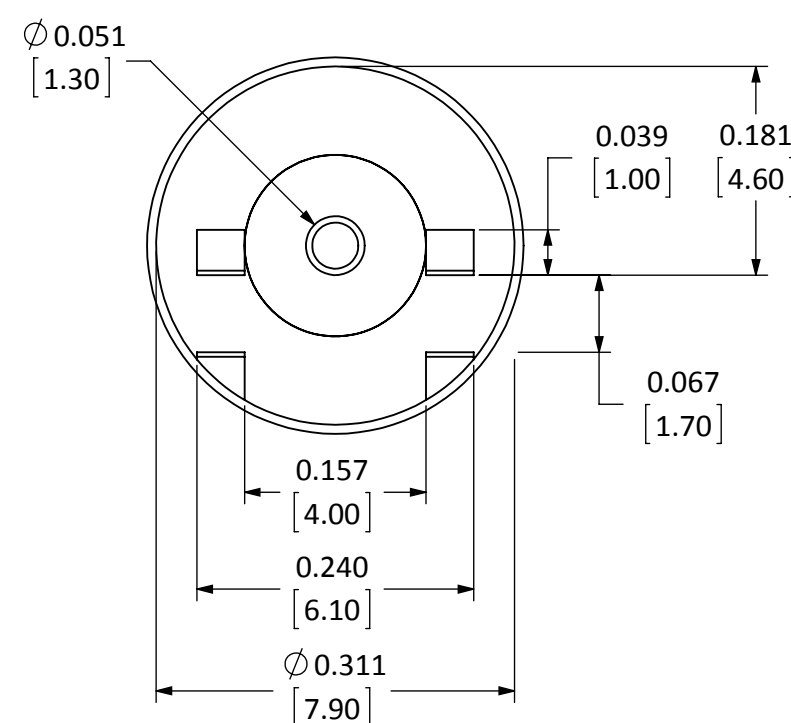

BACK VIEW

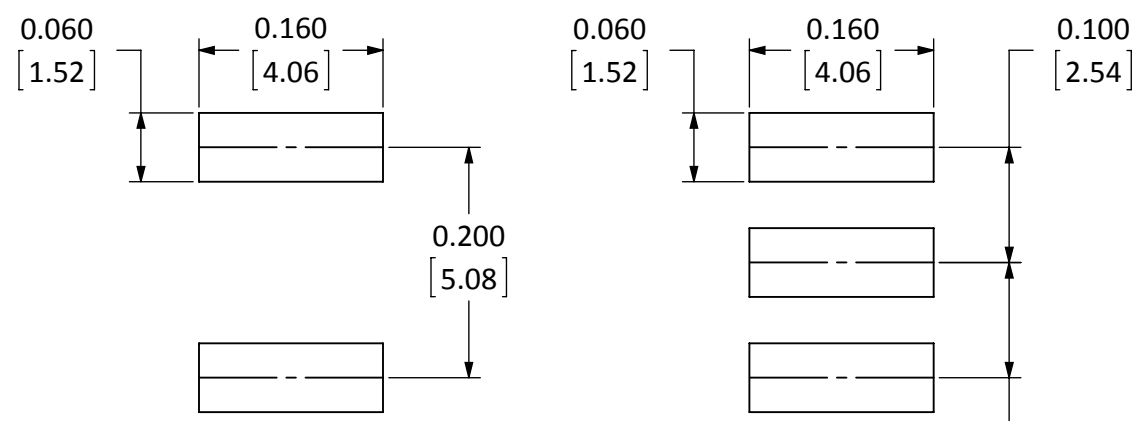

BOTTOM

TOP

RECOMMENDED FOOTPRINT

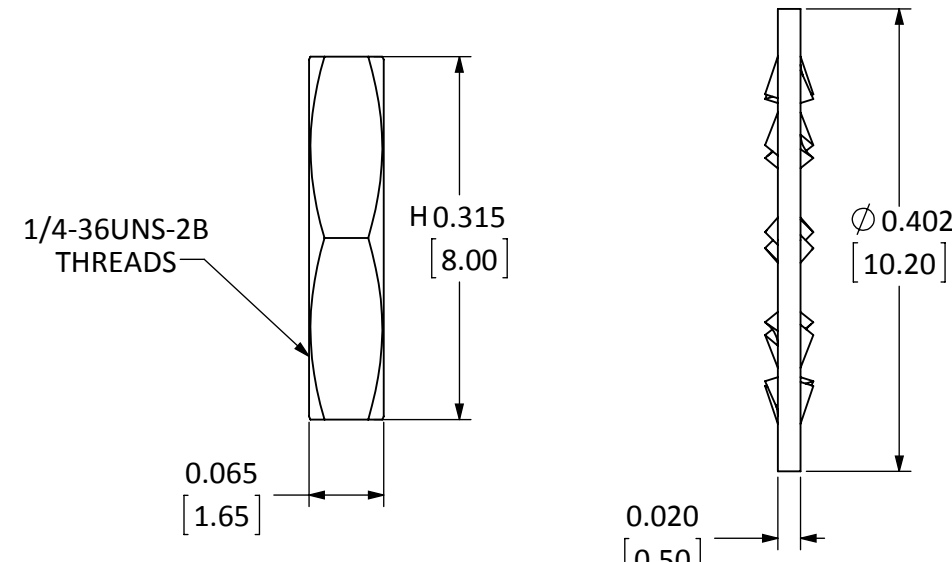

NUT

WASHER

- NOTES: (UNLESS OTHERWISE SPECIFIED)
1. ALL DIMENSIONS ARE IN INCHES [mm].
  2. DIMENSIONS APPLY AFTER FINISHING.
  3. MANUFACTURE TO BE COMPLIANT WITH EU RoHS DIRECTIVE.
  4. SAFETY BREAK ALL SHARP CORNERS AND EDGES .02 MAXIMUM.

**WARNING:** THIS DRAWING CONTAINS PROPRIETARY INFORMATION THAT IS THE SOLE PROPERTY OF LINX TECHNOLOGIES, AND SHALL BE TREATED AS SUCH. NO DISCLOSURE OR REPRODUCTION OF THIS DOCUMENT IS PERMITTED, IN WHOLE OR IN PART, WITHOUT THE EXPRESS WRITTEN PERMISSION OF LINX TECHNOLOGIES OR ITS DESIGNATED AGENTS.

**Linx** 159 ORT LANE  
MERLIN, OR 97532

TITLE: **SMA FEM EDGE MULTI-MOUNT FOR 0.062" THICK BOARD**

MATERIAL: INTERPRET DIMENSIONS AND TOLERANCES PER ASME Y14.5. SURFACE FINISH: ✓ ANGLER: ±1° TOLERANCES: .X ±.1 .XX ±.01 .XXX ±.005

FINISH: DRAWN: B.MURPHY DT: 14-MAY-13 ENGR: S.HOGAN DT: 24-MAY-13

PROJECTION: SIZE DWG. NO. **C** CON SMA006.062 REV **C**

SCALE: 6:1 DO NOT SCALE DRAWING SHEET 1 OF 1