

LOC	DIST	REVISIONS					
AF	50	P	LTR	DESCRIPTION	DATE	DWN	APVD
			F1	REV PER ECR-11-003939	22FEB11	JR	PD

1 CONTINUOUS STRIP ON REELS.
 2 TIN PLATE 0.00381 [.000150] MIN OVER
 0.00254 [.000100] MIN THK COPPER OR
 TIN PLATE 0.00381 [.000150] MIN OVER
 0.00127 [.000050] MIN THK NICKEL.

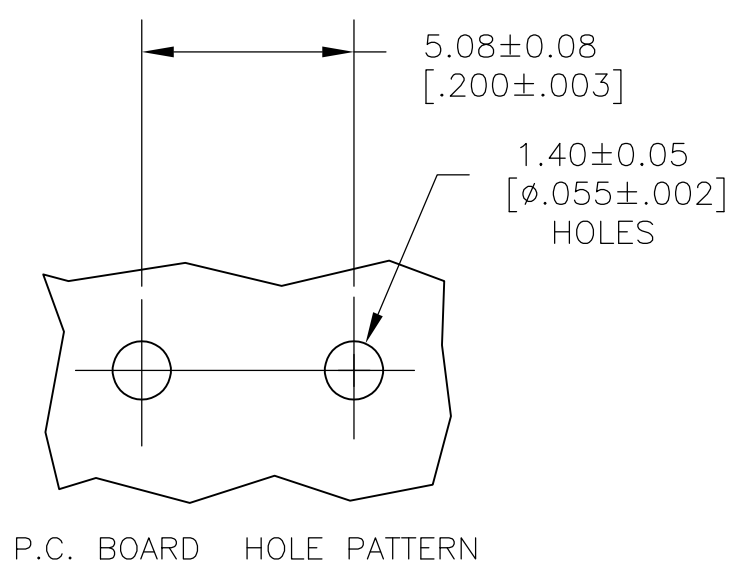
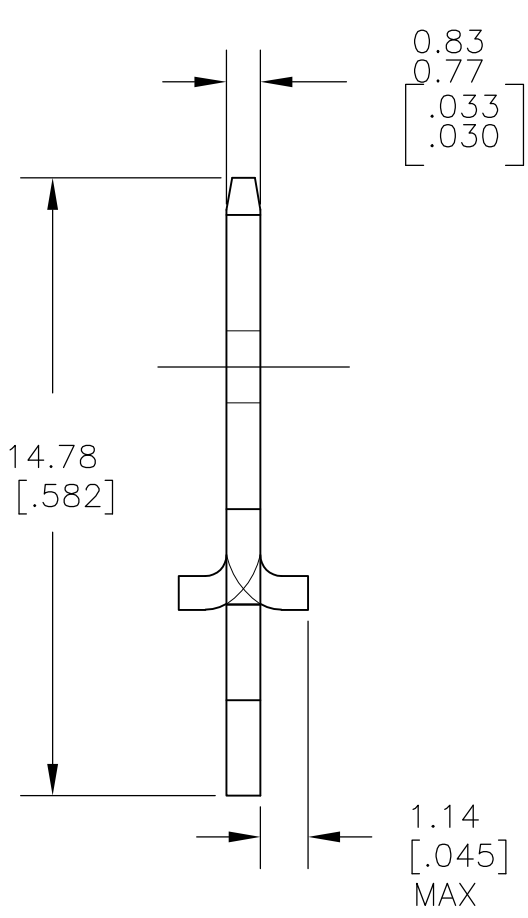
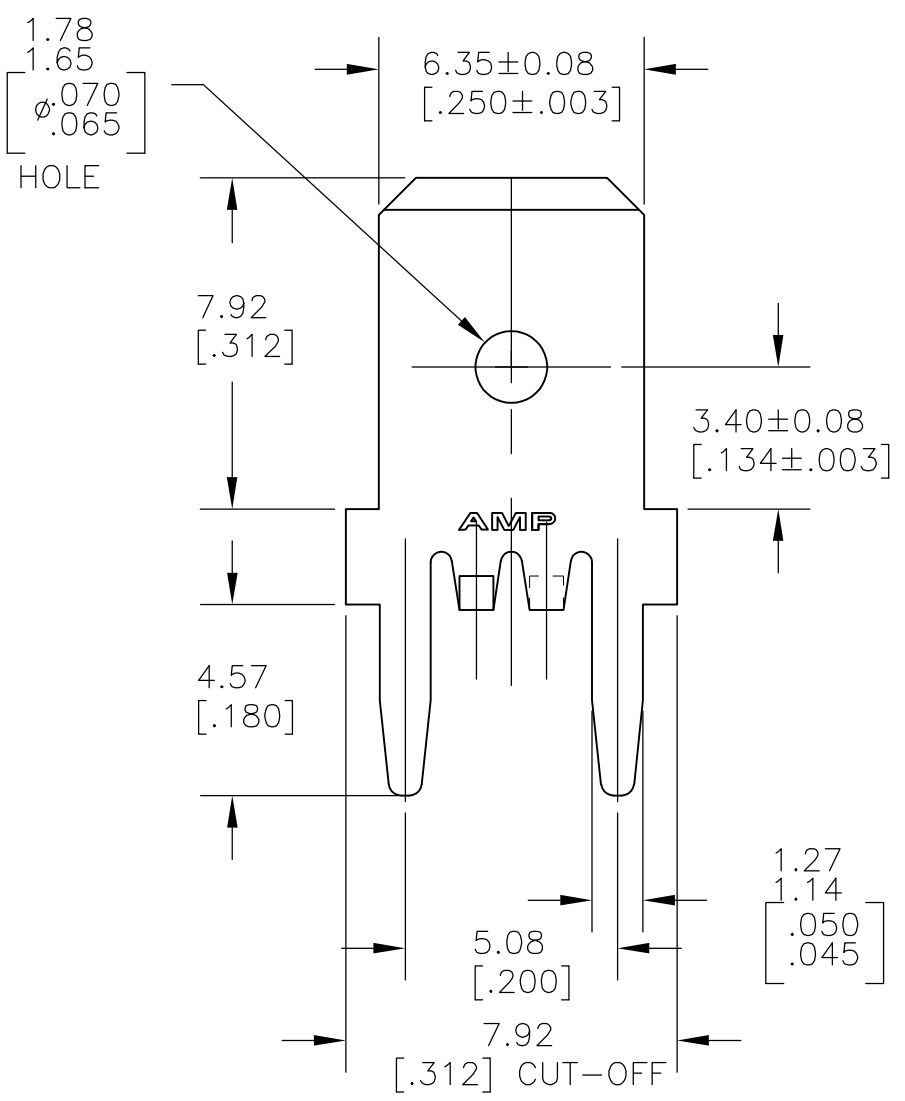

REVERSE REELING	1217136-2
	1217136-1
	PART NO.

THIS DRAWING IS A CONTROLLED DOCUMENT.		DWN JR RUTH 28MAR01	Tyco Electronics Corporation Harrisburg, PA 17105-3608													
DIMENSIONS: mm [INCHES]		CHK MS FEHER 28MAR01	NAME TAB, FASTON, P.C.BOARD 6.35 [.250]													
TOLERANCES UNLESS OTHERWISE SPECIFIED:		APVD N DEIBERT 28MAR01	PRODUCT SPEC -													
<table border="0"> <tr><td>0 PLC</td><td>± -</td></tr> <tr><td>1 PLC</td><td>± -</td></tr> <tr><td>2 PLC</td><td>± 0.25 [.010]</td></tr> <tr><td>3 PLC</td><td>± -</td></tr> <tr><td>4 PLC</td><td>± -</td></tr> <tr><td>ANGLES</td><td>± -</td></tr> </table>		0 PLC	± -	1 PLC	± -	2 PLC	± 0.25 [.010]	3 PLC	± -	4 PLC	± -	ANGLES	± -	APPLICATION SPEC 114-2115	SIZE A3	CAGE CODE 00779
0 PLC	± -															
1 PLC	± -															
2 PLC	± 0.25 [.010]															
3 PLC	± -															
4 PLC	± -															
ANGLES	± -															
MATERIAL 082 BRASS	FINISH 2	WEIGHT -	DRAWING NO C-1217136	RESTRICTED TO -												
CUSTOMER DRAWING			SCALE 6:1	SHEET 1 of 1												
			REV F1													