

4

3

2

1

REVISIONS				
ZONE	LTR	DESCRIPTION	DATE	APPROVED
	A	INITIAL RELEASE NUM: 70090-311		
	B	(CLII) SEE ECN 27219	6-1-93 R. Prescott	R. Prescott
	C	(CLII) SEE CHG NOTICE ECN: 92275	3-17-04 PRESCOTT	P

15	1		10-581819-XXI	SLEEVE	10
14	1		SEE COLUMN	GROMMET	10,13
13	1		10-590986-XX3	ADAPTER	10
12	1		10-748XX-()S	INSERT, SOCKET	4
12	1		10-748XX-()P	INSERT, PIN	4
11		SEE NOTE 8		CONTACT	2,3
10	1		SEE COLUMN	CABLE CLAMP	
9	1		SEE COLUMN	SLEEVE	
8	1		SEE COLUMN	ELBOW ASSEMBLY	3
7	1		10-564869-XX	SLEEVE	12
6	1		10-607XX-()	GROMMET	12,13
5	1		10-564859-XX	WASHER, WAVED	
4	1		10-564860-XX	WASHER, SKID	
3	1		10-564843-XXI	GASKET	
2	1		10-564856-XX3	NUT, COUPLING	
1	1		SEE COLUMN	SHELL	

UNLESS OTHERWISE SPECIFIED
LINEAR DIMENSIONS ARE IN
INCHES.
TOLERANCES: .XXX±.010,
.XX ±.03, .X ±.1,
ANGLES ±2°.
OTHER STANDARDS PER 9-3800
AND DOD-D-1000.
NOTE REF. = 

COMPANY ID: 2
CODED/MS/CUST: Y
INTERNAL: N
LOTNO: N
DATE CODE: 9-3895
SEE PRINT: N

N/A
N/A
NEXT ASSEMBLY

FIND NO.	QTY REOD.	FSCM NO.	PART NUMBER	DESCRIPTION	NOTE REF.
PARTS LIST					
SPECIFICATIONS		SIGNATURES		DATES	
MATERIAL SPEC.		PREPARED PRESCOTT		2/5/90	
N/A		CHECKED <i>H. Conde</i>		8-30-90	
PROCESS SPEC.		APPROVED <i>H. Conde</i>		8-30-90	
SEE NOTE 5		APPROVED <i>R. Prescott</i>		9-4-90	
		1ST PART NO.		71-580862-28P	
		SIZE	FSCM NO.	REV.	
		C	77820	C	
		SCALE	WT.	REF	SHEET
		NONE		71-580410/429	1 OF 3

SEE SHEET 2.
NOTES:

THE USE OF THIS DOCUMENT IS UNLIMITED.
HOWEVER, DOCUMENTS REFERENCED HEREON
MAY CONTAIN LIMITED RIGHTS DATA.

71-580850/869
SCANNED

8/26/90 07:17 * 90287 07:13 * PRELISE * 71-580850/869 A001

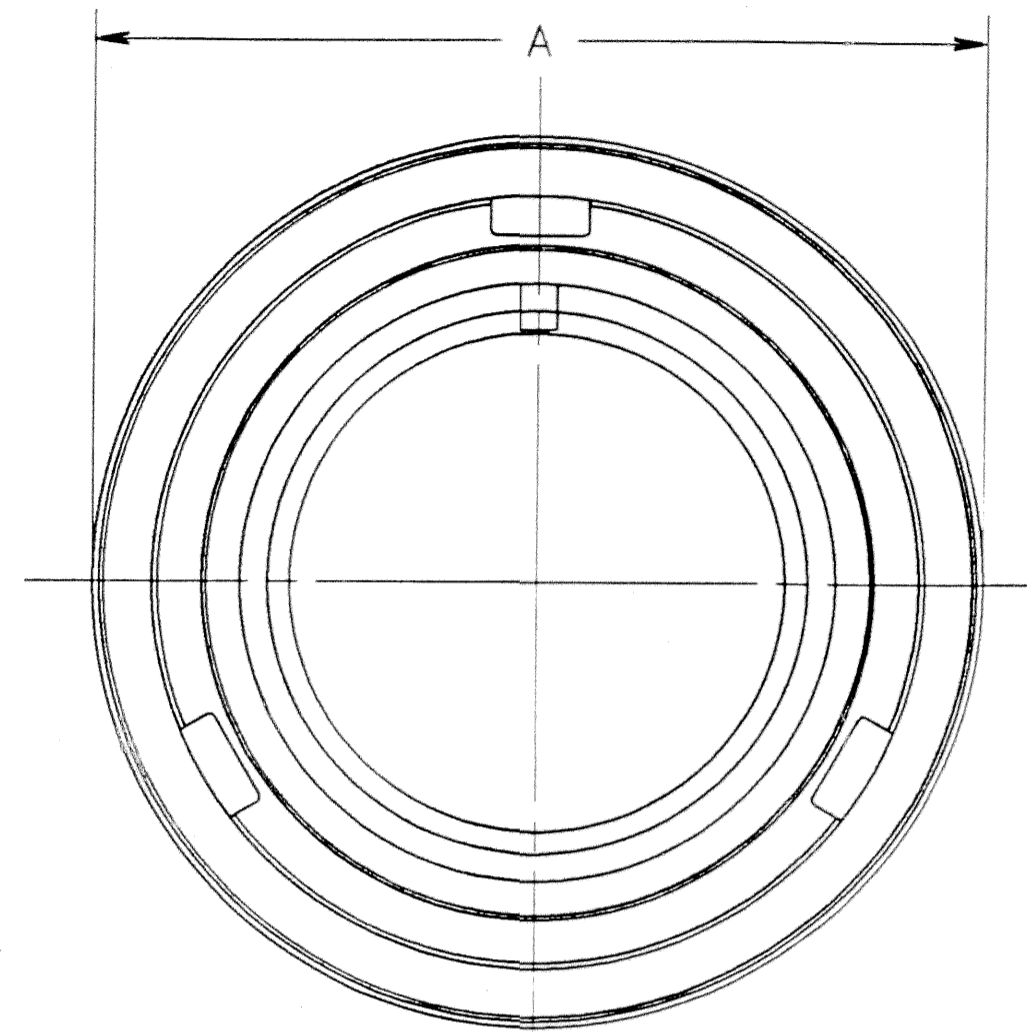
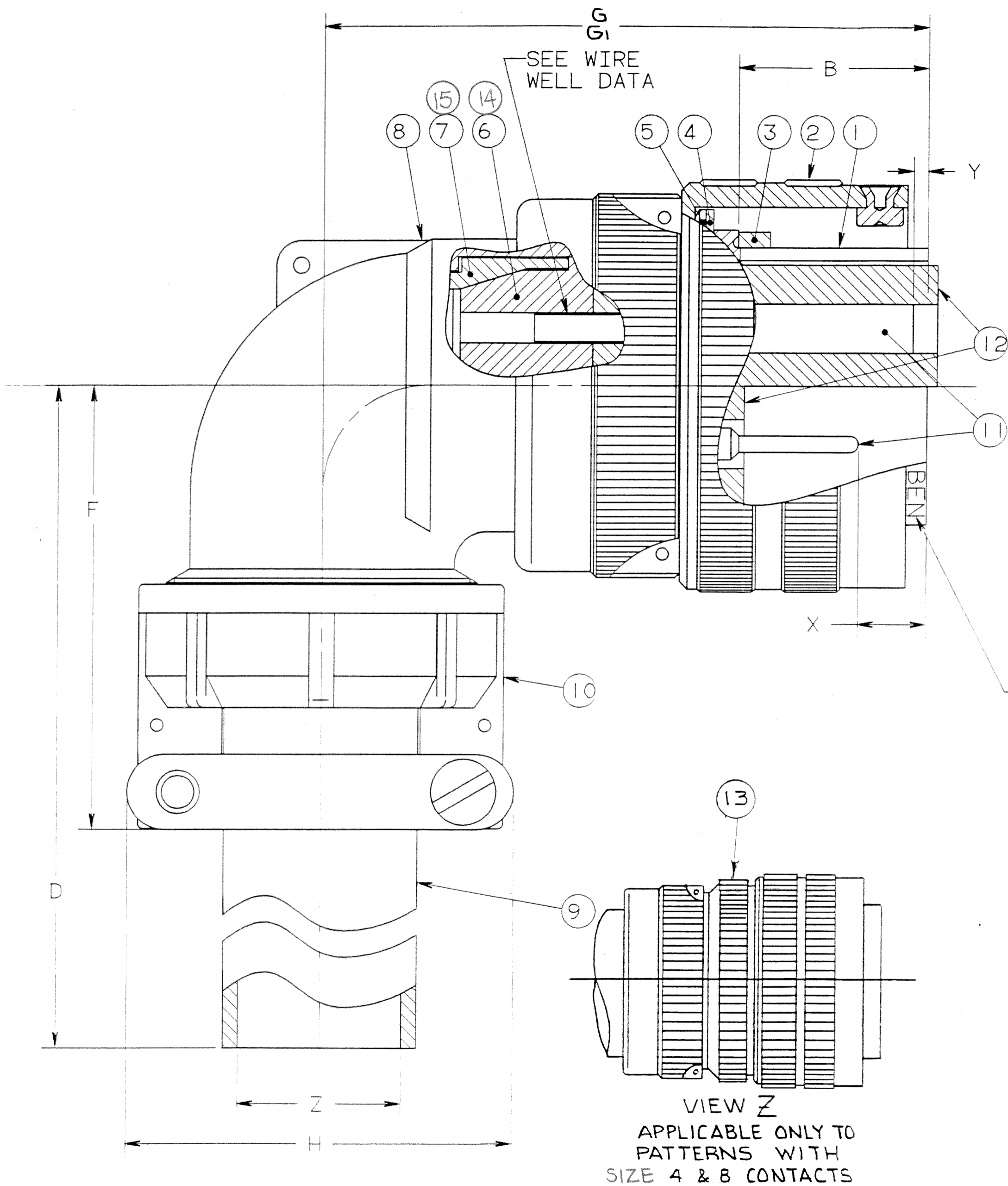

BLACK INK STAMP PER 9-3856-5 "BENDIX", GT NUMBER, (SEE COLUMN), AND DATE CODE, (9-3895), .062-.094 HIGH.
 EXAMPLE: BENDIX GTC08F24-2P 9052 6

NOTES:

THE USE OF THIS DOCUMENT IS UNLIMITED. HOWEVER, DOCUMENTS REFERENCED HEREON MAY CONTAIN LIMITED RIGHTS DATA.

SIZE	FSCM NO.	71-580850/869	REV.
C	77820		C
SCALE	WT.	REF	SHEET 2

2/29/90 09:13 * 90241 09:12 * PHL:SE * 71-580850/869 A002

4

3

2

1

ASSEMBLY NUMBER	SHELL SIZE	GT NUMBER	SHELL	GROMMET	ELBOW ASSEMBLY	CABLE CLAMP	SLEEVE	A DIA MAX	B ±.005	D MAX	F MAX	G MAX	H MAX	Z MAX
71-580850-()	8S	NOT AVAILABLE												
71-580851-()	10S	NOT AVAILABLE												
71-580852-()	10SL	GTC08F10SL-()	10-580915-113	10-581825-()	10-580892-113	10-824810- 4	10-824802- 4	.897	.531	3.937	1.654	1.772	.894	.220
71-580853-()	12S	NOT AVAILABLE												
71-580854-()	12	NOT AVAILABLE												
71-580855-()	14S	GTC08F14S-()	10-37266-14	10-581827-()	10-580892-143	10-824810- 7	10-824802- 6	1.150	.531	3.937	1.654	1.850	1.083	.312
71-580856-()	14	NOT AVAILABLE												
71-580857-()	16S	GTC08F16S-()	10-37266-16	10-581829-()	10-580892-163	10-824810- 8	10-824802- 8	1.300	.531	3.937	1.772	1.890	1.181	.437
71-580858-()	16	GTC08F16-()	10-37266-17	10-581830-()	10-580892-173	10-824810- 8	10-824802- 8	1.300	.719	3.937	1.772	2.244	1.181	.437
71-580859-()	18	GTC08F18-()	10-37266-18	10-581831-()	10-580892-183	10-824810-10	10-824802-10	1.437		3.937	2.087	2.283	1.299	.562
71-580860-()	20	GTC08F20-()	10-37266-20	10-581832-()	10-580892-203	10-824810-12	10-824802-12	1.571		3.937	2.087	2.402	1.476	.625
71-580861-()	22	GTC08F22-()	10-37266-22	10-581833-()	10-580892-223	10-824810-12	10-824802-12	1.697		3.937	2.087	2.402	1.476	.625
71-580862-()	24	GTC08F24-()	10-37266-24	10-581834-()	10-580892-243	10-824810-16	10-824802-16	1.835		3.937	2.283	2.598	1.705	.750
71-580863-()	28	GTC08F28-()	10-37266-28	10-581835-()	10-580892-283	10-824810-16	10-824802-16	2.102		3.937	2.283	2.598	1.705	.750
71-580864-()	32	GTC08F32-()	10-37266-32	10-581836-()	10-580892-323	10-824810-20	10-824802-20	2.366		4.331	2.598	2.835	2.061	.937
71-580865-()	36	GTC08F36-()	10-37266-36	10-581837-()	10-580892-363	10-824810-24	10-824802-24	2.610		4.331	2.717	2.953	2.283	1.250
71-580866-()	40	NOT AVAILABLE												
71-580867/869-()		NOT AVAILABLE												

TO COMPLETE, ADD APPLICABLE INSERT ARRANGEMENT SUFFIX PER 9-2437.

ASSEMBLY NUMBER	G1 MAX
71-580850 - ()	---
851 - ()	---
852 - ()	---
853 - ()	---
854 - ()	---
855 - ()	---
856 - ()	---
857 - ()	---
858 - ()	3.056
859 - ()	3.095
860 - ()	3.213
861 - ()	3.415
862 - ()	3.232
863 - ()	3.692
864 - ()	3.908
865 - ()	4.171
866 - ()	---
71-580867/869	---

13. TO COMPLETE GROMMET PART NO., ADD APPLICABLE ARRANGEMENT SUFFIX.
12. INDICATED ITEMS, (FN/S 6 & 7), ARE APPLICABLE TO CONNECTORS CONTAINING CONTACT ARRANGEMENTS OTHER THAN THOSE SPECIFIED IN NOTE 10.
11. INDICATED LENGTH APPLIES TO CONNECTORS WITH CONTACT PATTERNS CONTAINING 5Z 4 OR 8 CONTACTS.
10. INDICATED ITEMS, (F/N'S 13, 14 & 15), ARE APPLICABLE TO CONNECTORS CONTAINING CONTACT ARRANGEMENTS WITH SIZE 4 OR 8 CONTACTS.
9. PACKAGE PER PRODUCTION PROCESS SHEET.
8. SEE SEPARATE PARTS LIST FOR COMPONENT PART NUMBERS AND QUANTITIES.
7. FOR MATING CONNECTOR ASSEMBLIES, SEE 71-580960/979 AND OTHERS.
6. SEE WORK ORDER FOR PERMISSIBLE ADDITIONAL OR ALTERNATE STAMPING.
5. PROCESS SPEC:
 ASSY 9-9238
 TEST 9-3106-18
 9-3856-5, 9-3895, 9-2437
4. INSERTS ARE NOT REMOVABLE.
3. DRAWING ILLUSTRATES FINAL ASSEMBLY. FOR STORAGE AND SHIPPING ELBOW ASSEMBLY AND CLAMP ASSEMBLY MUST BE LOOSELY COUPLED. CONTACTS ARE SHIPPED UNASSEMBLED. FOR FINAL INSTALLATION, CONTACTS MUST BE ASSEMBLED INTO ALL INSERT HOLES. ALL UNUSED GROMMET HOLES MUST BE FILLED WITH THE APPROPRIATE SIZE SEALING PLUG.
2. FOR CONTACT SIZE, SPACING AND SERVICE RATING, SEE MIL-STD-1651 OR L-11908-() THRU L-11948-().
1. UNIT MEETS THE APPLICABLE REQUIREMENTS OF MIL-C-5015.

CONTACT SIZE	SHELL SIZE	X	Y ±.040
16 SHORT	10SL, 14S, 16S	.087±.039	.079
16 LONG	16 THRU 40	.260 ^{+.052} -.041	.102
12	16 THRU 40	.118 ^{+.039} -.056	.102
4, 8, 0	16 THRU 40	.091±.039	.102

WIRE WELL DATA					
CONTACT SIZE	0	4	8	12	16
WELL DIA	.453±.005	.281 ^{+.005} -.004	.179 ^{+.004} -.002	.098 ^{+.004} -.001	.063 ^{+.004} -.001
WELL DEPTH	^{+.031} -.000	.592	.500	.500	.250

NOTES:

THE USE OF THIS DOCUMENT IS UNLIMITED. HOWEVER, DOCUMENTS REFERENCED HEREON MAY CONTAIN LIMITED RIGHTS DATA.

SIZE	FSCM NO.	REV.
C	77820	71-580850/869
SCALE	WT.	REF
NONE		N/A
SHEET	3	

71-580850/869

SCANNED