

THIS DRAWING IS UNPUBLISHED. RELEASED FOR PUBLICATION, 19 .
 © COPYRIGHT 19 BY AMP INCORPORATED. ALL INTERNATIONAL RIGHTS RESERVED.

LOC	DIST	P	F	ZONE	LTR	DESCRIPTION	DATE	APPD
AF	50				G	REV PER 0G3A-0234-02	02MAY02	JR/GP

- 1 CONTINUOUS STRIP ON REEL.
- 2 FOREIGN PRODUCTION ONLY.
- ③ CRIMP WIDTH: .090, F TYPE
 CRIMP HEIGHT $\pm .002 = (\text{TOTAL CMA} + 6470) / 142,800$
 FOR APPLICATOR INFORMATION CALL: 1-800-722-1111
 FOR PRODUCT INFORMATION CALL: 1-800-522-6752

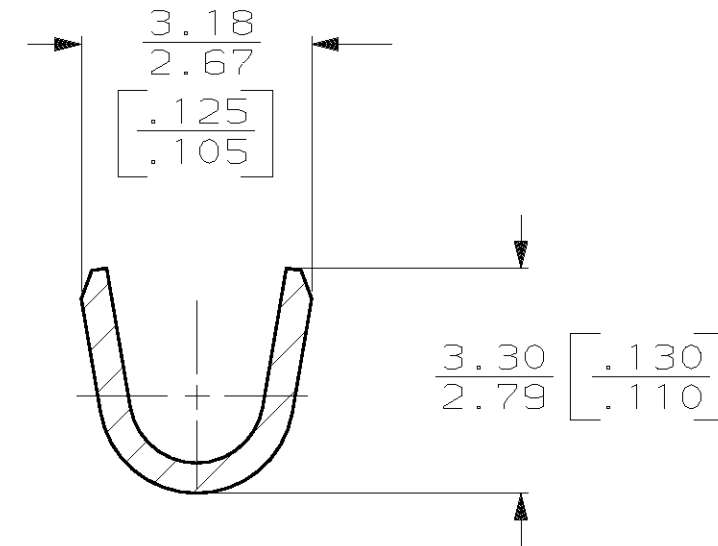
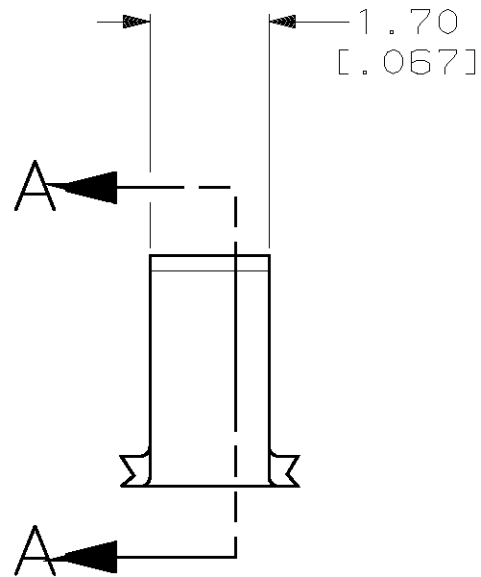
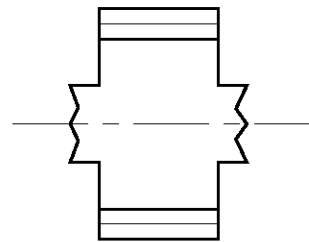

SECTION A-A

800-2500 CMA	41313
WIRE RANGE ③	PART NO

DO NOT SCALE PRINT. UNLESS SPECIFIED DIMENSIONS IN mm [INCHES] TOLERANCES ON: 2 PLC DEC ± 0.25 [.010] 3 PLC DEC $\pm -$ ANGLES $\pm -$	DR 8/9/94 PHILLIP M. FORTNEY
	CHK 8/9/94 JEFF R. RUTH
MATERIAL 082 BRASS	APPD 8/9/94 DENNIS SCHWENK
	APPD 8/9/94 RON KUZO
FINISH 0.002032 [.000080] MIN TIN PL PER MIL-T-10727	PRODUCT SPEC -
	APPLICATION SPEC -
	WEIGHT -

AMP AMP Incorporated Harrisburg, PA 17105-3608	
NAME SPLICE	
SIZE B	CAGE CODE 00779
DRAWING NO C-41313	
SCALE 10:1	SHEET 1 OF 1

THIS DRAWING IS A CONTROLLED DOCUMENT FOR AMP INCORPORATED. IT IS SUBJECT TO CHANGE AND THE CONTROLLING ENGINEERING ORGANIZATION SHOULD BE CONTACTED FOR THE LATEST REVISION.