

PART NAME: KNOB

SCALE: 1:1

DATE: 3/5/09

DR. BY JAM

DAVIES MOLDING COMPANY  
CAROL STREAM, ILLINOIS 60188

P/N 1505-B

THIS DRAWING IS THE PROPERTY OF DAVIES MOLDING COMPANY, IS SUBMITTED SOLELY AS A DESIGN OR ENGINEERING PROJECT.  
WE ACCEPT NO RESPONSIBILITY WHATSOEVER FOR THE PRACTICAL APPLICATION OF THE PIECES MADE TO THIS DESIGN.

(A)  
(B)

BASE PART 1505-02  
SET SCREW I1266

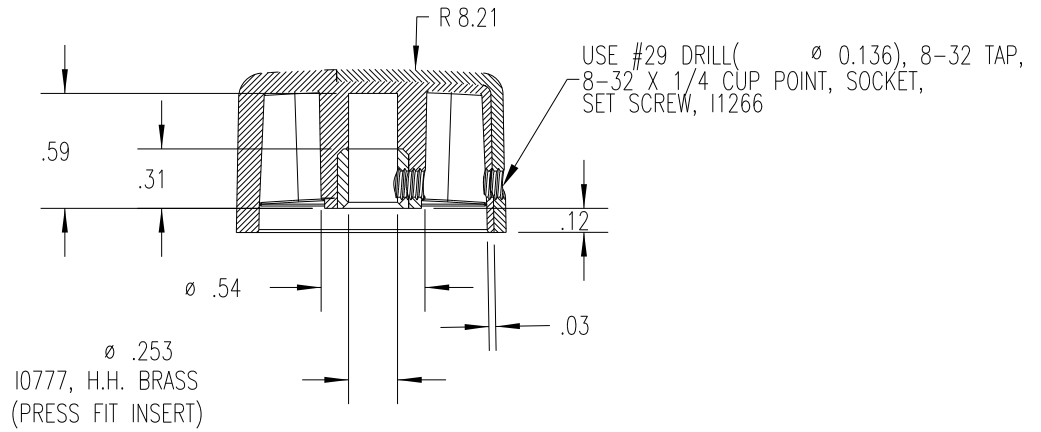
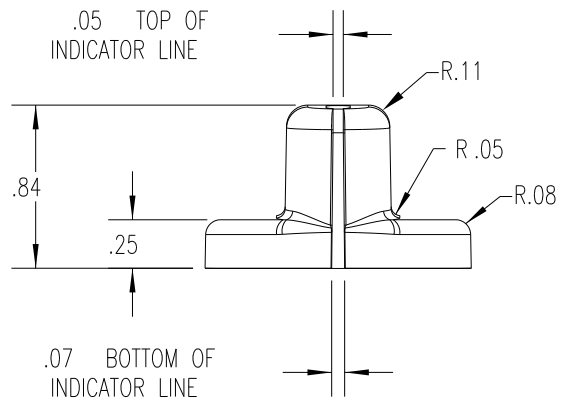
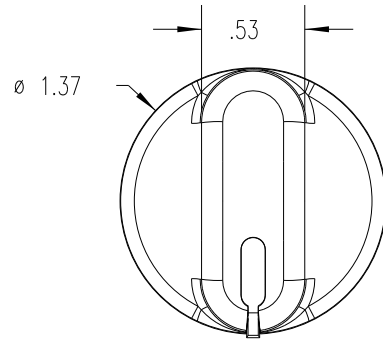

SECTION A-A

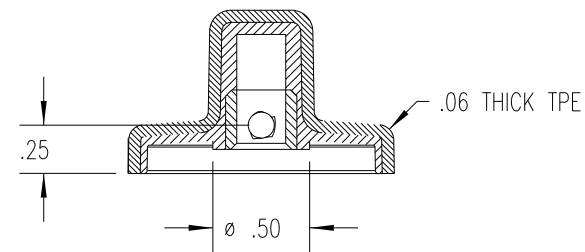
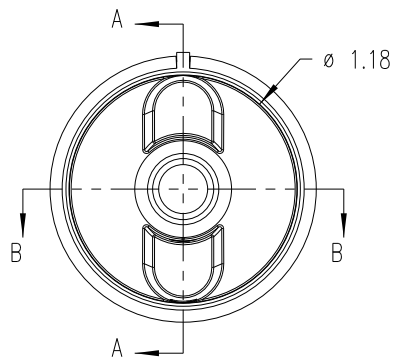

SECTION B-B

MATERIAL: SUBSTRATE: POLYPROPYLENE (CLD)  
OVERMOLD: TPE (TPE3)

COLOR: SUBSTRATE: BLACK (PC-301)  
OVERMOLD: BLACK (PC-301)

TOLERANCES: UNLESS OTHERWISE SPECIFIED	DO NOT SCALE DRAWING	B	ADDED BASE PART	JAM	3/10/14
DECIMALS: X.XXX ± .005 X.XX ± .015	MM: X.XX ± 0.15MM X.X ± 0.4MM	A	MOLD # WAS 1505	JAM	12/14/09
FRACTIONS ± 1/64	ANG. ± 1°	-	WAS SK1505-11	JAM	3/5/09
CHANGES					