

THIS DOCUMENT IS THE PROPERTY OF KEYSTONE ELECTRONICS CORP. AND SHALL NOT BE REPRODUCED, DISTRIBUTED OR USED AS A BASIS FOR MANUFACTURE WITHOUT PRIOR WRITTEN PERMISSION FROM KEYSTONE ELECTRONICS CORP.

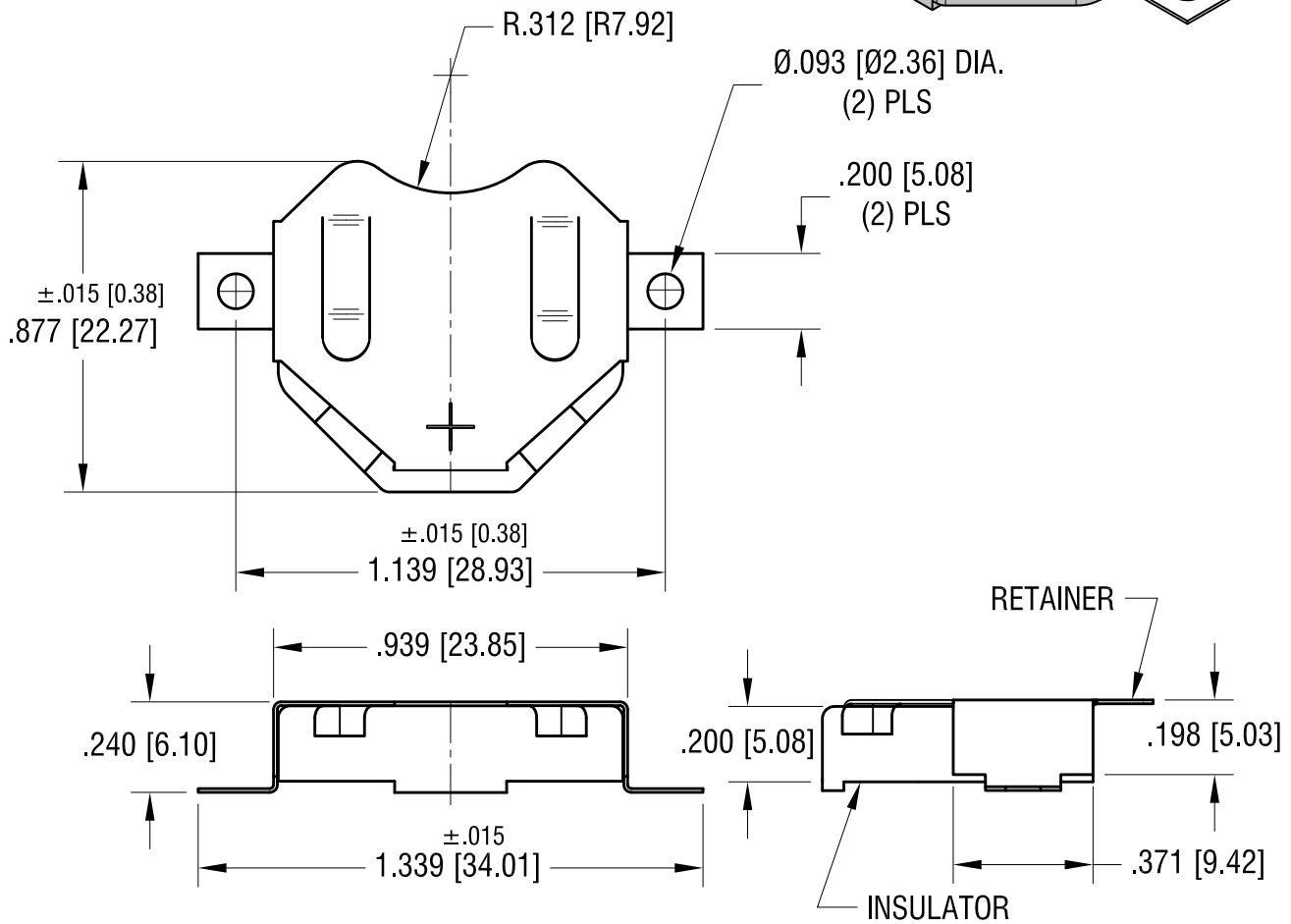
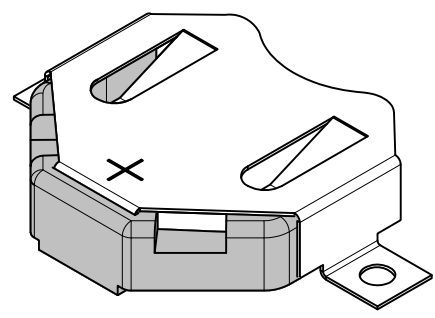
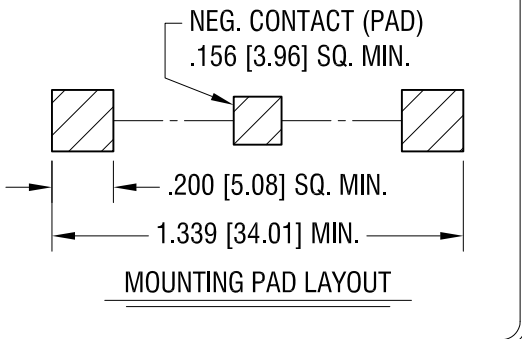

NOTE:

1. CLIP MAT'L: .010 TH'K FULL HARD PHOSPHOR BRONZE
INSULATOR MAT'L: HIGH TEMPERATURE NYLON, UL 94V-0
COLOR: WHITE
2. CLIP FINISH: TIN-NICKEL PLATE

KEYSTONE ELECTRONICS CORP.			
www.keyelco.com • ASTORIA, N.Y. 11105-2017 • Tel (718) 956-8900			
PART NAME			
SM COIN CELL CLIP FOR TWO 2020 OR 2025			
MATERIAL			
AS NOTED			
FINISH		DRN BY	DATE
AS NOTED		NT	11.17.09
		APP'D	SCALE
		LN	2X
TOLERANCES	INCH [MM]	CODE	DWG NO.
DECIMAL	± .010 [± 0.25]	C	3022
ANGULAR	± 1°		
UNLESS OTHERWISE SPECIFIED			

DATE	DESCRIPTION	REV.	
------	-------------	------	--