

---

## *3-Phase Sinusoidal Motor Controller*

---

### **Discontinued Product**

These parts are no longer in production. The device should not be purchased for new design applications. Samples are no longer available.

Date of status change: January 20, 2016

---

NOTE: For detailed information on purchasing options, contact your local Allegro field applications engineer or sales representative.

---

*Allegro MicroSystems, LLC reserves the right to make, from time to time, revisions to the anticipated product life cycle plan for a product to accommodate changes in production capabilities, alternative product availabilities, or market demand. The information included herein is believed to be accurate and reliable. However, Allegro MicroSystems, LLC assumes no responsibility for its use; nor for any infringements of patents or other rights of third parties which may result from its use.*

---

## 3-Phase Sinusoidal Motor Controller

### Features and Benefits

- Sinusoidal Drive Current
- Hall Element Inputs
- PWM Current Limiting
- Dead-time Protection
- FGO (Tach) Output
- Internal UVLO
- Thermal Shutdown Circuitry

### Description

Designed to control three-phase brushless DC motors, the A4923 is capable of high-current gate drive for an all N-channel power MOSFET 3-phase bridge.

Sinusoidal current control is employed via output PWM, to minimize vibration, noise, and torque ripple.

Internal circuit protection includes thermal shutdown with hysteresis, over-current, and dead-time protection. Special power up sequencing is not required.

The A4923 is supplied in a 32 terminal 5×5×0.9mm QFN package (suffix ET) with exposed pad for enhanced thermal dissipation. This small footprint package is lead (Pb) free with 100% matte tin leadframe plating, and it is also available with optional sidewall plating.

### Packages: 32-Pin QFN (suffix ET)

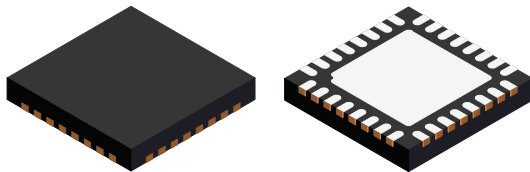

*Not to scale*

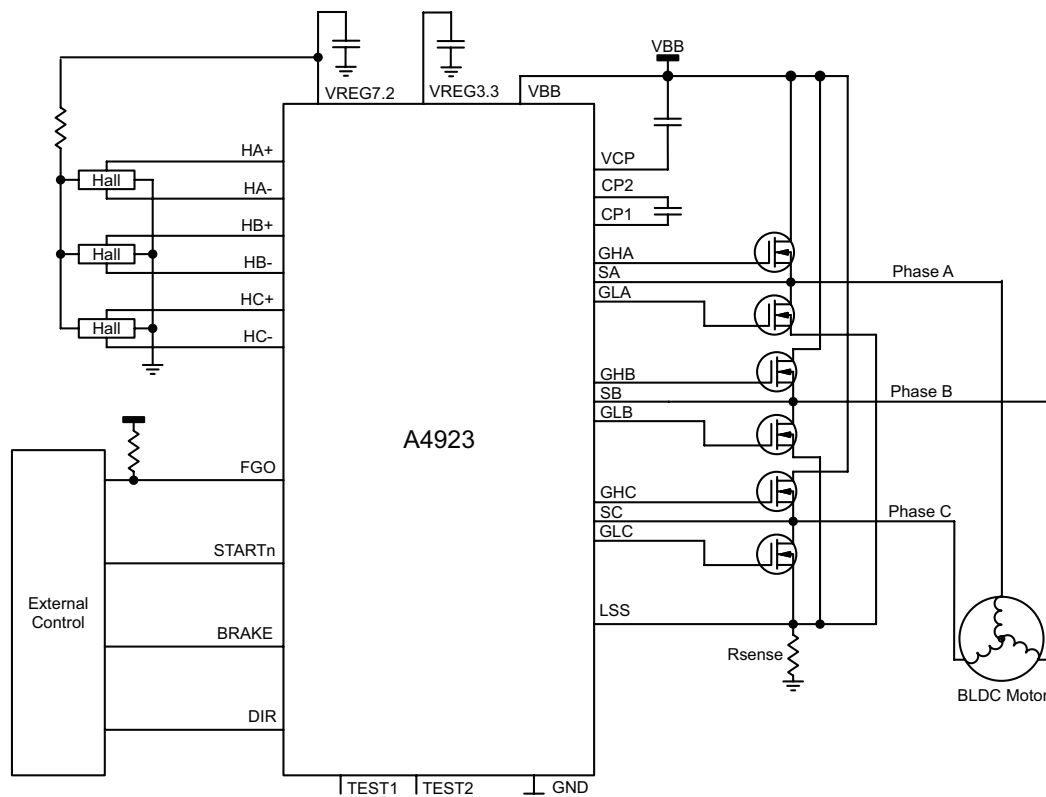

**Typical Application Diagram**

### Selection Guide

Part Number	Package	Packing	Sidewall Plating
A4923GETTR-T	5 mm X 5 mm, 0.90 mm nominal height QFN	1500 pieces per reel	No
A4923GETTR-R*	5 mm X 5 mm, 0.90 mm nominal height QFN	1500 pieces per reel	Yes

\*Contact factory for availability



### Absolute Maximum Ratings

Characteristic	Symbol	Notes	Rating	Unit
Supply Voltage	$V_{BB}$		36	V
Logic Input Voltage Range	$V_{IN}$		-0.3 to 6	V
Logic Outputs	$V_O$		6	V
Junction Temperature	$T_J$		150	°C
Operating Ambient Temperature Range	$T_A$	Range G	-40 to 105	°C
Storage Temperature Range	$T_{stg}$		-55 to 150	°C

**Thermal Characteristics** may require derating at maximum conditions, see application information

Characteristic	Symbol	Test Conditions*	Value	Unit
Package Thermal Resistance A4923GET	$R_{\theta JA}$	On 2-sided PCB, 1 in <sup>2</sup> copper	50	°C/W
		On 4-layer PCB	32	°C/W

\*Additional thermal information available on the Allegro website.

## Pin-out Diagrams

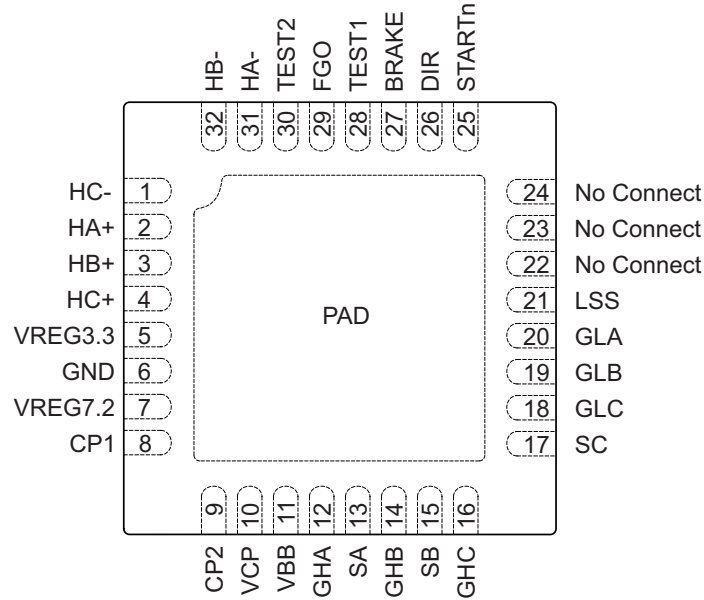

ET Package

### Terminal List Table

Name	Function	Number	Name	Function	Number
HC-	Analog hall input C	1	SC	High-side source connection C	17
HA+	Analog hall input A	2	GLC	Low-side gate drive C	18
HB+	Analog hall input B	3	GLB	Low-side gate drive B	19
HC+	Analog hall input C	4	GLA	Low-side gate drive A	20
VREG3.3	3.3V regulator capacitor terminal	5	LSS	Low-side sense resistor connection	21
GND	Ground	6	-	No connect	22
VREG7.2	7.2V regulator capacitor terminal	7	-	No connect	23
CP1	Charge pump capacitor terminal	8	-	No connect	24
CP2	Charge pump capacitor terminal	9	STARTn	Digital start input	25
VCP	Charge pump reservoir cap terminal	10	DIR	Digital direction input	26
VBB	Supply voltage	11	BRAKE	Digital brake input	27
GHA	High-side gate drive A	12	TEST1	ATE terminal, can be left open or connected to GND	28
SA	High-side source connection A	13	FGO	Digital motor-speed output	29
GHB	High-side gate drive B	14	TEST2	ATE terminal, can be left open or connected to GND	30
SB	High-side source connection B	15	HA-	Analog hall input A	31
GHC	High-side gate drive C	16	HB-	Analog hall input B	32
			PAD		-

**ELECTRICAL CHARACTERISTICS** Valid at  $T_A = 25^\circ\text{C}$ , unless otherwise specified

Characteristic	Symbol	Test Conditions	Min.	Typ.	Max.	Unit
<b>Supply and Reference</b>						
VBB Voltage Range	$V_{BB}$		10	–	32	V
VBB Supply Current	$I_{BB}$		–	18	22	mA
VREG3.3 Voltage	$V_{REG3.3}$	$I = 0$ to $-5$ mA	2.9	3.3	3.5	V
VREG7.2 Voltage	$V_{REG7.2}$	Gate Drive Supply, $I = 0$ to $-24$ mA	6.8	7.2	7.6	V
VREG7.2 Current Limit	$I_{LIMREG7.2}$		–30	–	–	mA
<b>Logic Inputs</b>						
<b>STARTn, DIR, BRAKE</b>						
Logic Input Low Level	$V_{IL}$		0	–	0.8	V
Logic Input High Level	$V_{IH}$		2.0	–	5.5	V
Logic Input Hysteresis	$V_{HYS}$		–	350	–	kHz
Logic Input Current	$R_{IN}$	Pull-up to internal 3.3V	34	47	60	$k\Omega$
	$I_{IN(1)}$	$V_{IN} = 5$ V	–	36	–	$\mu\text{A}$
	$I_{IN(0)}$	$V_{IN} = 0$ V	–	–70	–	$\mu\text{A}$
<b>Logic Outputs</b>						
<b>FGO</b>						
Output Saturation Voltage	$V_{SAT}$	$I = -7$ mA	–	0.14	0.21	V
Output Leakage	$I_{FGO}$	$V = 3.3$ V	–	–	1	$\mu\text{A}$
<b>Halls</b>						
Hall Input Current	$I_{HALL}$	$V_{IN} = 0.2$ V to $3.4$ V	–1	0	1	$\mu\text{A}$
Common Mode Input Range	$V_{CMR}$		0.2	–	3.4	V
AC Input Voltage Range	$V_{HALL}$		50	–	–	mVp-p
Hall Digital Filter Time	$t_{HALL}$		–	1.6	–	$\mu\text{s}$
<b>Gate Drive</b>						
PWM Carrier Frequency	$f_{PWM}$		19	20	21	kHz
Current Limit Input Threshold	$V_{LSS}$	Threshold on LSS terminal	216	240	256	mV
Gate Drive Output Voltage	$V_{GS}$	$I_{GATE} = -2$ mA	6.0	6.9	–	V
Gate Drive Source Current	$I_{GSR}$	$V_{GX} = 4$ V	–21	–30	–39	mA
Gate Drive Sink Current	$I_{GSNK}$	$V_{GX} = 4$ V	50	70	90	mA
Gate Pulldown, Passive	$R_{PULLDOWN}$		–	300	–	$k\Omega$
Dead Time	$t_{DEAD}$		1460	–	1880	$\mu\text{s}$
Fixed Off-time	$t_{OFF}$		21.0	–	27.5	$\mu\text{s}$
LSS Digital Filter Time	$t_{BLANK}$		720	–	880	$\mu\text{s}$
<b>Protection</b>						
Thermal Shutdown Temperature	$T_{JTSD}$		–	130	–	$^\circ\text{C}$
Thermal Shutdown Hysteresis	$\Delta T_{JTSD}$		–	10	–	$^\circ\text{C}$
VBB UVLO Threshold	$V_{UVLO}$	Rising $V_{BB}$	–	7.0	7.85	V
VBB UVLO Hysteresis	$V_{UVLOHYS}$		0.5	0.75	1.0	V

## NOTES:

1. Typical Data is for design information only.
2. Negative current is defined as coming out of (sourcing) the specified device terminal.
3. Specifications over operating temperature range are assured by design and characterization.

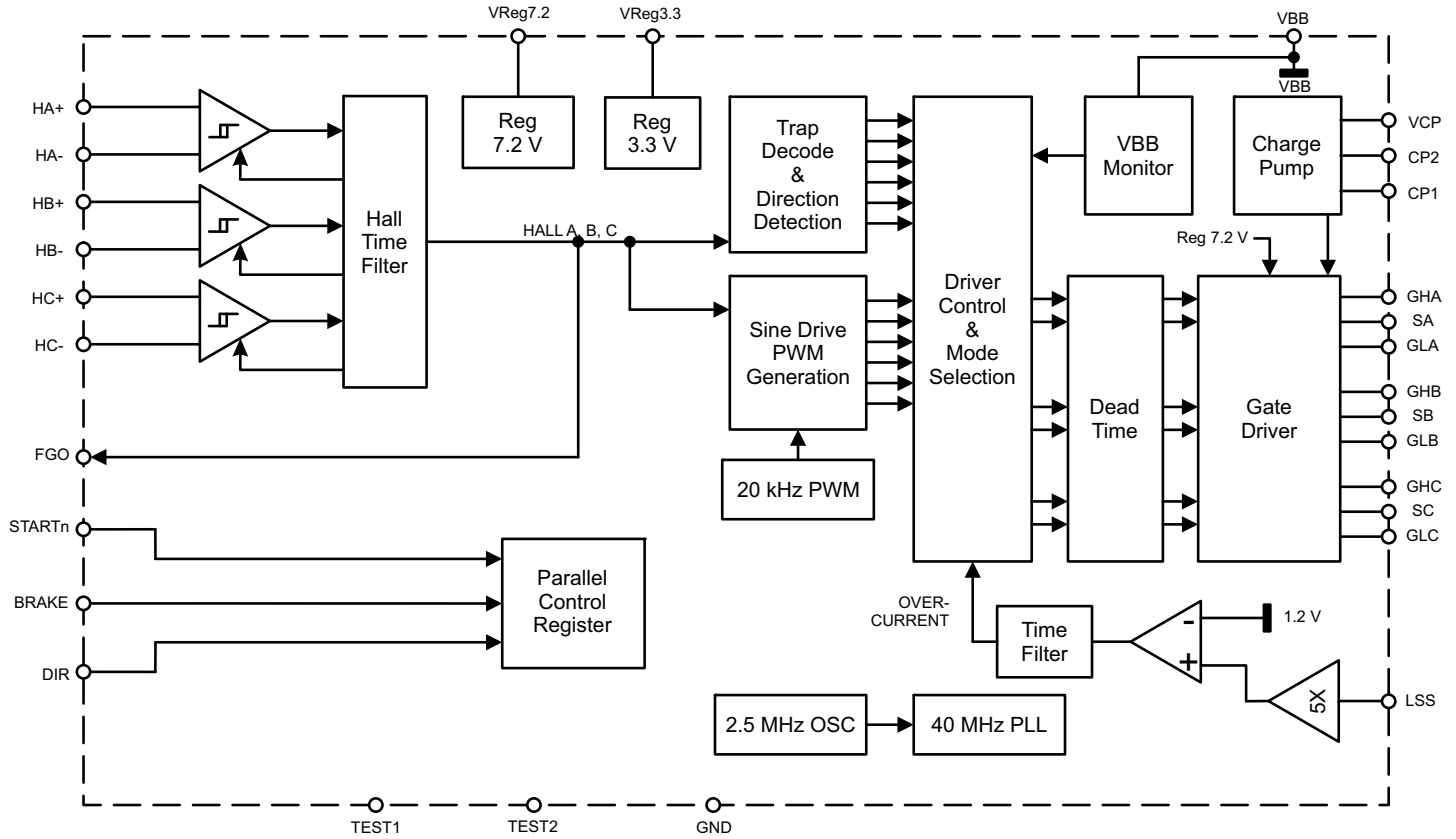

Functional Block Diagram

## Functional Description

### STARTn

The STARTn terminal is the active-low start/stop logic input. (low = start, high = all gate drive outputs off). Internally pulled up to VREG3.3.

### BRAKE

The BRAKE terminal is the active-high logic input to turn on all low-side MOSFETs. The STARTn terminal must be active (low) to enable brake. Internally pulled up to VREG3.3

### DIR

The DIR terminal is the logic input to control the motor's direction. A logic high = FWD and a logic low = REV. Internally pulled up to VREG3.3.

**Table 1:**

STARTn	BRAKEN	Fault	Function
H	X	L	All gate outputs low
L	L	L	Run
L	H	L	Brake
X	X	H	All gate outputs low

### FGO

The FGO terminal is an open-drain logic output which toggles state each hall transition.

### TEST1, TEST2

The TEST1 and TEST2 terminals are for ATE testing and can be left open or tied to GND.

### Current Limit

Over-current is controlled by an internal fixed off-time PWM control circuit. At the trip point, the sense comparator turns off

the enabled low-side driver, turns on the corresponding high side driver, and the motor current recirculates through the high-side drivers.

$$ITRIP = 240 \text{ mV} / R_{SENSE}$$

### Hall Inputs

Unique circuitry incorporates hysteresis which toggles polarity with the hall input slope direction. This allows the hall comparators to operate with very small offsets and results in highly symmetrical comparator outputs. A digital filter on the hall inputs minimizes sensitivity to noise.

### VPOS

A 0.1  $\mu\text{F}$  capacitor is required between this terminal and GND to stabilize the internal 3.3 V regulator

### VREG

A 0.1  $\mu\text{F}$  capacitor is required between this terminal and GND to stabilize the low-side gate supply.

### Charge Pump

Terminals CP1, CP2, and VCP generate a voltage above VBB that is used for the high-side gate supply. A 0.1  $\mu\text{F}$  capacitor is required between the CP1 and CP2 terminals, and between VCP and VBB.

### Fault

A fault occurs when VBB, the charge pump, or HBIAS falls below the respective UVLO threshold, the device temperature rises above  $T_J$ , or the hall inputs indicate an invalid state (111 or 000). The outputs are disabled in the event of a fault. Faults are not latched, and the device resumes operation once the fault is cleared.

**Sine Mode**

When the motor is stopped, a Hall Timeout error exists since the hall-transition timer has timed out. When a start signal is applied via the STARTn terminal, the motor is enabled in trapezoidal mode. When two consecutive hall transitions do not overflow the hall-transition timer, the Hall Timeout error is cleared and the drive switches to sinusoidal mode.

The sine modulation profile is stored in a digital look-up table. The sine modulation value is updated from the profile 192 times per electrical revolution. At each hall transition, which occurs every 60° or every 32 steps, the profile index is forced to the appropriate step. It is then advanced the successive 32 steps with a timer set internally using the previous hall transition period. The motor outputs are generated as follows (phase advance is not shown to simplify this diagram):

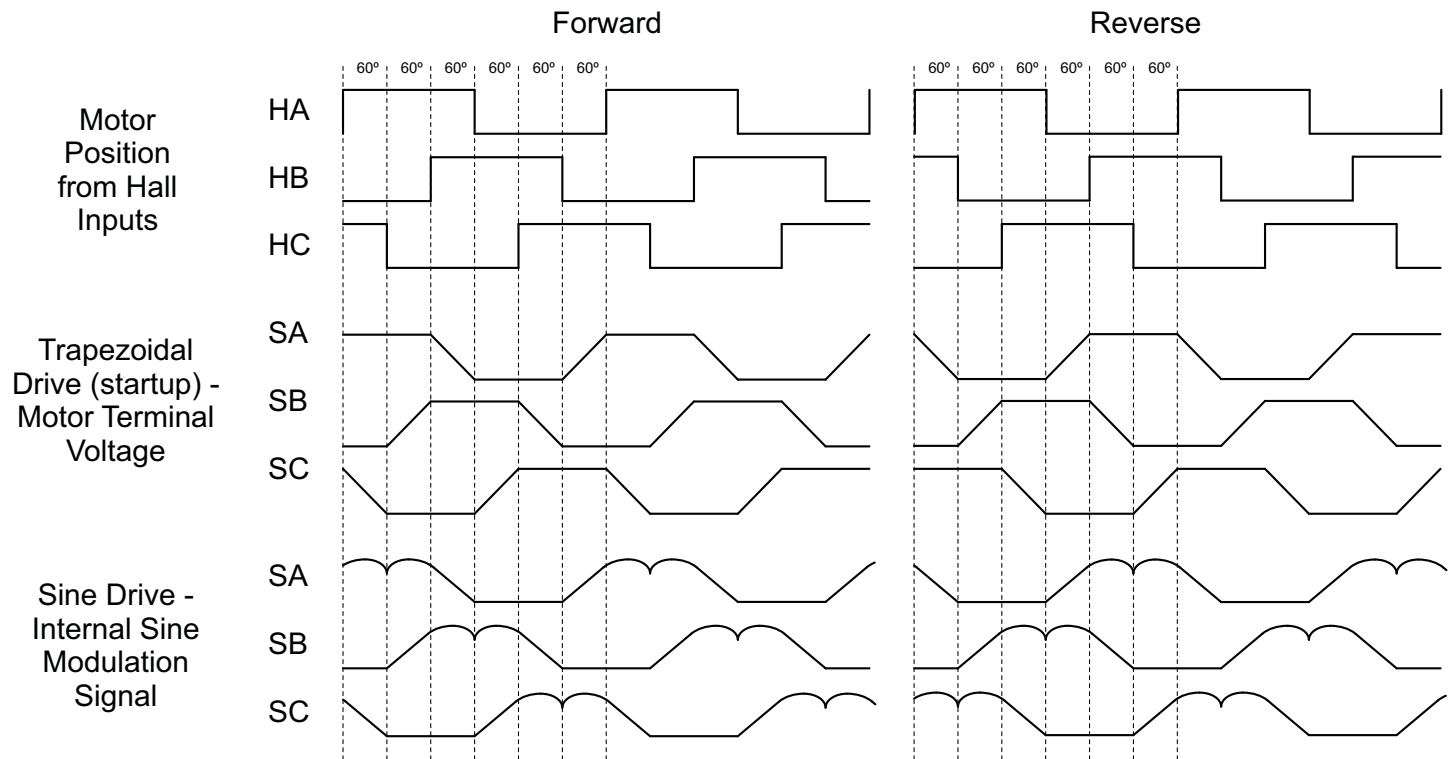

Figure 1: Motor Outputs



The internal sine modulation signal is converted to a PWM signal to drive the motor terminals. A 20 kHz carrier is modulated with the current sine profile value and used to generate the gate drive signals. Thus, the motor terminal voltage is a 20 kHz PWM signal with a duty cycle dependent upon the sine modulation signal. The high- and low-side gate drivers on a given motor terminal are

enabled inverted of the other, with a dead-time added to ensure both drivers will never be enabled at the same time. For increased efficiency, torque ripple, and audible noise, the sine profile is advanced 7.5° of one electrical revolution, relative to the hall transitions.

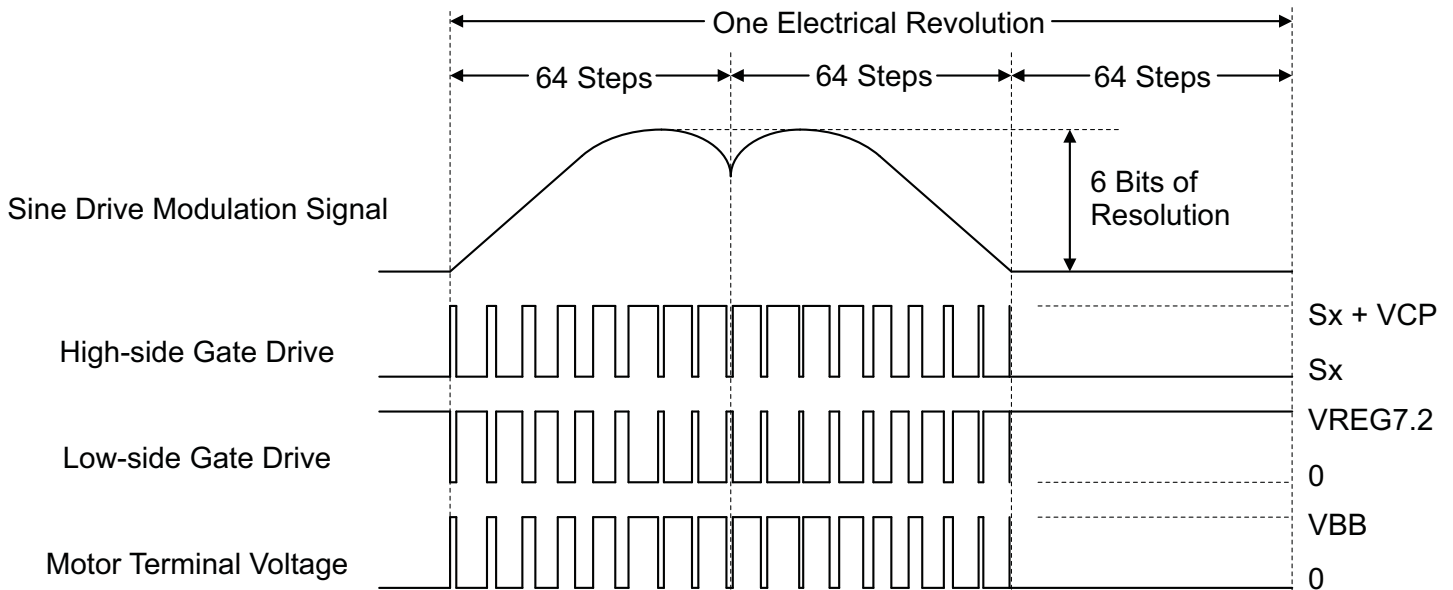
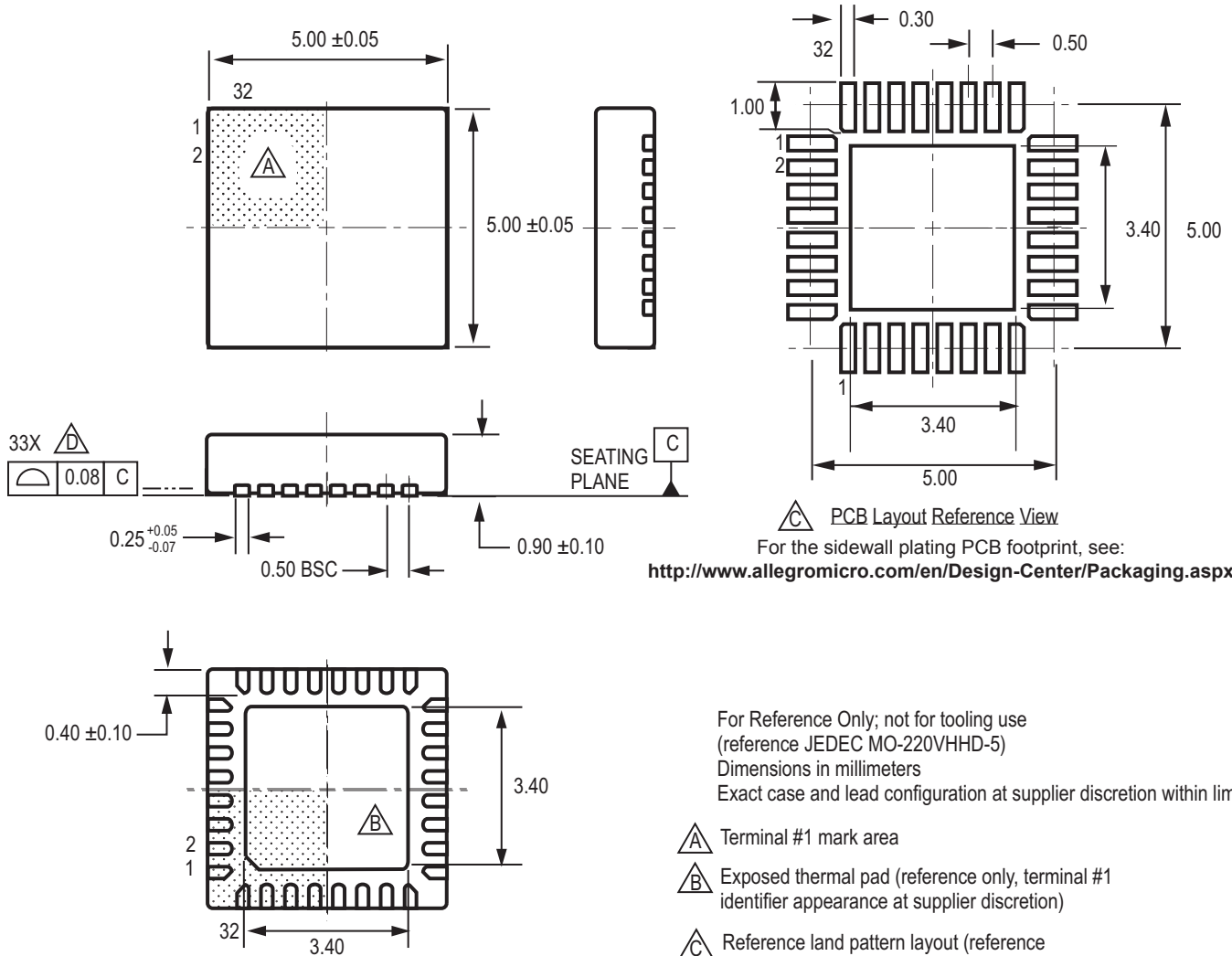

Figure 2: Sine Modulation Signal

Package ET, 32-Pin QFN  
with Exposed Thermal Pad



**C** PCB Layout Reference View

For the sidewall plating PCB footprint, see:

<http://www.allegromicro.com/en/Design-Center/Packaging.aspx>

For Reference Only; not for tooling use  
(reference JEDEC MO-220VHHD-5)

Dimensions in millimeters

Exact case and lead configuration at supplier discretion within limits shown

- A** Terminal #1 mark area
- B** Exposed thermal pad (reference only, terminal #1 identifier appearance at supplier discretion)
- C** Reference land pattern layout (reference IPC7351 QFN50P500X500X100-33V6M); All pads a minimum of 0.20 mm from all adjacent pads; adjust as necessary to meet application process requirements and PCB layout tolerances; when mounting on a multilayer PCB, thermal vias at the exposed thermal pad land can improve thermal dissipation (reference EIA/JEDEC Standard JESD51-5)

Copyright ©2012-2014, Allegro MicroSystems, LLC

Allegro MicroSystems, LLC reserves the right to make, from time to time, such departures from the detail specifications as may be required to permit improvements in the performance, reliability, or manufacturability of its products. Before placing an order, the user is cautioned to verify that the information being relied upon is current.

Allegro's products are not to be used in any devices or systems, including but not limited to life support devices or systems, in which a failure of Allegro's product can reasonably be expected to cause bodily harm.

The information included herein is believed to be accurate and reliable. However, Allegro MicroSystems, LLC assumes no responsibility for its use; nor for any infringement of patents or other rights of third parties which may result from its use.