

1 2 3 4 5 6 7 8

A
B
C
D
E
F

A
B
C
D
E
F

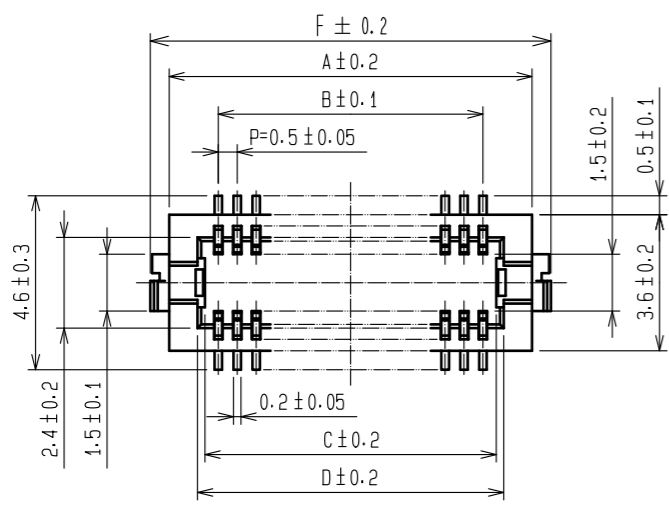

G-G (10:1)

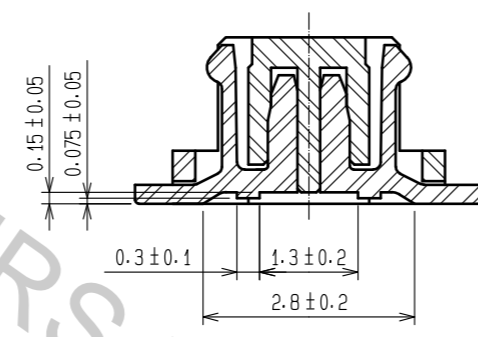

CODE No.	CONTACT	A	B	C	D	E	F
CL537-0651-6-86	10	4.6	2.0	2.7	3.1	2.8	5.6
CL537-0916-9-86	14	5.6	3.0	3.7	4.1	3.8	6.6
CL537-0653-1-86	20	7.1	4.5	5.2	5.6	5.3	8.1
CL537-0655-7-86	30	9.6	7.0	7.7	8.1	7.8	10.6
CL537-0662-2-86	32	10.1	7.5	8.2	8.6	8.3	11.1
CL537-0656-0-86	36	11.1	8.5	9.2	9.6	9.3	12.1
CL537-0657-2-86	40	12.1	9.5	10.2	10.6	10.3	13.1
CL537-0659-8-86	50	14.6	12.0	12.7	13.1	12.8	15.6
CL537-0661-0-86	60	17.1	14.5	15.2	15.6	15.3	18.1
CL537-0663-5-86	80	22.1	19.5	20.2	20.6	20.3	23.1

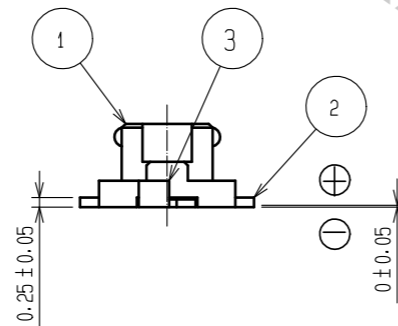
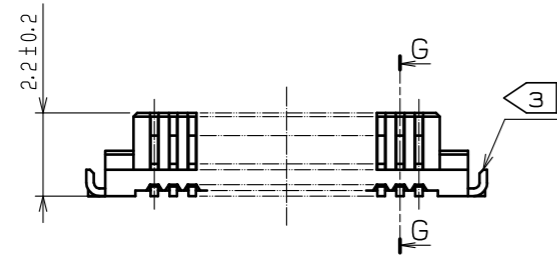

RECOMMEND METAL MASK PATTERN (10:1)

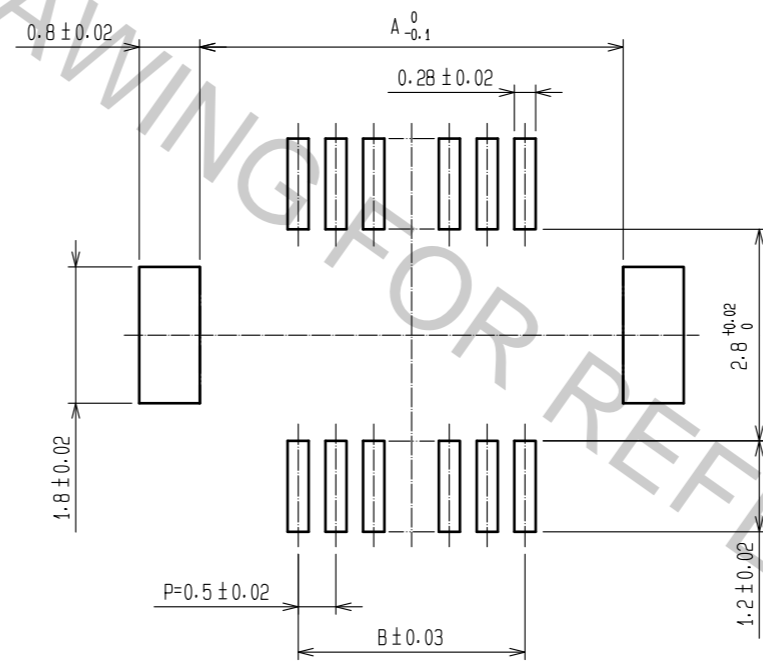

RECOMMENDED LAND PATTERN (10:1)

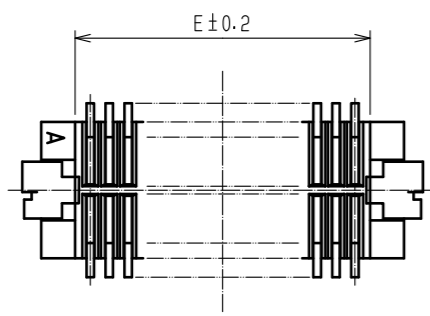
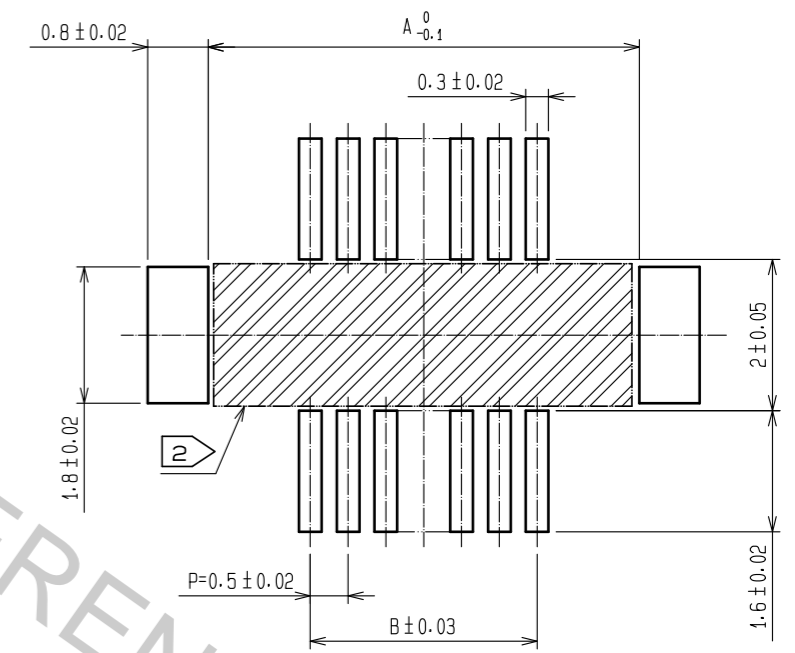

RECOMMENDED THICKNESS OF SOLDER PASTE : 120 μm

- NOTES 1 LEAD CO-PLANARITY SHALL BE 0.08 mm MAX.
 2 IF THERE IS PATTERN ON PART, THERE IS A POSSIBILITY THAT IT WILL MAKE CONTACT WITH THE LEADS.
 3 REINFORCED METAL FITTINGS AS FOLLOWS.

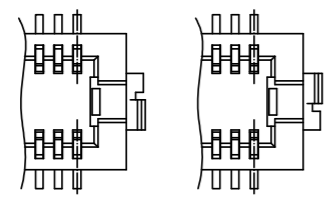

NO.	MATERIAL	FINISH .	REMARKS	NO.	MATERIAL	FINISH .	REMARKS
2	PHOSPHOR BRONZE		CONTACT AREA:GOLD PLATED 0.2μm min LEAD AREA:GOLD PLATED 0.015μm min OTHERS(UNDER PLATING):NICKEL PLATED 2μm min	7	PS		CLEAR (REINFORCEMENT COLLAR)
1	POLYAMIDE		UL94V-0, NATURAL (BEIGE)	6	PS		BLACK (PLASTIC REEL)
				5	POLYESTER		CLEAR (COVER TAPE)
				4	PS		CLEAR (EMBOSSED CARRIER TAPE)
				3	BRASS		TIN PLATED 2μm min (UNDER PLATING):NICKEL 1μm min

UNITS	SCALE	COUNT	DESCRIPTION OF REVISIONS	DESIGNED	CHECKED	DATE
mm	5 : 1	1	DIS-H-00001678	SH. HOSODA	TS. MIYAZAKI	16.05.30

APPROVED	: KH. IKEDA	13.08.06	DRAWING NO.	EDC3-160764-77	
CHECKED	: YH. MICHIDA	13.08.05	PART NO.	DF12B(3.0)-*DS-0.5V(86)	
DESIGNED	: YN. SAKAMOTO	13.08.05	CODE NO.	CL537	
DRAWN	: KR. AJITO	13.08.05			

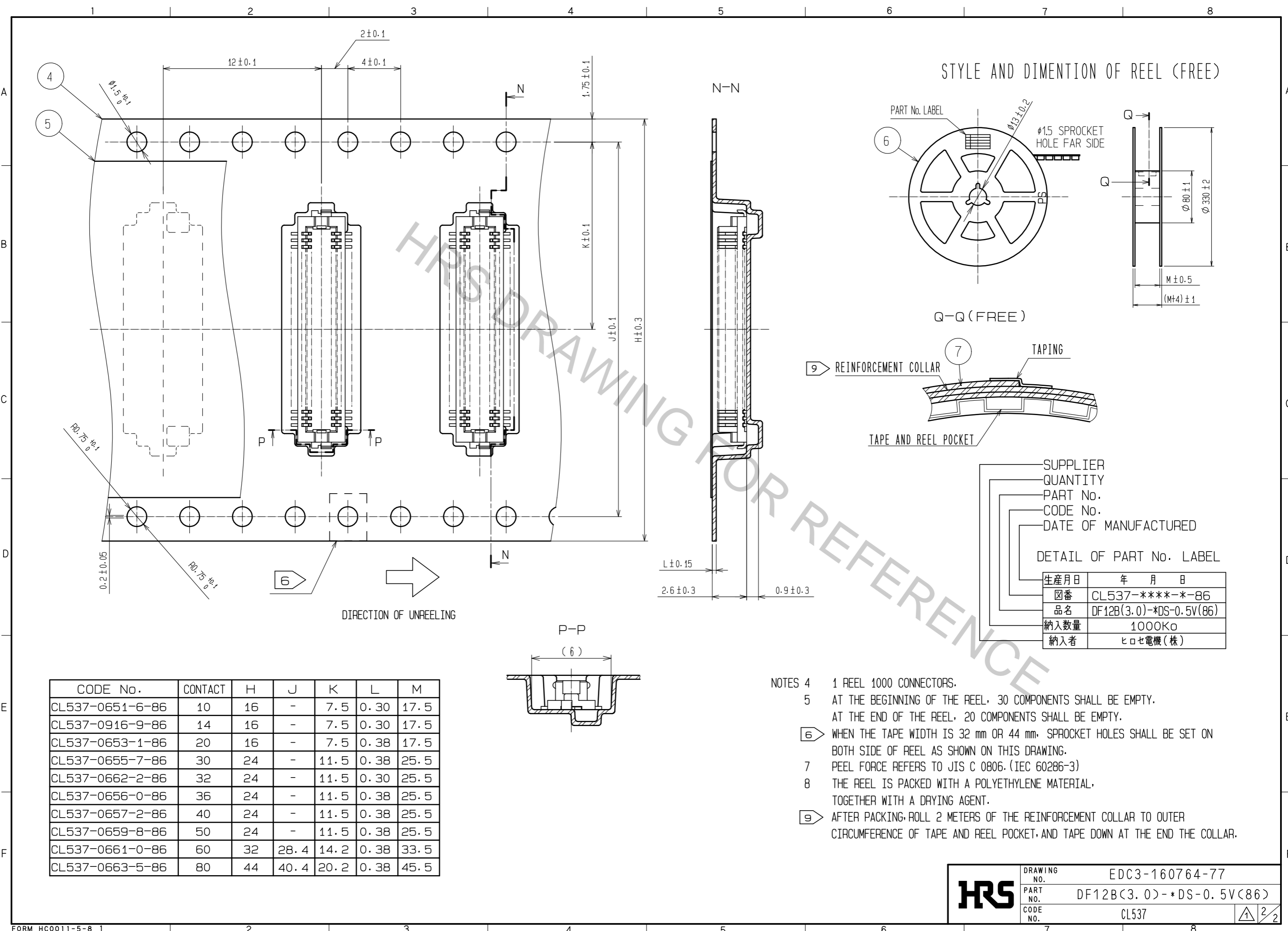

STYLE AND DIMENTION OF REEL (FREE)

SUPPLIER
QUANTITY
PART No.
CODE No.
DATE OF MANUFACTURED

DETAIL OF PART No. LABEL

生産月日	年 月 日
図番	CL537-****-*-86
品名	DF12B(3.0)-*DS-0.5V(86)
納入数量	1000K ϕ
納入者	ヒロセ電機(株)

CODE No.	CONTACT	H	J	K	L	M
CL537-0651-6-86	10	16	-	7.5	0.30	17.5
CL537-0916-9-86	14	16	-	7.5	0.30	17.5
CL537-0653-1-86	20	16	-	7.5	0.38	17.5
CL537-0655-7-86	30	24	-	11.5	0.38	25.5
CL537-0662-2-86	32	24	-	11.5	0.30	25.5
CL537-0656-0-86	36	24	-	11.5	0.38	25.5
CL537-0657-2-86	40	24	-	11.5	0.38	25.5
CL537-0659-8-86	50	24	-	11.5	0.38	25.5
CL537-0661-0-86	60	32	28.4	14.2	0.38	33.5
CL537-0663-5-86	80	44	40.4	20.2	0.38	45.5

- NOTES
- 4 1 REEL 1000 CONNECTORS.
 - 5 AT THE BEGINNING OF THE REEL, 30 COMPONENTS SHALL BE EMPTY.
AT THE END OF THE REEL, 20 COMPONENTS SHALL BE EMPTY.
 - 6 WHEN THE TAPE WIDTH IS 32 mm OR 44 mm, SPROCKET HOLES SHALL BE SET ON BOTH SIDE OF REEL AS SHOWN ON THIS DRAWING.
 - 7 PEEL FORCE REFERS TO JIS C 0806. (IEC 60286-3)
 - 8 THE REEL IS PACKED WITH A POLYETHYLENE MATERIAL, TOGETHER WITH A DRYING AGENT.
 - 9 AFTER PACKING, ROLL 2 METERS OF THE REINFORCEMENT COLLAR TO OUTER CIRCUMFERE OF TAPE AND REEL POCKET, AND TAPE DOWN AT THE END THE COLLAR.

HRS

DRAWING NO.	EDC3-160764-77
PART NO.	DF12B(3.0)-*DS-0.5V(86)
CODE NO.	CL537

2/2