



# MAX9937 Evaluation Kit

Evaluates: MAX9937

## General Description

The MAX9937 evaluation kit (EV kit) is an assembled and tested PCB used to evaluate the MAX9937 automotive grade current-sense amplifier, designed for unidirectional high-side current-sense applications. The EV kit can be used to demonstrate the applicability of the MAX9937 to withstand automotive transients, such as load-dump protection, reverse-battery protection, and filtering for EMI.

## Component List

DESIGNATION	QTY	DESCRIPTION
C1	1	1 $\mu$ F $\pm$ 10%, 50V X7R ceramic capacitor (1206) Murata GRM31MR71H105KA TDK C3216X7R1H105K
C2, C4	0	Not installed, capacitors (0603)
C3	1	0.01 $\mu$ F $\pm$ 10%, 50V X7R ceramic capacitor (0603) Murata GRM188R71H103K TDK C1608X7R1H103K
R1	1	0.05 $\Omega$ $\pm$ 1%, 0.5W current-sense resistor (1206) IRC LRC-LR1206LF-01-R050-F
R2	1	20k $\Omega$ $\pm$ 1% resistor (0603)
R3, R4	2	1k $\Omega$ $\pm$ 1% resistor (1206)
U1	1	Automotive grade current-sense amplifier (5 SC70) Maxim MAX9937AXK+
—	1	PCB: MAX9937 Evaluation Kit+

## Component Suppliers

SUPPLIER	PHONE	WEBSITE
IRC, Inc.	361-992-7900	www.irctt.com
Murata Electronics North America, Inc.	770-436-1300	www.murata-northamerica.com
TDK Corp.	847-803-6100	www.component.tdk.com

**Note:** Indicate that you are using the MAX9937 when contacting these component suppliers.

## Features

- ◆ Reverse-Battery and Load-Dump Protection  
-20V to +40V
- ◆ +4V to +28V Input Common-Mode Range
- ◆ +2.7V to +5.5V Supply Range
- ◆ Flexible EMI Filtering
- ◆ Lead(Pb)-Free and RoHS Compliant
- ◆ Fully Assembled and Tested

## Ordering Information

PART	TYPE
MAX9937EVKIT+	EV Kit

+Denotes lead(Pb)-free and RoHS compliant.

## Quick Start

### Recommended Equipment

Before beginning, the following equipment is needed:

- 12V, 2A power supply (VBAT)
- 5V power supply (VCC)
- Electronic load capable of sinking 2A
- Digital voltmeter (DVM)

### Procedure

The MAX9937 EV kit is fully assembled and tested. Follow the steps below to verify board operation.

**Caution: Do not turn on power supplies until all connections are completed.**

- 1) Set the input power supply to 12V and connect the positive terminal to the VBAT pad. Connect the ground of the power supply to the GND pad.
- 2) Set the VCC power supply to 5V and connect the positive terminal to the VCC pad. Connect the ground of the VCC supply to the GND pad.
- 3) Set the electronic load to sink 2A.
- 4) Connect the electronic load's positive terminal to the LOAD pad. Connect the load's ground to the GND pad.
- 5) Connect the DVM across the VOUT pad and the GND pad.
- 6) Turn on the 5V power supply.

## MAX9937 Evaluation Kit

- 7) Turn on the 12V power supply.
- 8) Adjust the electronic load current ( $I_{LOAD}$ ) between 0A and 2A and verify that  $V_{OUT}$  is proportional to  $V_{SENSE}$  according to the following equation:

$$V_{OUT} = V_{SENSE} \times \frac{R2}{R3}$$

where  $V_{SENSE} = I_{LOAD} \times R1$ .

### **\_\_Detailed Description of Hardware**

The MAX9937 EV kit evaluates the MAX9937 unidirectional high-side current-sense amplifier, which features a 4V to 28V input common-mode voltage range that is independent of supply voltage ( $VCC = 2.7V$  to  $5.5V$ ). The MAX9937 monitors the current through a current-sense resistor by converting the sense voltage to a voltage output ( $V_{OUT}$ ). Gain is set by the ratio of an output resistor ( $R2$ ) and an input resistor ( $R3$ ). High-side current monitoring with the MAX9937 does not interfere with the ground path of the load, making it useful for a variety of automotive battery/ECU monitoring applications.

The MAX9937 EV kit produces an output voltage ( $V_{OUT}$ ) given by the following equations:

$$V_{SENSE} = I_{LOAD} \times R_{SENSE}$$

$$V_{OUT} = V_{SENSE} \times \frac{R2}{R3}$$

where  $I_{LOAD}$  is the current load applied to the device and  $R_{SENSE}$  is the current-sense resistor  $R1$  (e.g.,  $I_{LOAD} = 2A$ ,  $R_{SENSE} = 0.05\Omega$ ,  $R2 = 20k\Omega$ ,  $R3 = 1k\Omega$ , and  $V_{OUT} = 2V$ ).

### **Overvoltage Protection**

The MAX9937 EV kit provides a  $1k\Omega$  resistor at each of the RSP and RSN inputs to demonstrate the reverse-battery and load-dump protection capabilities of the MAX9937 IC. The normal operating  $V_{RSP}$  and  $V_{RSN}$  range is 4V to 28V, but the robust input ESD structure allows the input common-mode voltages to exceed this range for short periods of time.

Short-duration overvoltages on the battery line ( $V_{BAT}$  to  $LOAD$ ) are isolated from the RSP and RSN pins of the MAX9937 by the use of input resistors  $R3$  and  $R4$ . The input ESD clamp structure is designed so the device can withstand short-duration ( $< 1s$ ) overvoltages up to 40V when using resistors  $R3$  and  $R4$  of  $500\Omega$  or greater. The circuit can also withstand a reverse-battery voltage of  $-20V$ . During reverse-battery conditions, size  $R3$  and  $R4$  input resistors to withstand their expected power dissipations. Refer to the *Input Common-Mode Voltages > 28V and < 0V* section in the MAX9937 IC data sheet for a more detailed description.

### **EMI Filtering**

The MAX9937 EV kit provides two uninstalled capacitor pads ( $C2$  and  $C4$ ), which the user can populate to improve performance in the presence of input common-mode voltage and input differential-voltage transients. Refer to the *Flexible EMI Filtering* section in the MAX9937 IC data sheet for a more detailed description.

# MAX9937 Evaluation Kit

Evaluates: MAX9937

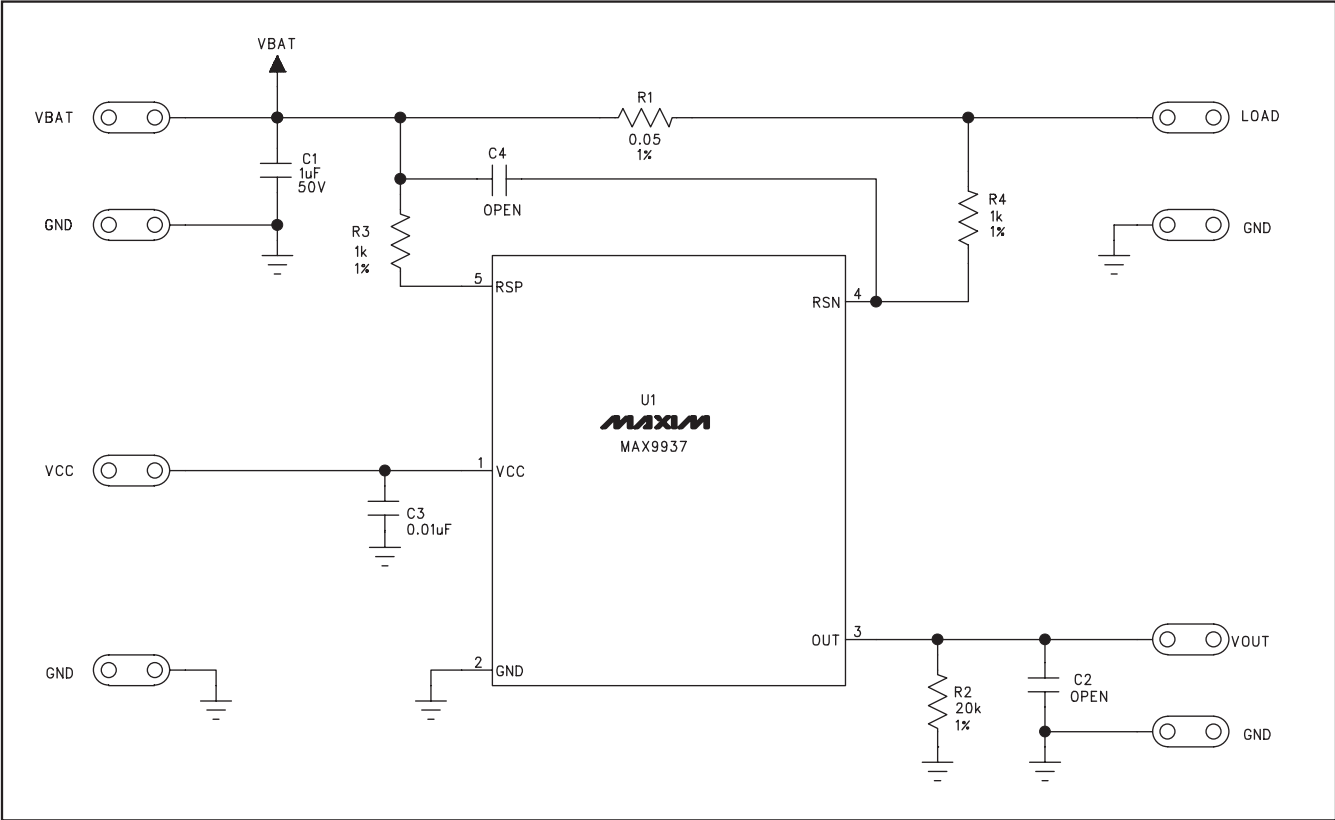

Figure 1. MAX9937 EV Kit Schematic

# MAX9937 Evaluation Kit

Evaluates: MAX9937

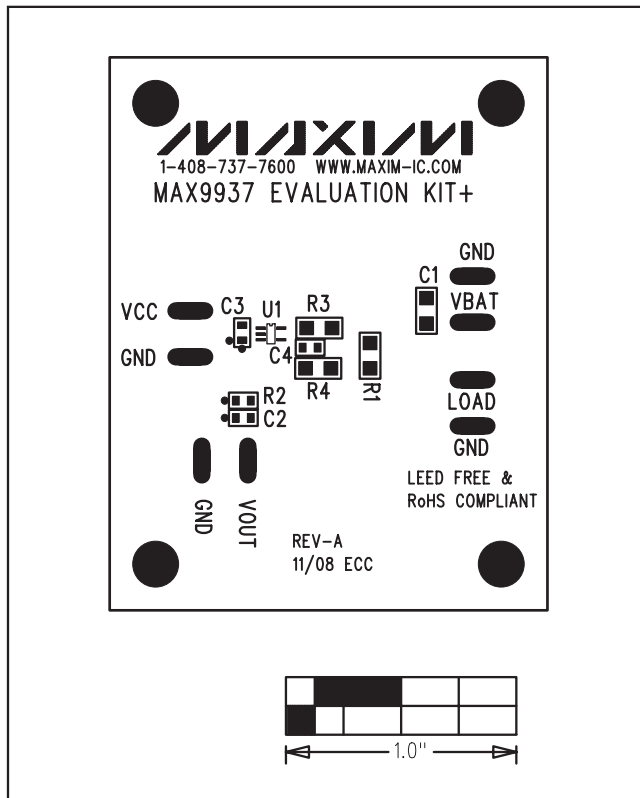

Figure 2. MAX9937 EV Kit Component Placement Guide—Component Side

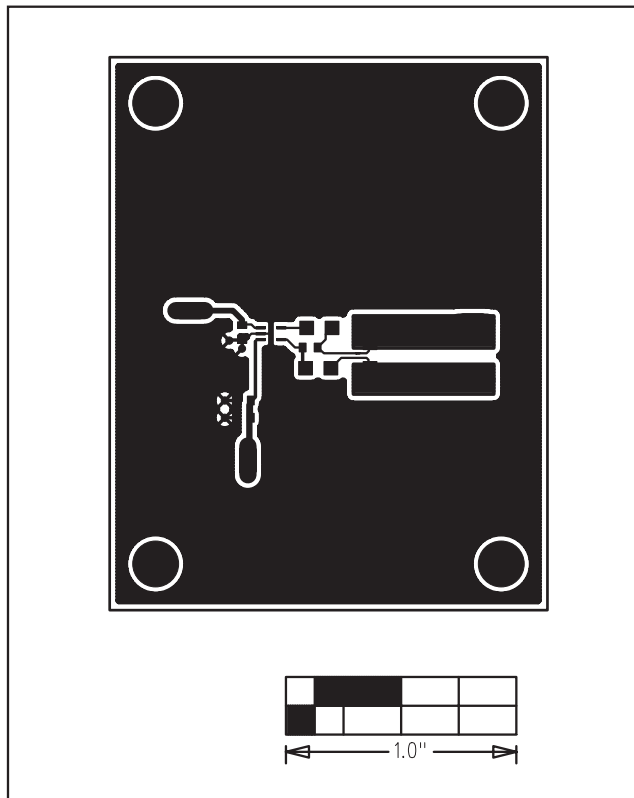

Figure 3. MAX9937 EV Kit Component PCB Layout—Component Side

# MAX9937 Evaluation Kit

Evaluates: MAX9937

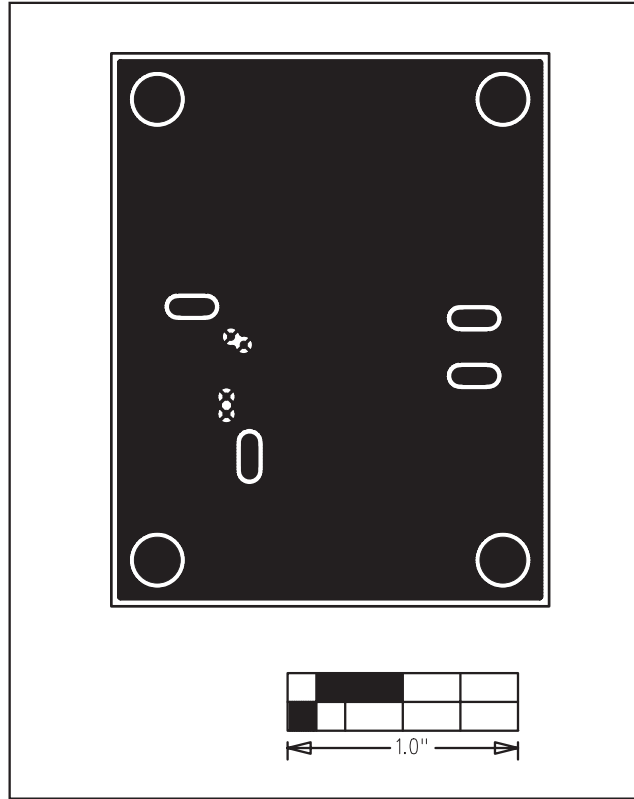

Figure 4. MAX9937 EV Kit PCB Layout—Solder Side

Maxim cannot assume responsibility for use of any circuitry other than circuitry entirely embodied in a Maxim product. No circuit patent licenses are implied. Maxim reserves the right to change the circuitry and specifications without notice at any time.

**Maxim Integrated Products, 120 San Gabriel Drive, Sunnyvale, CA 94086 408-737-7600** \_\_\_\_\_ **5**