

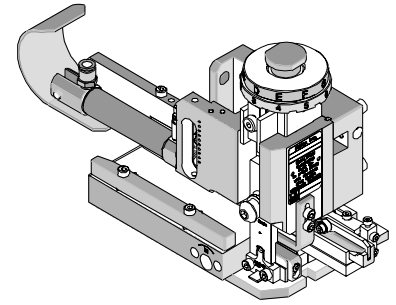

## Mini-Mac Applicator Application Tooling Specification Air Feed-Mylar Tape Part No. 63885-8100



### FEATURES

- Directly adapts to most crimp presses and automatic wire processors
- Applicator designed to industry-standard mounting and shut height of 135.80mm (5.346")
- Conductor and insulation rings allow quick adjustment for conductor and insulation crimp height change
- Quick set-up time; plus the crimp height, track and feed adjustments can be set without removing the applicator from the crimp press

### SCOPE

Products: Krimptite®/Versakrimp® Ring, Spade, Rectangular, Hook Tongue Terminals, And Butt Splices 14-16 AWG.

#### Testing

##### Mechanical

The tensile test, or pull test, is a means of evaluating the mechanical properties of the crimped connections. The following chart shows the UL and government specifications (MIL-T-7928) for various wire sizes. The tensile strength is shown in pounds and indicates the minimum acceptable force to break or separate the terminal from the conductor.

Color Code	Wire Size (AWG)	*UL - 486 A	*UL - 486 C	*UL - 310	*Military Class 2
Yellow	26	3	N/A	N/A	7
Yellow	24	5	N/A	N/A	10
Red	22	8	8	8	15
Red	20	13	10	13	19
Red	18	20	10	20	38
Blue	16	30	15	30	50
Blue	14	50	25	50	70
Yellow	12	70	35	70	110
Yellow	10	80	40	80	150
Red	8	90	45	N/A	225
Blue	6	100	50	N/A	300

\*UL - 486 A - Terminals (Copper conductors only)

\*UL - 486 C - Butt Splices, Parallel Splices, Closed End Connectors, and Wire Nuts

\*UL - 310 - Quick Disconnects, Flag and Couplers

\*Military Class 2- Military Approved Terminals only as listed

### Product List

The following is a partial list of the product order numbers and their specifications that this tool is designed to run. Updates to this list are available on [www.molex.com](http://www.molex.com).

Terminal No.	Terminal Eng. No.	Wire Size		Insulation Diameter Max.		Strip Length	
		AWG	mm <sup>2</sup>	mm	In.	mm	In.
19033-0006	B-179T	14-16	2.00-1.30	N/A	N/A	7.14	.281
19033-0008	B-189T	14-16	2.00-1.30	N/A	N/A	7.14	.281
19044-0015	B-118-10T	14-16	2.00-1.30	N/A	N/A	7.14	.281
19044-0017	B-123-02T	14-16	2.00-1.30	N/A	N/A	7.14	.281
19044-0018	B-125-56T	14-16	2.00-1.30	N/A	N/A	7.14	.281
19044-0029	B-137-04T	14-16	2.00-1.30	N/A	N/A	7.14	.281
19044-0034	B-139-04T	14-16	2.00-1.30	N/A	N/A	7.14	.281
19044-0036	B-139-06T	14-16	2.00-1.30	N/A	N/A	7.14	.281
19044-0038	B-139-08T	14-16	2.00-1.30	N/A	N/A	7.14	.281
19044-0151	B-123-04T	14-16	2.00-1.30	N/A	N/A	7.14	.281
19044-0153	B-123-06T	14-16	2.00-1.30	N/A	N/A	7.14	.281
19044-0155	B-123-08T	14-16	2.00-1.30	N/A	N/A	7.14	.281
19044-0157	B-125-10T	14-16	2.00-1.30	N/A	N/A	7.14	.281
19044-0159	B-125-14T	14-16	2.00-1.30	N/A	N/A	7.14	.281
19044-0175	B-137-06T	14-16	2.00-1.30	N/A	N/A	7.14	.281
19044-0176	B-137-08T	14-16	2.00-1.30	N/A	N/A	7.14	.281
19044-0177	B-137-10T	14-16	2.00-1.30	N/A	N/A	7.14	.281
19044-0178	B-139-10T	14-16	2.00-1.30	N/A	N/A	7.14	.281
19056-0054	B-318-10T	14-16	2.00-1.30	N/A	N/A	7.14	.281
19056-0056	B-318-14T	14-16	2.00-1.30	N/A	N/A	7.14	.281
19056-0058	B-318-38T	14-16	2.00-1.30	N/A	N/A	7.14	.281
19056-0060	B-318-56T	14-16	2.00-1.30	N/A	N/A	7.14	.281
19056-0062	B-323-02T	14-16	2.00-1.30	N/A	N/A	7.14	.281
19056-0064	B-323-04T	14-16	2.00-1.30	N/A	N/A	7.14	.281
19056-0067	B-323-06T	14-16	2.00-1.30	N/A	N/A	7.14	.281
19056-0069	B-323-08T	14-16	2.00-1.30	N/A	N/A	7.14	.281
19056-0071	B-325-10T	14-16	2.00-1.30	N/A	N/A	7.14	.281
19056-0074	B-325-14T	14-16	2.00-1.30	N/A	N/A	7.14	.281
19056-0076	B-325-56T	14-16	2.00-1.30	N/A	N/A	7.14	.281
19079-0009	B-1006-MST	14-16	2.00-1.30	N/A	N/A	7.14	.281
19086-0067	B-108-06T	14-16	2.00-1.30	N/A	N/A	7.14	.281
19086-0119	B-108-04T	14-16	2.00-1.30	N/A	N/A	7.14	.281
19086-0120	B-108-08T	14-16	2.00-1.30	N/A	N/A	7.14	.281
19086-0121	B-109-06T	14-16	2.00-1.30	N/A	N/A	7.14	.281
19086-0122	B-109-08T	14-16	2.00-1.30	N/A	N/A	7.14	.281
19086-0123	B-109-10T	14-16	2.00-1.30	N/A	N/A	7.14	.281
19086-0124	B-113-04T	14-16	2.00-1.30	N/A	N/A	7.14	.281
19086-0125	B-113-06T	14-16	2.00-1.30	N/A	N/A	7.14	.281
19086-0126	B-113-08T	14-16	2.00-1.30	N/A	N/A	7.14	.281
19086-0127	B-182-06T	14-16	2.00-1.30	N/A	N/A	7.14	.281
19086-0128	B-182-08T	14-16	2.00-1.30	N/A	N/A	7.14	.281
19086-0129	B-182-10T	14-16	2.00-1.30	N/A	N/A	7.14	.281
19086-0130	B-185-06T	14-16	2.00-1.30	N/A	N/A	7.14	.281
19086-0131	B-185-08T	14-16	2.00-1.30	N/A	N/A	7.14	.281
19086-0132	B-185-10T	14-16	2.00-1.30	N/A	N/A	7.14	.281
19086-0133	B-188-04T	14-16	2.00-1.30	N/A	N/A	7.14	.281
19086-0134	B-188-06T	14-16	2.00-1.30	N/A	N/A	7.14	.281
19086-0135	B-188-08T	14-16	2.00-1.30	N/A	N/A	7.14	.281
19086-0136	B-188-10T	14-16	2.00-1.30	N/A	N/A	7.14	.281
19088-0062	B-308-04T	14-16	2.00-1.30	N/A	N/A	7.14	.281
19088-0063	B-308-06T	14-16	2.00-1.30	N/A	N/A	7.14	.281
19088-0064	B-309-06T	14-16	2.00-1.30	N/A	N/A	7.14	.281
19088-0065	B-309-08T	14-16	2.00-1.30	N/A	N/A	7.14	.281
19088-0066	B-309-10T	14-16	2.00-1.30	N/A	N/A	7.14	.281
19088-0067	B-313-04T	14-16	2.00-1.30	N/A	N/A	7.14	.281

Terminal No.	Terminal Eng. No.	Wire Size		Insulation Diameter Max.		Strip Length	
		AWG	mm <sup>2</sup>	mm	In.	mm	In.
19088-0068	B-313-06T	14-16	2.00-1.30	N/A	N/A	7.14	.281
19088-0069	B-313-08T	14-16	2.00-1.30	N/A	N/A	7.14	.281
19117-0049	B-116-06T	14-16	2.00-1.30	N/A	N/A	7.14	.281
19117-0051	B-116-08T	14-16	2.00-1.30	N/A	N/A	7.14	.281
19117-0067	B-183-10T	14-16	2.00-1.30	N/A	N/A	7.14	.281
19117-0082	B-116-04T	14-16	2.00-1.30	N/A	N/A	7.14	.281
19117-0085	B-116-10T	14-16	2.00-1.30	N/A	N/A	7.14	.281
19117-0088	B-180-06T	14-16	2.00-1.30	N/A	N/A	7.14	.281
19117-0089	B-180-08T	14-16	2.00-1.30	N/A	N/A	7.14	.281
19117-0090	B-180-10T	14-16	2.00-1.30	N/A	N/A	7.14	.281
19117-0091	B-183-06T	14-16	2.00-1.30	N/A	N/A	7.14	.281
19117-0092	B-183-08T	14-16	2.00-1.30	N/A	N/A	7.14	.281
19117-0093	B-186-04T	14-16	2.00-1.30	N/A	N/A	7.14	.281
19117-0094	B-186-06T	14-16	2.00-1.30	N/A	N/A	7.14	.281
19117-0095	B-186-08T	14-16	2.00-1.30	N/A	N/A	7.14	.281
19123-0052	B-316-04T	14-16	2.00-1.30	N/A	N/A	7.14	.281
19123-0053	B-316-06T	14-16	2.00-1.30	N/A	N/A	7.14	.281
19123-0054	B-316-08T	14-16	2.00-1.30	N/A	N/A	7.14	.281
19123-0055	B-316-10T	14-16	2.00-1.30	N/A	N/A	7.14	.281
19128-0015	B-1471-04T	14-16	2.00-1.30	N/A	N/A	7.14	.281
19128-0017	B-1471-06T	14-16	2.00-1.30	N/A	N/A	7.14	.281
19128-0018	B-1491-06T	14-16	2.00-1.30	N/A	N/A	7.14	.281
19128-0019	B-1491-08T	14-16	2.00-1.30	N/A	N/A	7.14	.281
19128-0020	B-1491-10T	14-16	2.00-1.30	N/A	N/A	7.14	.281
19128-0022	B-1781-06T	14-16	2.00-1.30	N/A	N/A	7.14	.281
19128-0024	B-1781-08T	14-16	2.00-1.30	N/A	N/A	7.14	.281
19140-0092	B-127-08T	14-16	2.00-1.30	N/A	N/A	7.14	.281
19140-0094	B-127-10T	14-16	2.00-1.30	N/A	N/A	7.14	.281
19140-0110	B-184-10T	14-16	2.00-1.30	N/A	N/A	7.14	.281
19140-0111	B-187-06T	14-16	2.00-1.30	N/A	N/A	7.14	.281
19140-0129	B-107-04T	14-16	2.00-1.30	N/A	N/A	7.14	.281
19140-0130	B-107-06T	14-16	2.00-1.30	N/A	N/A	7.14	.281
19140-0131	B-107-08T	14-16	2.00-1.30	N/A	N/A	7.14	.281
19140-0132	B-124-04T	14-16	2.00-1.30	N/A	N/A	7.14	.281
19140-0133	B-124-06T	14-16	2.00-1.30	N/A	N/A	7.14	.281
19140-0134	B-124-08T	14-16	2.00-1.30	N/A	N/A	7.14	.281
19140-0135	B-127-06T	14-16	2.00-1.30	N/A	N/A	7.14	.281
19140-0139	B-181-06T	14-16	2.00-1.30	N/A	N/A	7.14	.281
19140-0140	B-181-08T	14-16	2.00-1.30	N/A	N/A	7.14	.281
19140-0141	B-181-10T	14-16	2.00-1.30	N/A	N/A	7.14	.281
19140-0142	B-184-06T	14-16	2.00-1.30	N/A	N/A	7.14	.281
19140-0143	B-184-08T	14-16	2.00-1.30	N/A	N/A	7.14	.281
19140-0144	B-187-04T	14-16	2.00-1.30	N/A	N/A	7.14	.281
19140-0145	B-187-08T	14-16	2.00-1.30	N/A	N/A	7.14	.281
19146-0020	B-324-06T	14-16	2.00-1.30	N/A	N/A	7.14	.281
19146-0065	B-307-04T	14-16	2.00-1.30	N/A	N/A	7.14	.281
19146-0066	B-307-06T	14-16	2.00-1.30	N/A	N/A	7.14	.281
19146-0067	B-307-08T	14-16	2.00-1.30	N/A	N/A	7.14	.281
19146-0068	B-324-04T	14-16	2.00-1.30	N/A	N/A	7.14	.281
19146-0069	B-324-08T	14-16	2.00-1.30	N/A	N/A	7.14	.281
19170-0008	B-119-06T	14-16	2.00-1.30	N/A	N/A	7.14	.281
19170-0010	B-119-08T	14-16	2.00-1.30	N/A	N/A	7.14	.281
19170-0013	B-119-10T	14-16	2.00-1.30	N/A	N/A	7.14	.281
19172-0008	B-319-06T	14-16	2.00-1.30	N/A	N/A	7.14	.281
19172-0010	B-319-08T	14-16	2.00-1.30	N/A	N/A	7.14	.281

Air Feed Mylar Tape Applicator

Terminal No.	Terminal Eng. No.	Wire Size		Insulation Diameter Max.		Strip Length	
		AWG	mm <sup>2</sup>	mm	In.	mm	In.
19172-0012	B-319-10T	14-16	2.00-1.30	N/A	N/A	7.14	.281
19189-0010	B-131T	14-16	2.00-1.30	N/A	N/A	7.14	.281
19022-0026	MCT-1T	14-16	2.00-1.30	N/A	N/A	7.14	.281
19056-0103	B-337-04T	14-16	2.00-1.30	N/A	N/A	7.14	.281
19056-0105	B-337-06T	14-16	2.00-1.30	N/A	N/A	7.14	.281
19056-0108	B-337-08T	14-16	2.00-1.30	N/A	N/A	7.14	.281
19056-0111	B-337-10T	14-16	2.00-1.30	N/A	N/A	7.14	.281
19056-0113	B-339-04T	14-16	2.00-1.30	N/A	N/A	7.14	.281
19056-0115	B-339-06T	14-16	2.00-1.30	N/A	N/A	7.14	.281
19056-0117	B-339-08T	14-16	2.00-1.30	N/A	N/A	7.14	.281
19056-0119	B-339-10T	14-16	2.00-1.30	N/A	N/A	7.14	.281
19088-0070	B-382-06T	14-16	2.00-1.30	N/A	N/A	7.14	.281
19088-0071	B-382-08T	14-16	2.00-1.30	N/A	N/A	7.14	.281
19088-0072	B-382-10T	14-16	2.00-1.30	N/A	N/A	7.14	.281
19088-0073	B-385-06T	14-16	2.00-1.30	N/A	N/A	7.14	.281
19088-0074	B-385-08T	14-16	2.00-1.30	N/A	N/A	7.14	.281
19088-0075	B-385-10T	14-16	2.00-1.30	N/A	N/A	7.14	.281
19088-0076	B-388-04T	14-16	2.00-1.30	N/A	N/A	7.14	.281
19088-0077	B-388-06T	14-16	2.00-1.30	N/A	N/A	7.14	.281
19088-0078	B-388-08T	14-16	2.00-1.30	N/A	N/A	7.14	.281
19088-0079	B-388-10T	14-16	2.00-1.30	N/A	N/A	7.14	.281
19123-0059	B-380-06T	14-16	2.00-1.30	N/A	N/A	7.14	.281
19123-0060	B-380-08T	14-16	2.00-1.30	N/A	N/A	7.14	.281
19123-0061	B-380-10T	14-16	2.00-1.30	N/A	N/A	7.14	.281
19123-0062	B-383-06T	14-16	2.00-1.30	N/A	N/A	7.14	.281
19123-0063	B-383-08T	14-16	2.00-1.30	N/A	N/A	7.14	.281

Terminal No.	Terminal Eng. No.	Wire Size		Insulation Diameter Max.		Strip Length	
		AWG	mm <sup>2</sup>	mm	In.	mm	In.
19123-0064	B-383-10T	14-16	2.00-1.30	N/A	N/A	7.14	.281
19123-0065	B-386-04T	14-16	2.00-1.30	N/A	N/A	7.14	.281
19123-0066	B-386-06T	14-16	2.00-1.30	N/A	N/A	7.14	.281
19123-0067	B-386-08T	14-16	2.00-1.30	N/A	N/A	7.14	.281
19146-0070	B-327-06T	14-16	2.00-1.30	N/A	N/A	7.14	.281
19146-0071	B-327-08T	14-16	2.00-1.30	N/A	N/A	7.14	.281
19146-0072	B-327-10T	14-16	2.00-1.30	N/A	N/A	7.14	.281
19146-0076	B-381-06T	14-16	2.00-1.30	N/A	N/A	7.14	.281
19146-0078	B-381-08T	14-16	2.00-1.30	N/A	N/A	7.14	.281
19146-0079	B-381-10T	14-16	2.00-1.30	N/A	N/A	7.14	.281
19146-0080	B-384-06T	14-16	2.00-1.30	N/A	N/A	7.14	.281
19146-0081	B-384-08T	14-16	2.00-1.30	N/A	N/A	7.14	.281
19146-0082	B-384-10T	14-16	2.00-1.30	N/A	N/A	7.14	.281
19146-0083	B-387-04T	14-16	2.00-1.30	N/A	N/A	7.14	.281
19146-0084	B-387-06T	14-16	2.00-1.30	N/A	N/A	7.14	.281
19146-0085	B-387-08T	14-16	2.00-1.30	N/A	N/A	7.14	.281
19189-0013	B-1131T	14-16	2.00-1.30	N/A	N/A	7.14	.281
19203-0043	B-S-123-06T	14-16	2.00-1.30	N/A	N/A	7.14	.281
19203-0045	B-S-125-14T	14-16	2.00-1.30	N/A	N/A	7.14	.281
19203-0046	B-S-125-56T	14-16	2.00-1.30	N/A	N/A	7.14	.281
19203-0048	B-S-137-06T	14-16	2.00-1.30	N/A	N/A	7.14	.281
19203-0050	B-S-137-08T	14-16	2.00-1.30	N/A	N/A	7.14	.281
19203-0052	B-S-137-10T	14-16	2.00-1.30	N/A	N/A	7.14	.281
19215-0017	BA-331T	14-16	2.00-1.30	N/A	N/A	7.14	.281
19215-0115	BS-331T	14-16	2.00-1.30	N/A	N/A	7.14	.281

## DEFINITION OF TERMS

The following illustrations are a generic terminal representation and not an exact image of any terminal listed in the scope.

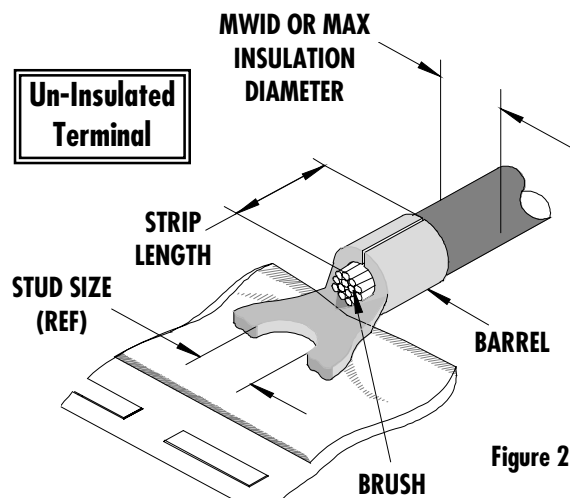
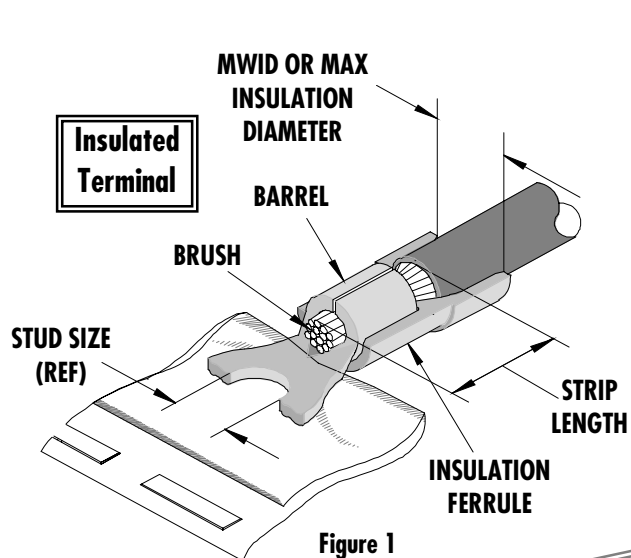

Figure 2

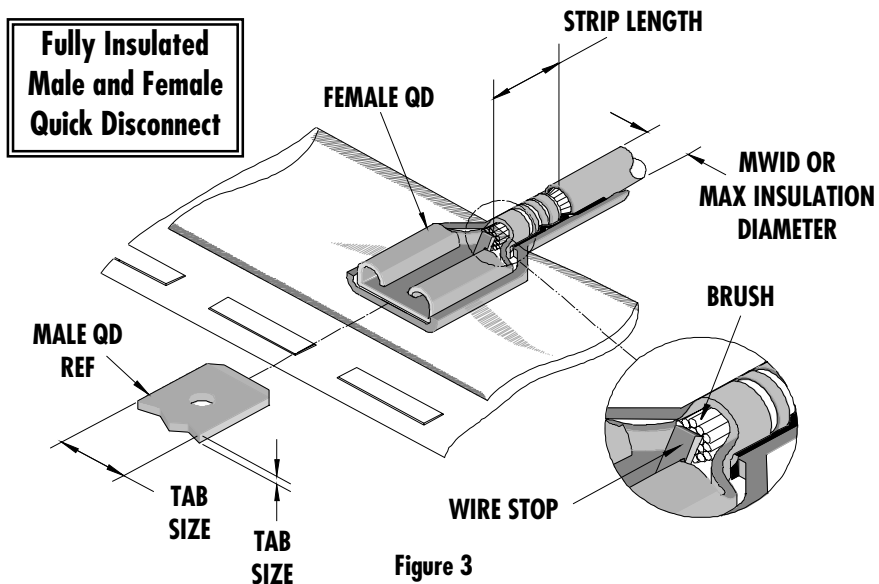
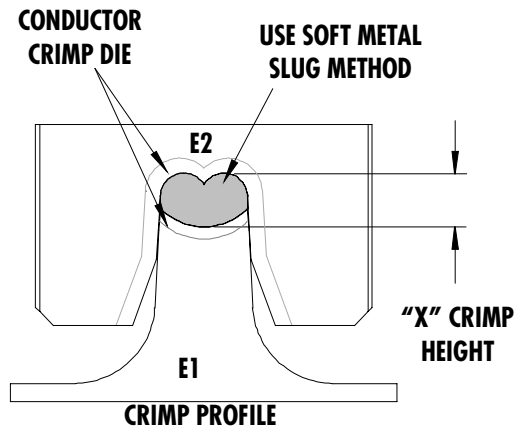

Figure 3

## Tool Calibration

To recalibrate this Applicator, make sure the power is completely shut off on the press.

1. The Mini-Mac applicator must be properly installed in the press.
2. Crimping dies must be properly installed in the Mini-Mac applicator.
3. The recommended method of measuring the crimp height of the conductor dies is the soft metal slug method, (See Figure 4).
4. The slug must have a diameter 0.51 mm (.020") larger than the "X" No Go dimension before crimping.
5. Place the soft metal slug (solder) into the nest of the bottom die and crimp (by hand cycling the press) similar to a terminal. The crimp height can be measured with a blade type micrometer or dial caliper, (Dimension "X").
6. Adjustment of the crimp height can be accomplished by indexing the conductor cam. The letter "A" gives the loosest position and "K" gives the tightest position. A total adjustment of 0.50mm (.020") can be achieved by adjusting the conductor cam.



Use soft metal slug (solder) method to measure the "X" dimension. Verify tooling crimp height calibration by referring to the Go/No Go dimensions shown in the chart below.

Figure 2

Note: If the crimp height is too tight on the setting "A", check the shut height of the press. See the Industrial Mini-Mac Applicator Manual Section 2.1 for adjustments.

## CRIMP SPECIFICATIONS

Wire Size		"X" Dimension Conductor Crimp						Pull Force Min.	
AWG	mm <sup>2</sup>	Mean		Go		No Go		Lbs	N
		In	mm	In	mm	In	mm		
16	1.30	.085	2.16	.082	2.08	.092	2.33	30.0	133.5
14	2.00	.085	2.16	.082	2.08	.092	2.33	50.0	222.6

Pull Force should be measured with no influence from the insulation crimp. The above specifications are guidelines to an optimum crimp.

**PARTS LIST**

<b>Mini-Mac Applicator 63885-8100</b>				
<b>Item</b>	<b>Order No</b>	<b>Engineering No.</b>	<b>Description</b>	<b>Quantity</b>
<b>Perishable Tooling</b>				
	63885-8170	63885-8170	Tool Kit (All "Y" Items)	REF
1	63465-0036	63465-0036	Conductor Punch	1 Y
2	63464-0037	63464-0037	Conductor Anvil	1 Y
<b>Other Components (Ref. 50050)</b>				
31	63466-0912	63466-0912	Anvil Mount	1
32	63466-0913	63466-0913	Terminal Support	1
33	63443-0021	63443-0021	Lower Tooling Key	1
42	63466-0921	63466-0921	Terminal Stripping Blade	1
51	63600-1290	63600-1290	Washer	1
52	63890-0866	63890-0866	Collar-6.35 Lg.	1
53	63890-0867	63890-0867	Collar-7.7 Lg.	1
<b>Frame</b>				
81	63801-3301	63801-3301	Air Feed Applicator Frame Head	REF
82	63801-3281	63801-3281	Base	REF
83	63801-5850	63801-5850	Track Assembly	REF
84	63801-3390	63801-3390	Air Kit	REF
<b>Hardware</b>				
91	N/A	N/A	M3 by 12 Lg SHCS	1**
92	N/A	N/A	M4 by 10 Lg SHCS	2**
93	N/A	N/A	M4 by 16 Lg. SHCS	1**
94	N/A	N/A	M4 by 45 Lg. SHCS	1**
95	N/A	N/A	M8 by 30 Lg. BHCS	1**
96	N/A	N/A	3mm by 6 Lg. Roll Pin	1**
** Available from an industrial supply company such as MSC (1-800-645-7270).				

**Note:** Crimp profiles used in 63885-8100 are equivalent to 19027-0055/ATP-B-120 (UL file number E32244).

# Assembly Drawing

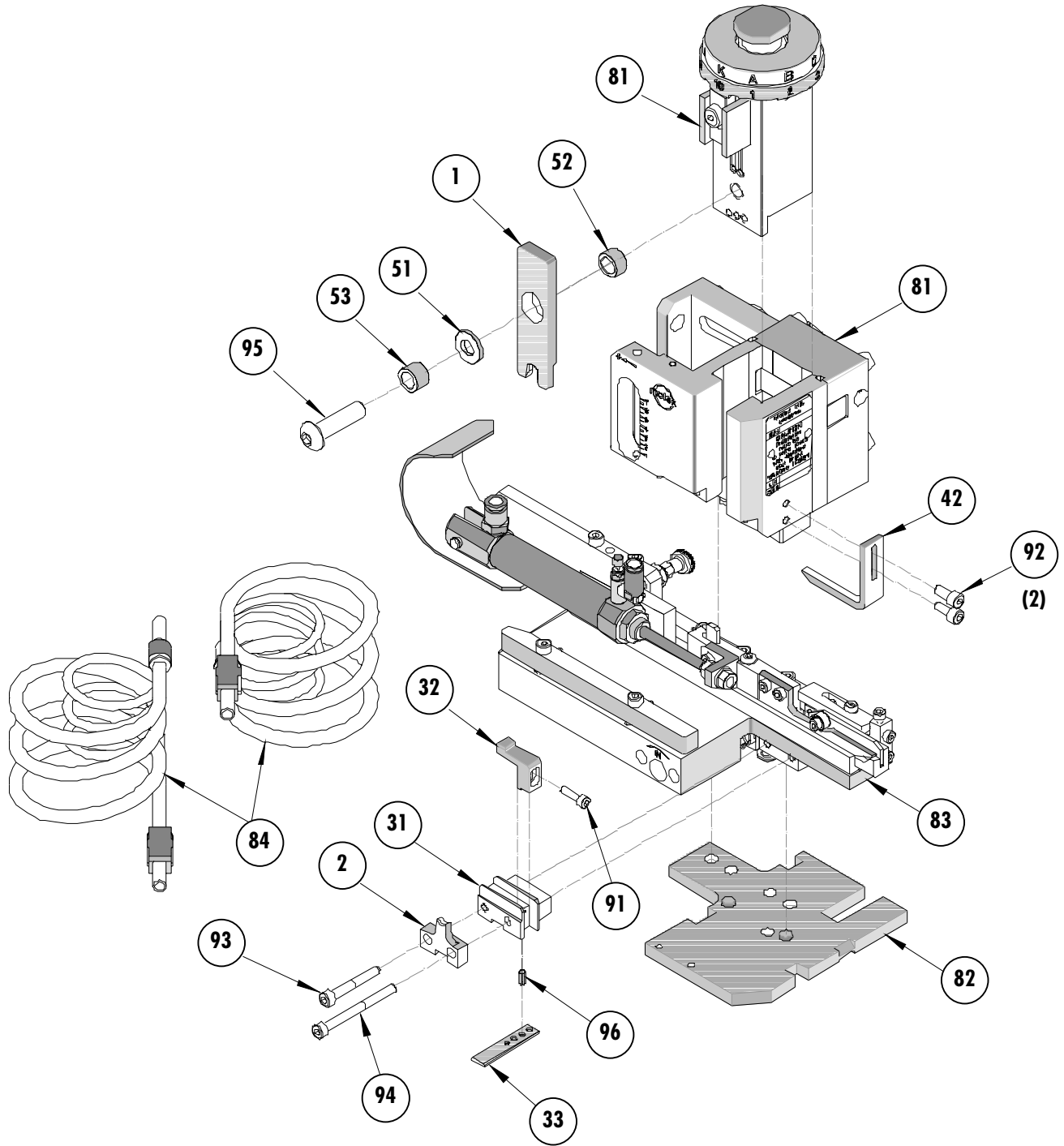

Figure 5

## NOTES

1. Molex recommends an extra perishable tooling kit be maintained at your facility.
2. Verify tooling alignment by manually cycling the press with applicator before crimping under power. Check that all screws are tight.
3. Slugs, terminals, dirt, and oil should be kept clear of work area.
4. Wear safety glasses at all times.
5. For recommended maintenance refer to the Mini-Mac Applicator Manual (Document no. 63880-0000).

**CAUTION:** This applicator should only be used in a press with a shut height of 135.80 mm (5.346"). Tooling damage could result at a lower setting.

**CAUTION:** To prevent injury, never operate this applicator without the guards supplied with the press or wire-processing machine in place. Reference the press or wire processing manufacturer's instruction manual.

**CAUTION:** Molex crimp specifications are valid only when used with Molex terminals, applicators and tooling.

## Contact Information

For more information on Molex application tooling please contact Molex at 1-800-786-6539.

### Molex Application Tooling Group

1150 E. Diehl Road  
Naperville, IL 60563  
Tel: (630) 969-4550  
Fax: (630) 505-0049

Visit our Web site at <http://www.molex.com>