

THIS COPY IS PROVIDED ON A RESTRICTED BASIS AND IS NOT TO BE USED IN ANY WAY DETRIMENTAL TO THE INTERESTS OF PANDUIT CORP.

NOTE:
1. MILLIMETER ARE IN [].

PART NUMBER	SEE DETAIL	MATERIAL	"A" +/- .062	"B" +/- .062	INSIDE NOMINAL DIA.	MARKER ACROSS	TUBING COLOR	PKG. QTY.	SEE STYLE
H200X084HFT-2	A	GMUHF	2.00 [50.8]	3.50 [88.9]	1/2 in. [12.7 mm]	1	WHITE	500	A
H200X084HGT-2	A		2.00 [50.8]				YELLOW		
H100X084HFT-2	B		1.00 [25.4]	2		WHITE	1000		
H100X084HGT-2	B		1.00 [25.4]			YELLOW			

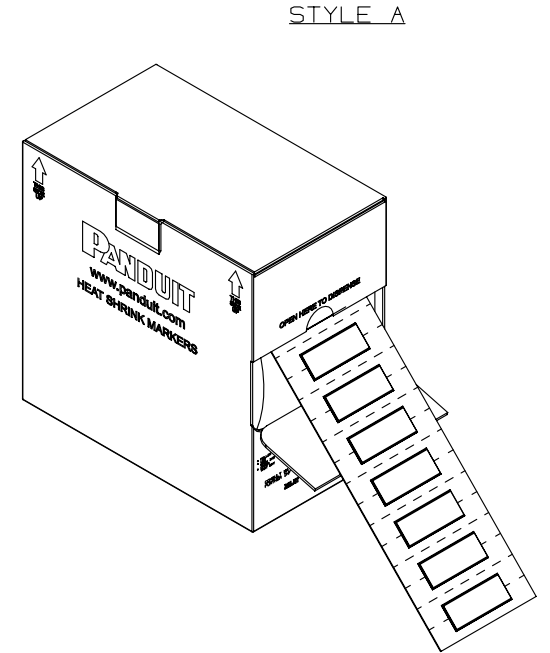
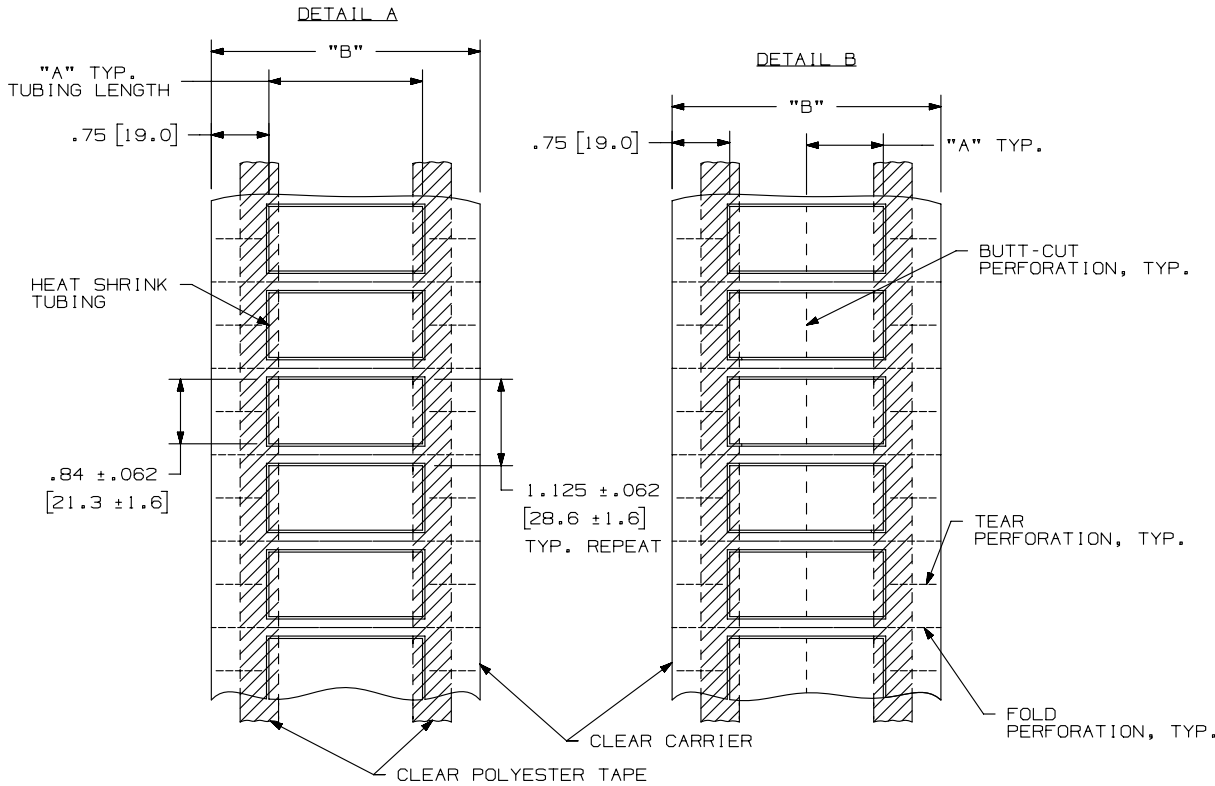

REV	DATE	BY	CHK	APR	DESCRIPTION	ECN
2	2/4/13	RVU	DAPE	SEWH	REMOVE 100X84HFT-2-B, H200X084HFT-2-B, 100X84HGT-2-B, AND H200X084HGT-2-B.	GAECN00576
1	8/23/11	RVU	DAPE		*Change marker height tolerance from .032" to .062" to match other HST drawings tolerances. Update on view. REMOVE STYLE B.	6481
0	6/2/11	RVU	DAPE		DRAWING RELEASE.	6412

TITLE		H***X084H*T-2 TWO-SIDED HEAT SHRINK LABEL, HALOGEN FREE CUSTOMER DRAWING	
ITEM REVISION NAME		100472XN/02	
DATASET FILE NAME		100472XN-DC-C10930/02C	
UNLESS OTHERWISE SPECIFIED, DIMENSIONAL TOLERANCES ARE: IN [mm]		PANDUIT TM MATERIAL: HEAT SHRINK TUBING, GMUHF	
.x ± .12 [3.05] .xxx ± .015 [.381] .xx ± .062 [1.57] ANGLES ±		DRAWING NUMBER: C10930	
DRAWN BY: RVU DATE: 6/2/11 CHK: MSAD SCALE: NTS		THIRD ANGLE PROJECTION SHT 1 OF 1 SIZE: A	

D101000DA/12