

| REV | DATE | APPR | DESCRIPTION              |
|-----|------|------|--------------------------|
| 16  | BD   | 39   |                          |
|     |      |      | REVISIONS                |
|     |      |      | ZONE LTR                 |
|     |      |      | A REDRAWN ON CAD         |
|     |      |      | B REVISED PER ECN BDS388 |
|     |      |      | DATE 5-18-80             |
|     |      |      | APPR                     |
|     |      |      | 11/29/78                 |
|     |      |      | FWL                      |

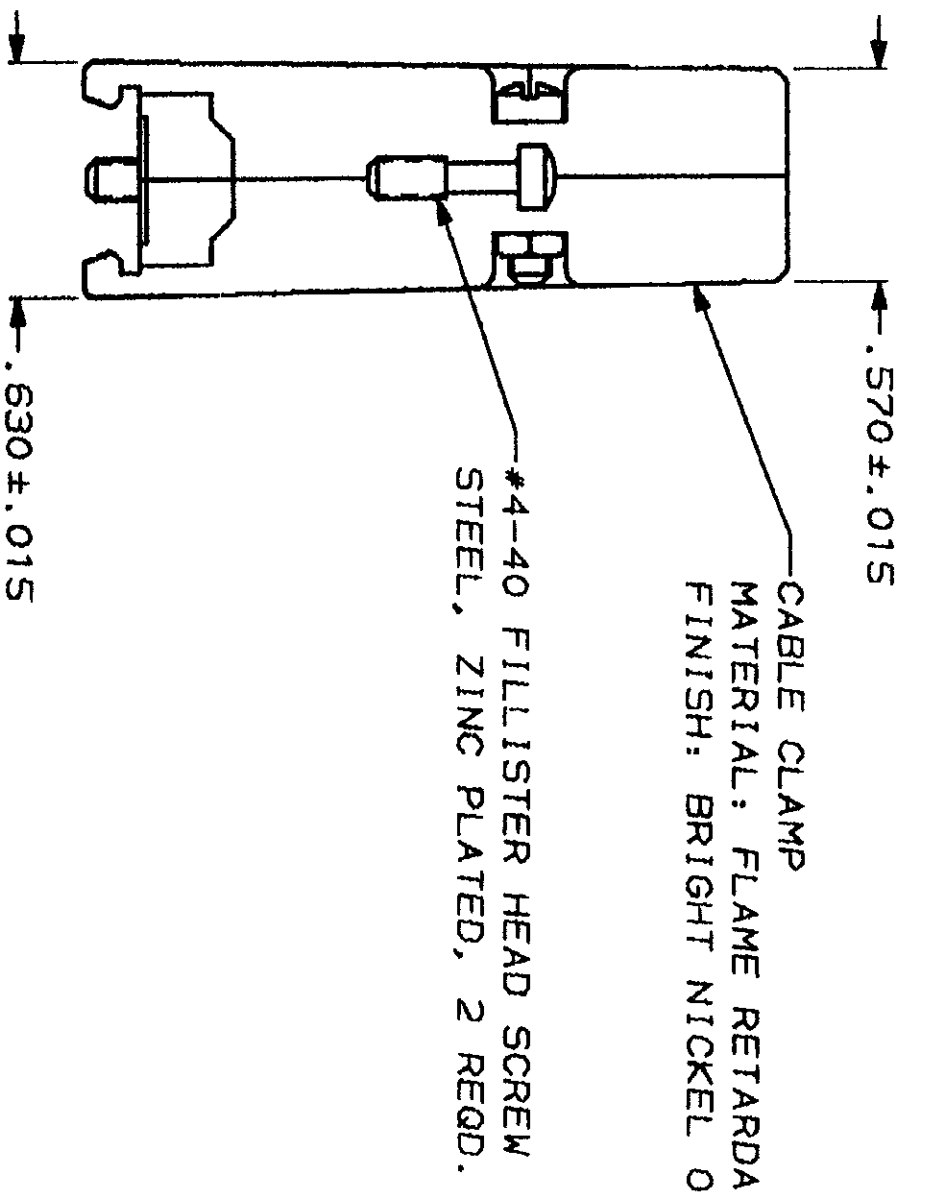
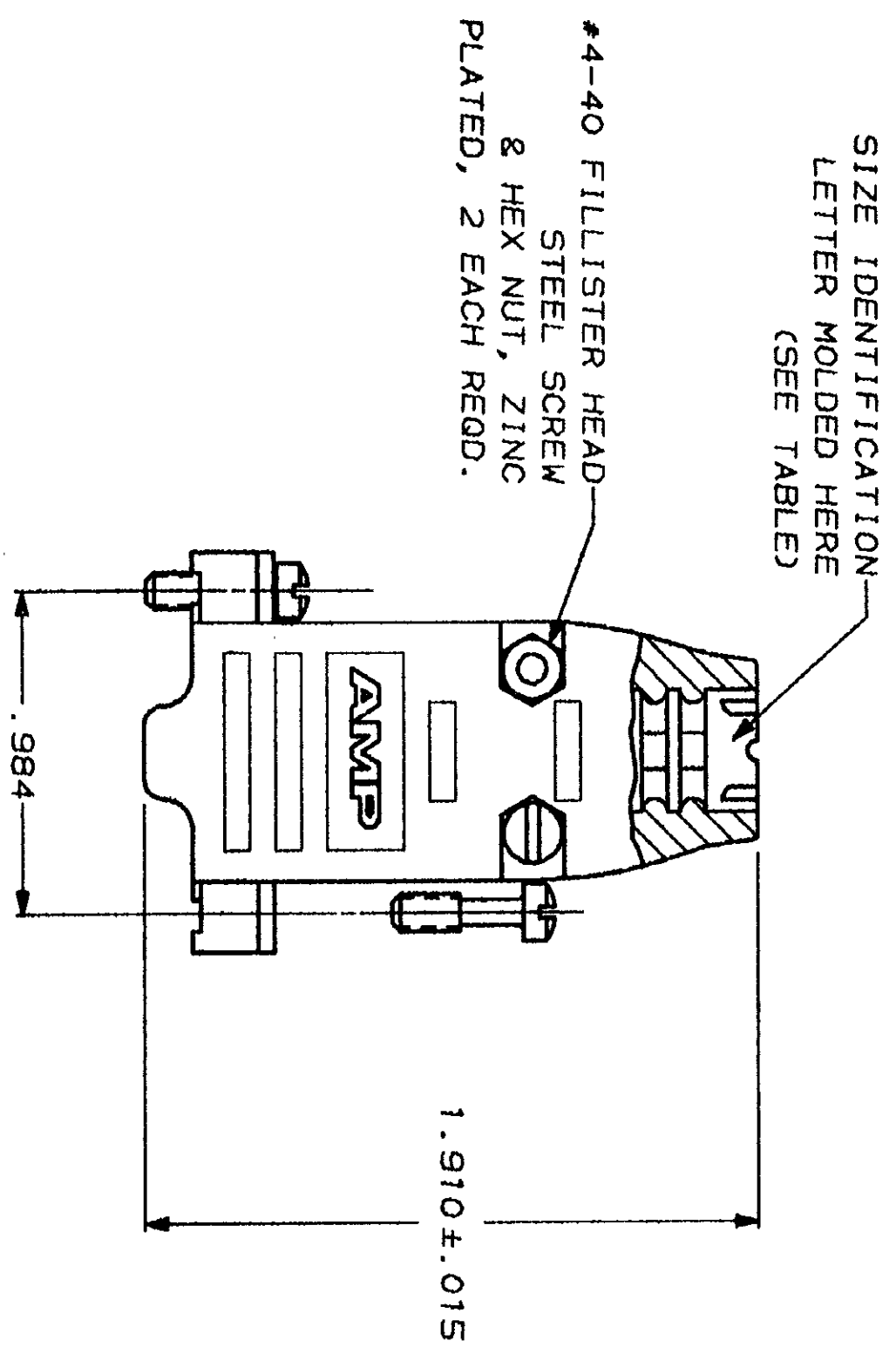
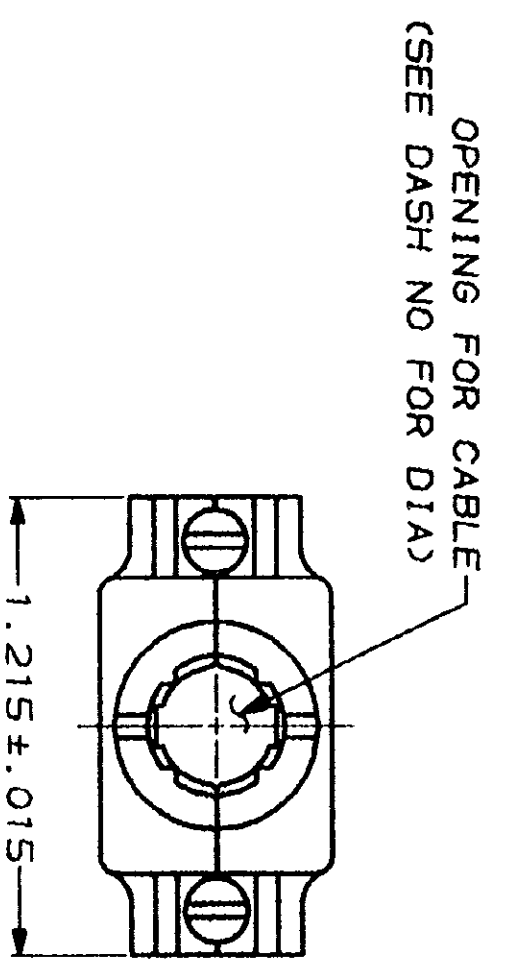

- 1 ALL PARTS PACKAGED UNASSEMBLED.
- 2 AS SHOWN ABOVE, THIS KIT CONSISTS OF 2 STRAIN RELIEF HALVES, 2 #4-40 SCREWS, 2 #4-40 NUTS & 2 #4-40 MOUNTING SCREWS.
- 3 SAME AS SHOWN, EXCEPT: EACH PART IS INDIVIDUALLY BULK PACKED FOR MULTIPLE KIT ORDERS.
- 4 OBSOLETE

| REMARKS | SIZE IDENT LETTER | CABLE DIA | BULK PACKED KIT NO | INDIVIDUAL KIT NO |
|---------|-------------------|-----------|--------------------|-------------------|
| 1       | A                 | .200      | 745854-6           | 745854-5          |
|         | C                 | .250      | 745854-4           | 745854-3          |
|         | H                 | .370      | 745854-2           | 745854-1          |

DO NOT SCALE PRINT.  
UNLESS SPECIFIED  
DIMENSIONS IN INCHES  
TOLERANCES ON:  
2 PLC DEC # .005  
3 PLC DEC # .005  
ANGLES #

DR 5-16-90  
CHK 9-10-90  
J. GALLOCCI BS  
J. McCLINTON

APPD 9-10-90  
J. WESTMAN

APPD 9-11-90  
J. ASSINI

PRODUCT SPEC

FINISH SEE CALLOUT

APPLICATION SPEC

WEIGHT

SCALE 2:1

AMP INCORPORATED  
Harrisburg, Pa. 17105

CABLE CLAMP KIT, SIZE 1, 9 POSN,  
180°, PLATED PLASTIC,  
AMPLIMITE™

745854

745854

1 OF 1