

REV	CHANGE	DATE	DRN	CHK
	Drawn	3	SJ	T

TOLERANCE DETAILS					
1	D	+0.010 [+0.25] -0.000 [-0.00]	6	PD	+0.000 [+0.00] -0.010 [-0.25]
2	L	±0.015 [±0.38]	7	PL	±0.015 [±0.38]
3	W	+0.005 [+0.13] -0.000 [-0.00]	8	SD	±0.005 [±0.13]
4	HD	+0.015 [+0.38] -0.000 [-0.00]	9	SL	±0.010 [±0.25]
5	HL	±0.010 [±0.25]	10	TL	+0.000 [+0.00] -0.015 [-0.38]

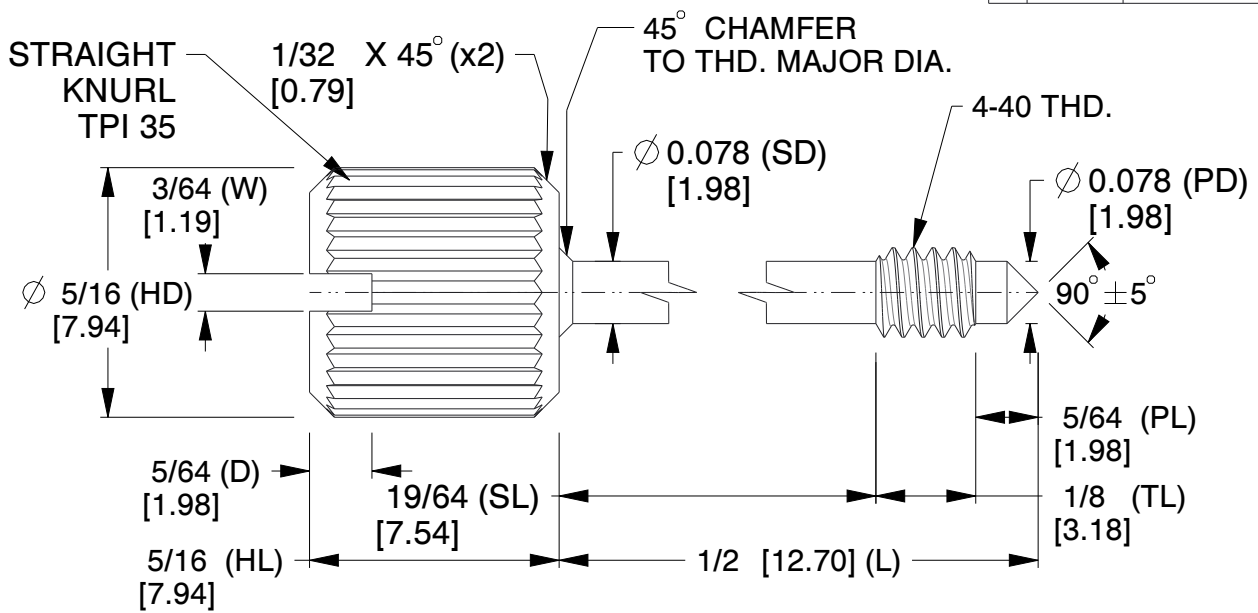

**NOTES:**

1. Material : Stainless Steel
2. Finish : No Plate
3. ASME Y14.5-M - 2009
4. All Drawing Dimensions are in Inches [mm]
5. Unless otherwise specified; Edge Breaks, Radii or Countersinks 0.005-0.015

COMPONENT	PANEL SCREW
0380-SS	SCALE
	4.16
	SHEET
	1 of 1



95 Silvermine Rd., Seymour CT 06483  
Tel: 203-888-2133, Fax: 203-888-9860

This Drawing is the Property of RAF. It contains confidential, proprietary information that is RAF property. Do not disclose to or duplicate for others except as authorized by RAF.

**TOLERANCES**  
ALL DIMENSIONS ARE INCHES (UNLESS OTHERWISE SPECIFIED)  
**METALLIC**  
LENGTHS < 6 INCHES ± 0.005  
LENGTH > 6 INCHES ± 0.010  
DIAMETERS: ± 0.005  
**NON-METALLIC**  
LENGTH: ± 0.010 DIAMETERS: ± 0.010  
**INTERNAL THREADS:**  
MINIMUM THREAD DEPTH