

SPEAKER-1318-4.5-SC-DUMBO

The 13x18x4.5 mm rectangular Dumbo speaker is a high end miniature speaker specifically designed for portable consumer devices, such as music phones, smartphones or tablet computers where high quality sound is required. It is the world's first miniature speaker featuring Knowles' advanced membrane technologies resulting in a state-of-the-art silicone membrane. This unique Knowles silicone membrane enables ultra-high excursion rates providing extended low frequencies (650 Hz in 1cm³ backvolume) and superior bass performance. The Dumbo speaker also features a higher power handling capacity up to 700 mW and is compliant according to the IPX7 waterproof standard.



Features:

- Optimized for extended low frequencies (f_0 : 650 Hz in 1cm³ backvolume)
- Unique Knowles silicone membrane providing ultra-high excursion for minimum THD, Q-factor and tumbling
- Increased Power Handling Capacity (700 mW)
- IPX7 waterproof standard compliant
- 100% in-line measurement of all specified acoustical and electrical parameters

Contents

1. Theory of operation.....	3
2. Mechanical Layout and Dimensions.....	4
2.1. Main Dimensions.....	4
2.2. PWB Layout	5
2.3. Spring Force.....	6
2.4. HNO3 Test area	7
2.5. Part marking/labeling.....	8
2.6. Forces on component.....	9
2.7. Material List.....	10
Electrical and Acoustical Specifications.....	11
2.8. Frequency response	11
2.9. Electro-Acoustic Parameters	12
2.10. Power handling.....	12
2.11. Measurement setup	13
2.12. Measured Parameters.....	13
2.13. Measurement adapter	14
3. Environmental Conditions.....	15
3.1. Storage.....	15
3.2. Transportation.....	15
3.3. Functionality.....	15
4. Environmental tests	16
4.1. Qualification tests.....	16
4.2. Reliability tests	16
4.3. Sample Size, Sequence	16
4.4. Period of Shelf-Life	16
4.5. Testing Procedures.....	16
5. Related Documents	20
6. Change History	21
7. Disclaimer	21

2403 260 00057

1. Theory of operation

The 13x18x4.5 mm rectangular Dumbo speaker is an electrodynamic transducer, designed to translate electrical analog signals into sound. The input signal is fed into a coil in a magnetic field, which is attached to a membrane. Through the principle of the electromagnetic force, the membrane is moved according to the contents of the input signal.

2403 260 00057

2. Mechanical Layout and Dimensions

2.1. Main Dimensions

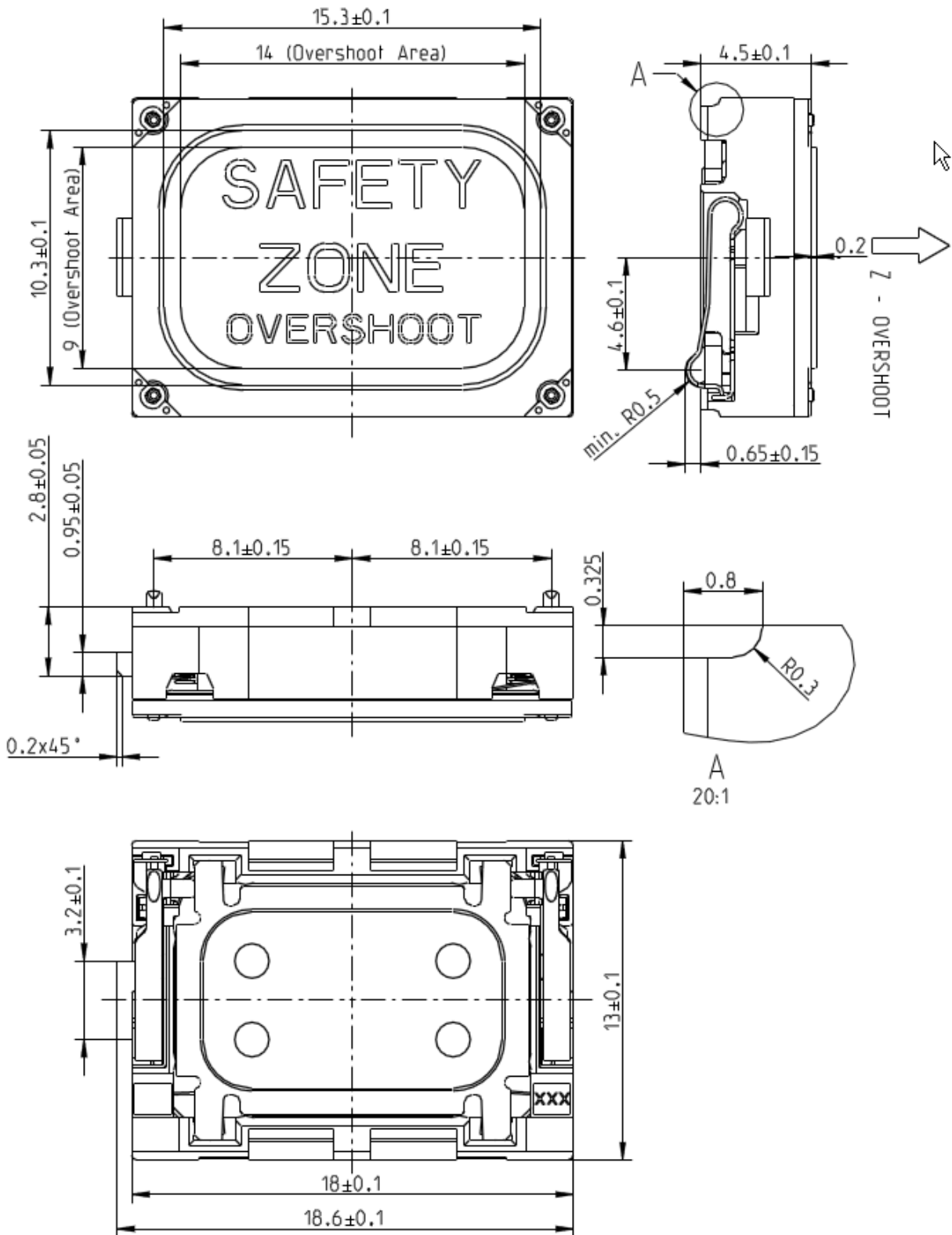

2403 260 00057

2.2. PWB Layout

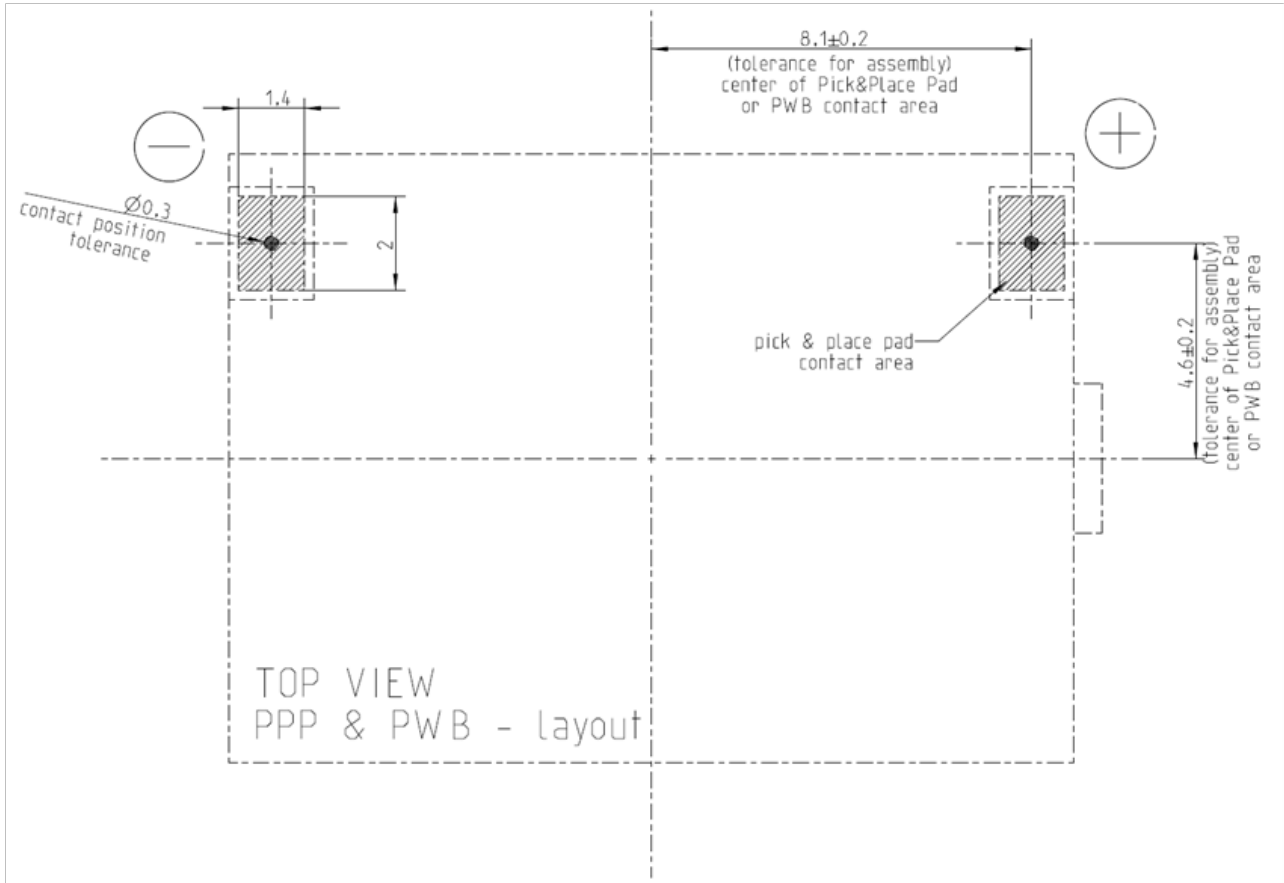

positive voltage on pin +
moves membrane in direction of arrow

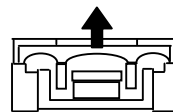

2.3. Spring Force

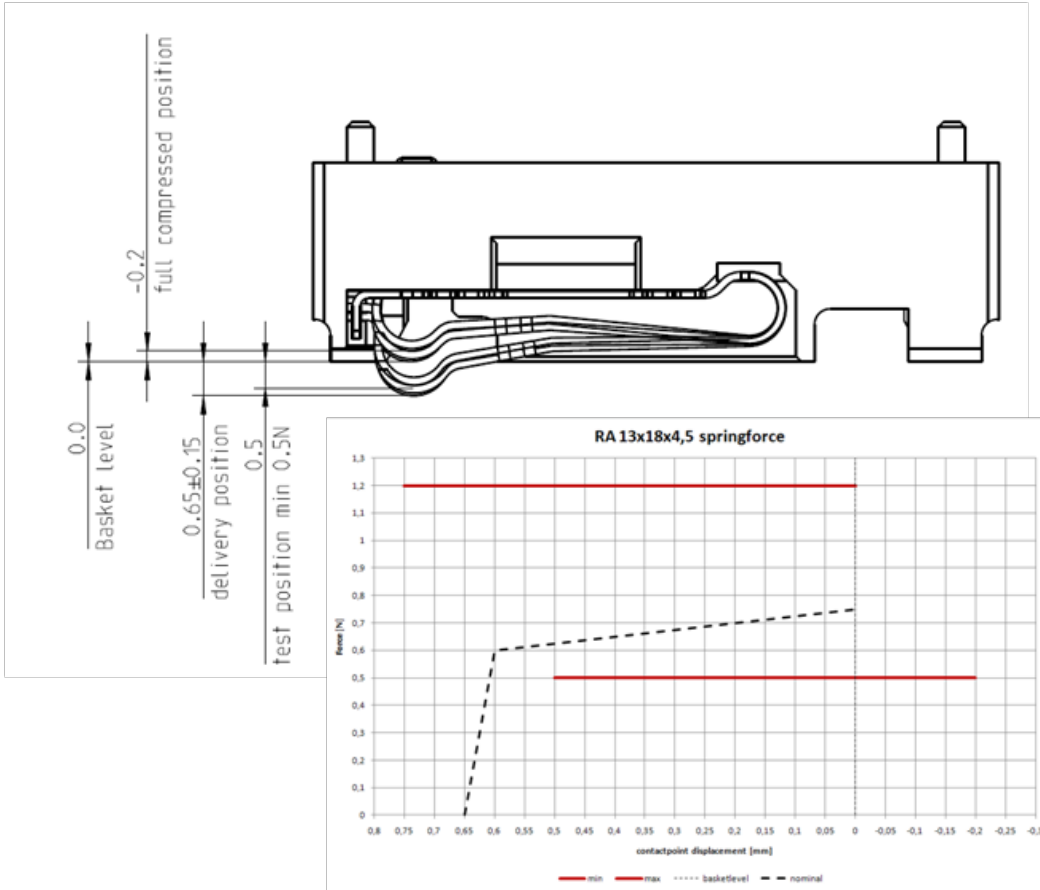

SPRING FORCE TABLE		
Force at Basket level	0 mm	max 1,2 N
Force at Start Workingposition	0,5 mm	min 0,5N
uncompressed (delivery position)	0 N	0,65 +/- 0,15mm
Force at PPP level	-0,2 mm	max 1,2 N

2.3.1. Test method:

- Test speed V=10mm/min
- Load contact spring 2x to basket level (0mm)
- The min. contact spring force shall be measured at test position (0,5mm) (second backwards stroke of diagram)
- Load contact spring to full compressed (-0,2mm) and measure max. contact spring force

2403 260 00057

2.4. HNO3 Test area

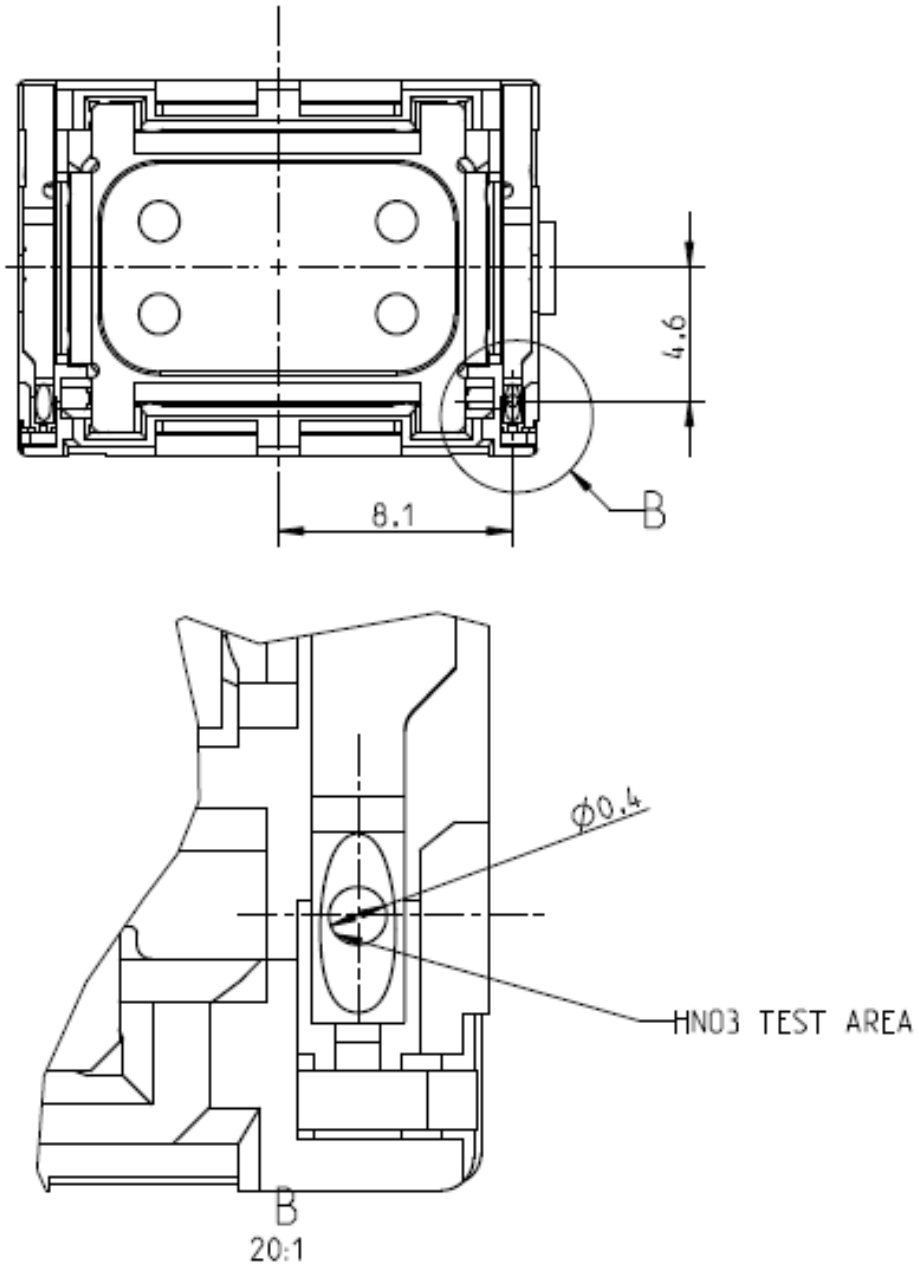

2403 260 00057

2.5. Part marking/labeling

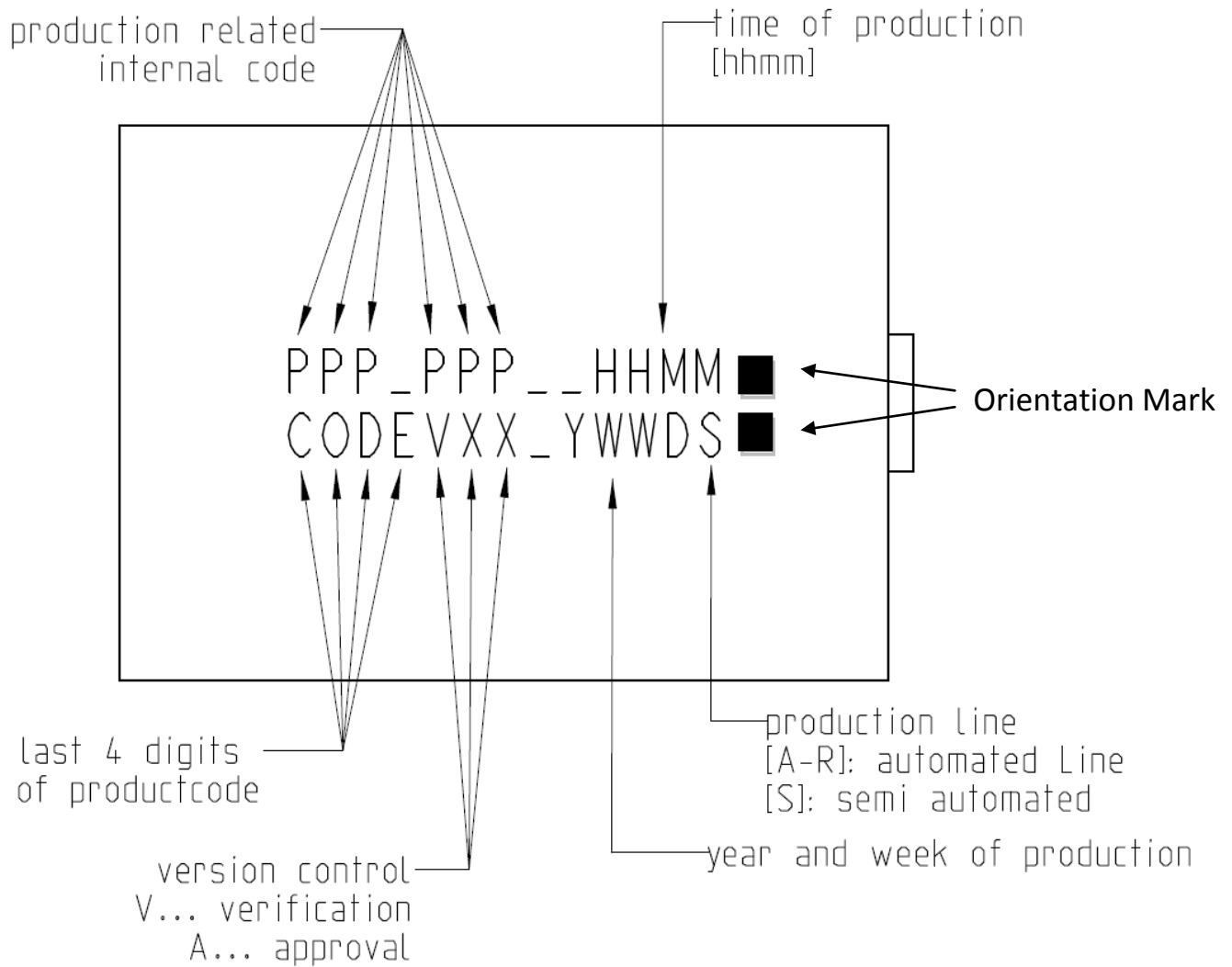

2403 260 00057

2.6. Forces on component

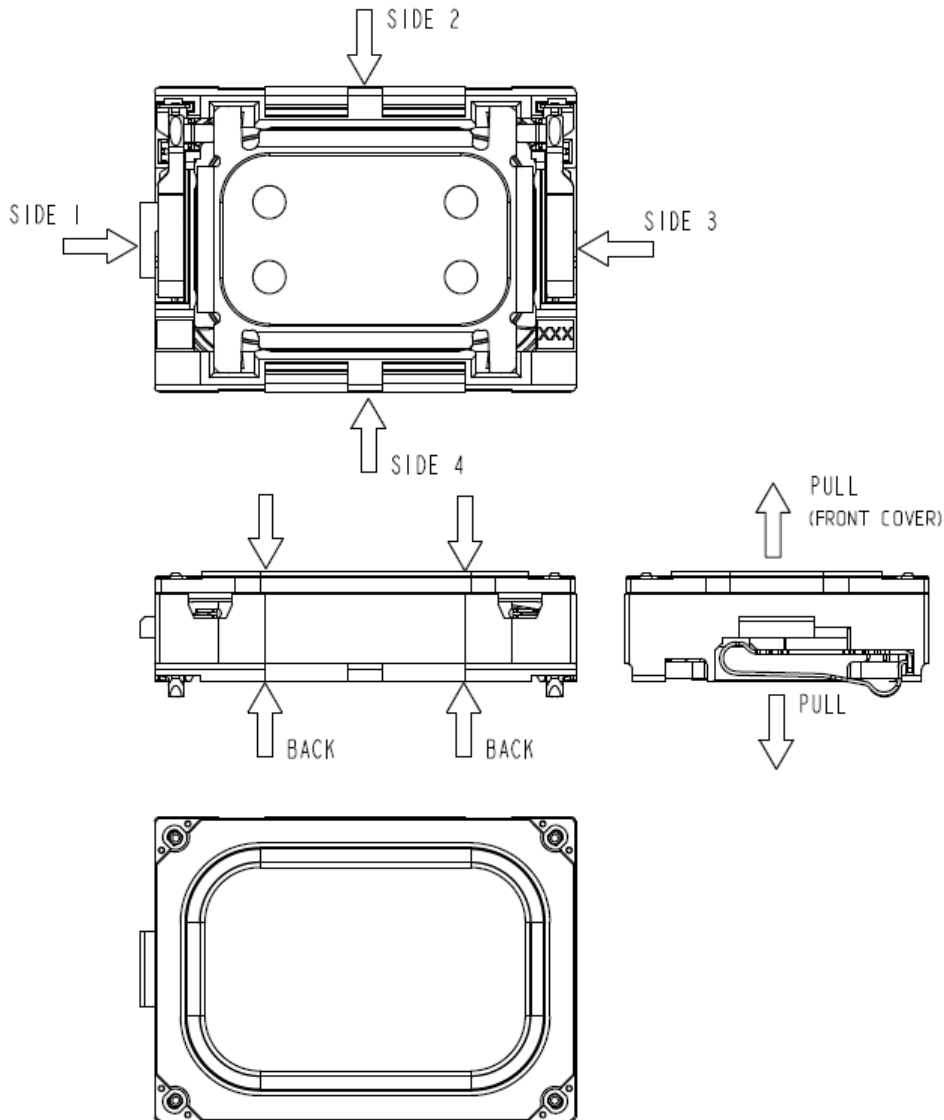

FORCES ON DIFFERENT STATE OF COMPONENT			
STATE	MIN.SURFACE OF PRESSURE [mm ²]	MAX. PERMANENT FORCE [N]	MAX. HANDLING FORCE [N]
FROM FRONT TO BACK	-	10	15
FROM SIDE 1 TO SIDE 3	3	10	15
FROM SIDE 2 TO SIDE 4	10	10	15
TO POT	-	0	3
TO MEMBRANE	-	0	0
PULL OF FORCE	-	0	5

2403 260 00057

2.7. Material List

- | | |
|--------------------------|-------------------------------|
| 1. Material of basket: | Polycarbonate bromide free |
| 2. Material of membrane: | Silicone |
| 3. Material of pot: | soft magnetic Iron |
| 4. Material of magnet: | Nd Fe B |
| 5. Material of contact | CrNi-Steel gold plated |
| 6. Material of cover: | Polybutylenterephthalat (PBT) |
| 7. Dimensions: | 18x13x4,5mm |
| 8. Mass: | 2,65g |

2403 260 00057

Electrical and Acoustical Specifications

2.8. Frequency response

2.8.1. Frequency response with 1ccm back cavity

Typical frequency response measured on baffle according to chapter 2.6
(distance d = 10cm, P = 700mW, with 1ccm back cavity)

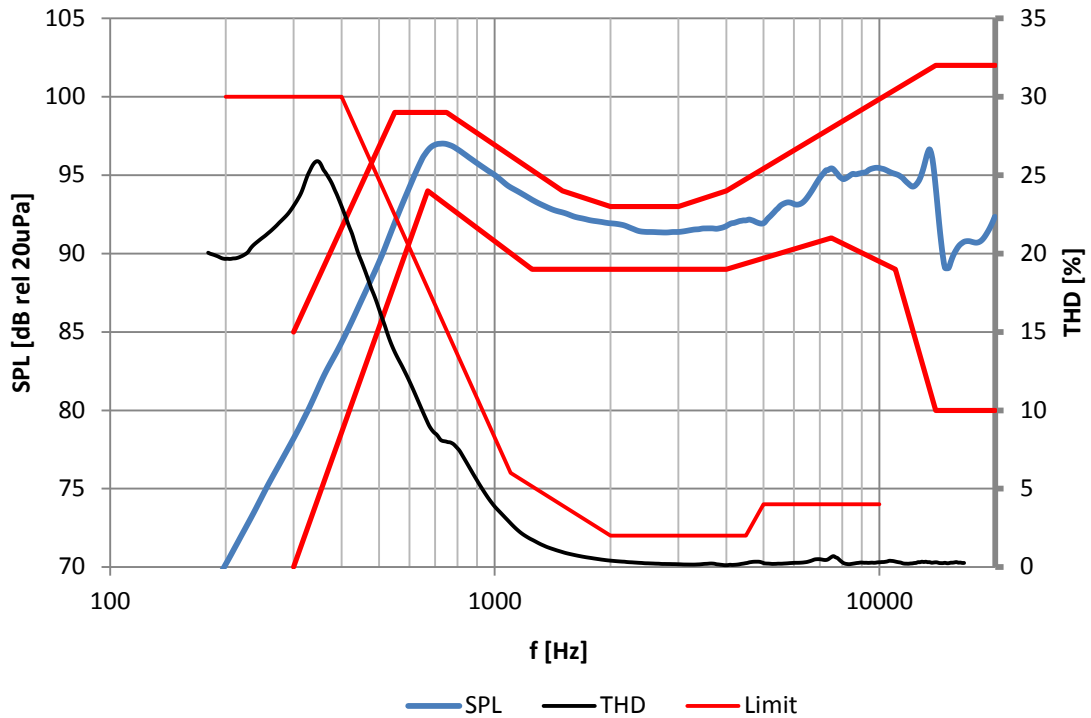

Tolerance window				
Frequency Response			THD	
f [Hz]	lower limit [dBSPL]	upper limit [dBSPL]	f [Hz]	upper limit [%]
300	70	85	200	30
550	-	99	400	30
670	94	-	1100	6
750	-	99	2000	2
1250	89	-	4500	2
1500	-	94	5000	4
2000	-	93	10000	4
3000	-	93		
4000	89	94		
7500	91	-		
11000	89	-		
14000	80	102		
20000	80	102		

2.9. Electro-Acoustic Parameters

Loudspeaker mounted in adapter acc. to 2.13.

1. Rated impedance	Z:	8Ω
2. Voice coil resistance	R:	7.2Ω±10%
3. Resonance frequency (measured @1ccm, 700mW)	f ₀ :	650Hz±7,5%
4. Maximum usable excursion x _{max}	p-p:	1 mm p-p
5. Nominal characteristic sensitivity (calculated for 1W in 1m) average from 2kHz to 4kHz		73±2dB
5.1. Measured characteristic sensitivity (at 700mW in 10cm) average from 2kHz to 4kHz		91,5±2dB
6. THD	according chapter 2.8.	
7. Rub & buzz (measured @ 10cm, 1ccm, 700mW (2.29V _{eff}) < 65dB SPL (300Hz -1500Hz)		

All acoustic measurements at 23±2°C

2.10. Power handling

Loudspeaker mounted in lifetime test device (1ccm back cavity, open front)

1. Max short term power (IEC268-1, 2 nd order high pass filtered, -3dB at 900Hz, crest factor 2)	(1sec. ON / 60sec. OFF)	1000mW (RMS)
2. Max continuous power (IEC268-1, 2 nd order high pass filtered, -3dB at 650Hz, crest factor 2)	(500h)	700mW (RMS)

2.11. Measurement setup

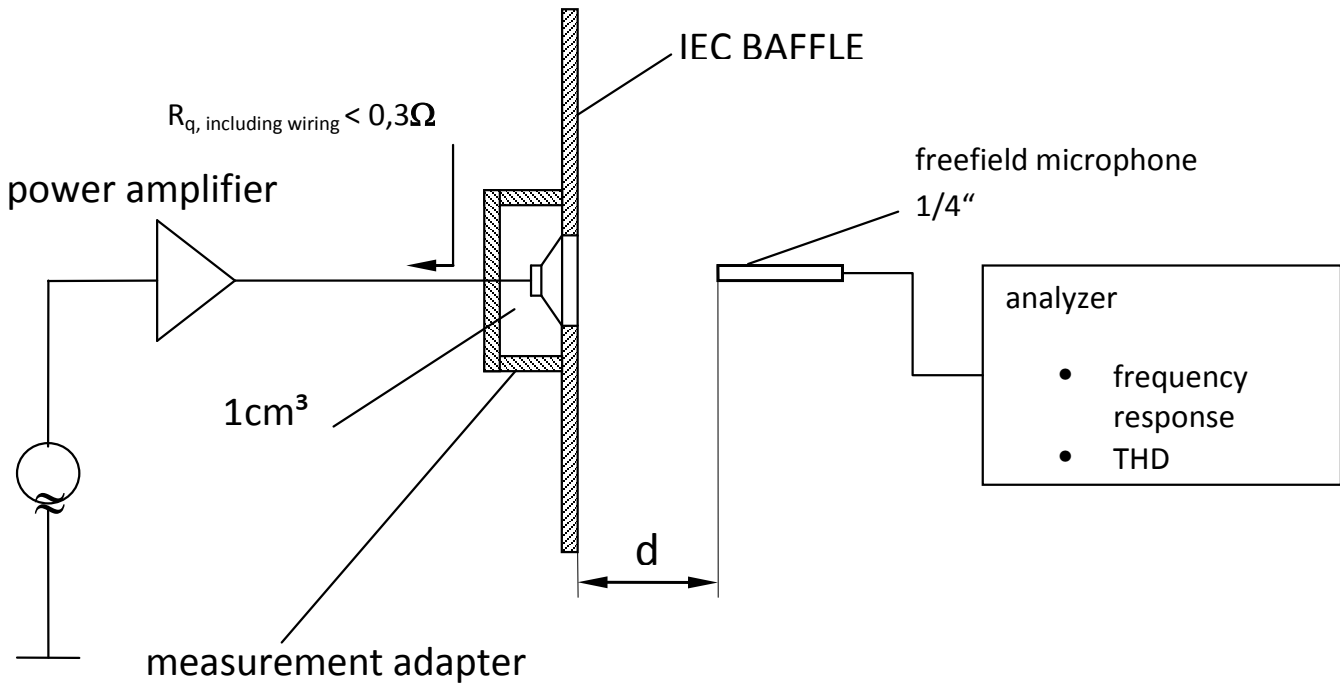

2.12. Measured Parameters

2.12.1. Sensitivity

SPL is expressed in dB rel $20\mu\text{Pa}$, computed according to IEC 268-5. Measurement set up and parameters according chapter 2.11. This test is performed for 100% of products in the production line.

2.12.2. Frequency response

Frequency response is measured according test set up in chapter 2.11 data sheet and checked against the tolerance window defined in chapter 2.8. This Test is performed for 100% of products in the production line.

2.12.3. Total harmonic distortion (THD)

Is measured according IEC 268-5 (2nd to 5th harmonics) and test set up in chapter 2.11. This test is performed for 100% of products in the production line.

2.12.4. Rub& Buzz

Rub & Buzz will be measured in the Inline-measuring device with a sinusoidal sweep. Rub and Buzz is defined as the maximum peak sound pressure in transmission range of the 5kHz high pass filter. Signal and evaluation criteria are according to chapter 2.9. This test is performed for 100% of products in the production line.

2403 260 00057

2.13. Measurement adapter

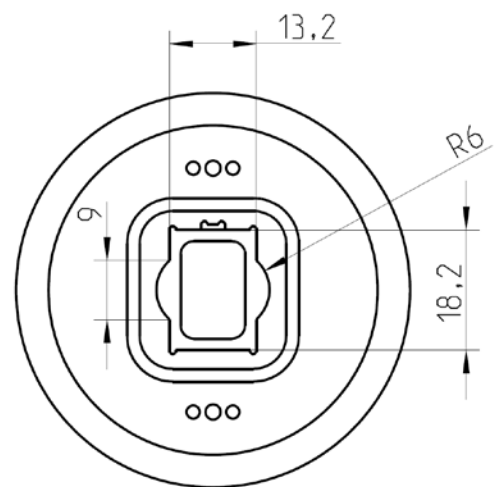
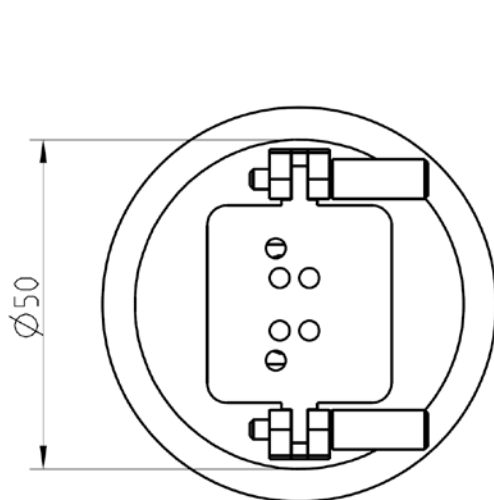
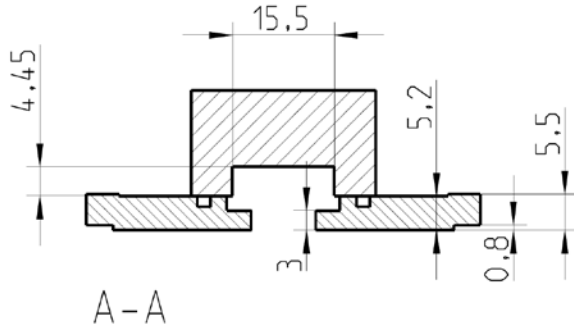
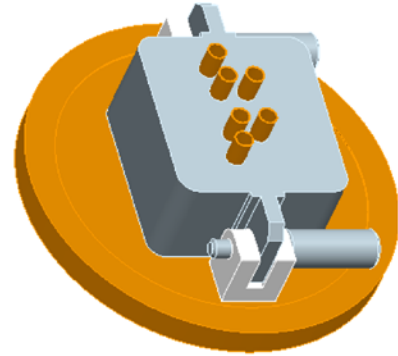
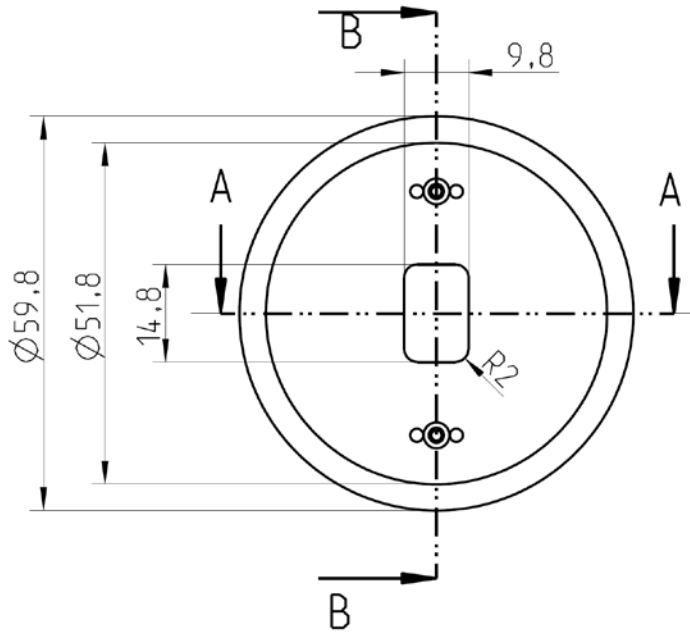

2403 260 00057

3. Environmental Conditions

3.1. Storage

The transducer fulfils the specified data after treatment according to the conditions of

ETS 300 019-2-1 Specification of environmental test: Storage
Test spec. T 1.2: Weather protected, not temperature controlled storage locations.

3.2. Transportation

The transducer fulfils the specified data after treatment according to the conditions of

ETS 300 019-2-2 Specification of environmental test: Transportation
Test Spec. T 2.3: Public Transportation

3.3. Functionality

The transducer fulfils the specified data after treatment according to the conditions of

ETS 300 019-2-5 Specification of environmental test: Ground vehicle installations
Test spec. T 5.1: Protected installation

ETS 300 019-2-7 Specification of environmental test: Portable and non-stationary use
Test spec. T 7.3E: Partly weather protected and non-weather protected locations.

4. Environmental tests

4.1. Qualification tests

According to our milestone plan (Product Creation Process), a complete qualification test will be done at design validation of products manufactured under serial conditions.

1x per year and product family a requalification takes place. The qualification process covers all tests described under 4.5 and a complete inspection.

4.2. Reliability tests

1x per month and product family samples are taken and submitted to tests described under 4.5.2

4.3. Sample Size, Sequence

Unless otherwise stated 20 arbitrary new samples will be used to perform each test for both, qualification and requalification test as described under 4.1 and 4.2.

4.4. Period of Shelf-Life

The period of shelf-life is 2 years.

4.5. Testing Procedures

4.5.1. Storage Tests

4.5.1.1. Low Temperature Storage Test

Parameter	Test Method and Conditions	Duration	Evaluation Standard
Low Temperature Storage (Ref. EN 60068-2-1)	-40°C rel. humidity not controlled	168h	Measurements after 2 hours recovery time. All samples fully operable. All acoustical parameters according specification with tolerances increased by 50 %.

4.5.1.2. High Temperature Storage Test

Parameter	Test Method and Conditions	Duration	Evaluation Standard
Dry Heat Storage (Ref. EN 60068-2-2)	+85°C rel. humidity not controlled	168h	Measurements after 2 hours recovery time. All samples fully operable. All acoustical parameters according specification with tolerances increased by 50 %.

2403 260 00057

4.5.1.3. Temperature Cycle Test

Parameter	Test Method and Conditions	Duration	Evaluation Standard
Change of Temperature (Ref. EN 60068-2-14)	-40°C/+85°C Transition time <3 min. See Figure 4-1 below	5 cycles >2h for each temperature	Measurements after 2 hours recovery time. All samples fully operable. All acoustical parameters according specification with tolerances increased by 50 %.

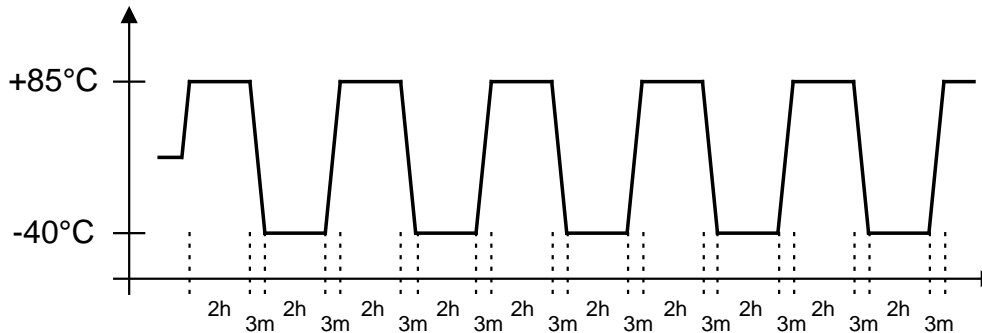

Figure 4-1: Temperature Cycle Test

4.5.1.4. Temperature / Humidity Cycle Test

Parameter	Test Method and Conditions	Duration	Evaluation Standard
Damp heat, cyclic (Ref. IEC 60068-2-30)	+25°C/+55°C 90% to 95% RH. Temp. change time <3h See Figure 4-2 below <u>Caution:</u> no condensed water on products!	6 cycles. 24h at each temperature	Measurements after 2 hours recovery time. All samples fully operable. All acoustical parameters according specification with tolerances increased by 50 %.

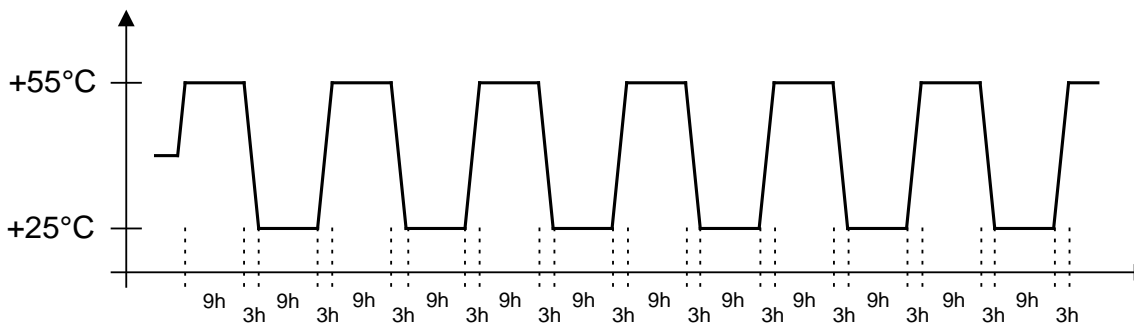

Figure 4-2: Temperature / Relative Humidity Cycle Test

4.5.2. Operating Tests

4.5.2.1. Cold Operation Test

Parameter	Test Method and Conditions	Duration	Evaluation Standard
Cold Operation Test (Ref. EN 60068-2-1)	-20°C rel. humidity not controlled signal acc. Chapter 2.10	72h	Measurements after 2 hours recovery time. All samples fully operable. THD may be increased after test. All other acoustical parameters according specification with tolerances increased by 50 %.

4.5.2.2. Dry Heat Operation Test

Parameter	Test Method and Conditions	Duration	Evaluation Standard
Dry Heat Operation (Ref. EN 60068-2-2)	+70°C rel. humidity not controlled signal acc. Chapter 2.10	500h	Measurements after 2 hours recovery time. All samples fully operable. The allowable change in sensitivity shall not be greater than 3 dB. All other acoustical parameters according specification with tolerances increased by 50 %.

4.5.3. Salt Mist Test

Parameter	Test Method and Conditions	Duration	Evaluation Standard
Salt Mist (Ref. IEC60068-2-52, Kb / Severity 2)	The part must be subjected to 2 hours spray of 5% NaCl salt mist, at 35°C then be left at 40°C and 95% RH for 22h.	3 cycles	The samples shall be washed after the test with distilled water and dried at T < 50°C. Component may have reduced performance, but must still function properly. The allowable sensitivity difference shall not be greater than ±3dB from initial sensitivity.

4.5.4. Shock Resistance Test (Free Fall Test) - unprotected product

Parameter	Test Method and Conditions	Conditions / Sample size	Evaluation Standard
Mechanical shock (Ref. IEC60068-2-32 Ed), Procedure 1	Drop of sample without fixation of release plane from a height of 1.5m onto concrete floor.	Each 3 shocks in both directions of the 3 axes. (18 drops in total)	Component may have reduced performance, but must still function properly. The allowable sensitivity difference shall not be greater than ±3dB from initial sensitivity.

2403 260 00057

4.5.5. Impact Durability Test (Tumble Test) – protected product

Parameter	Test Method and Conditions	Conditions / Sample size	Evaluation Standard
Impact durability (in a Tumble Tester) (Ref. IEC60068-2-32 Ed) (SPR a7.1.1)	Speaker <i>in drop test box</i> or representative mechanics. Random drops on steel base.	30 units 180 drops, 1m DUT power off	Component may have reduced performance, but must still function properly. The allowable sensitivity difference shall not be greater than ± 3 dB from initial sensitivity.

4.5.6. Resistance to Electrostatic Discharge

Parameter	Test Method and Conditions	Conditions / Sample size	Evaluation Standard
Resistance to ESD IEC61000-4-2 Level 4 (SPR c 2.5.1)	One pole is grounded and the ESD pulse is applied to the other pole. The speaker must be stressed first with one polarisation and then with the other polarisation. DUT must be discharged between each ESD exposure. Level 4: contact +/- 8kV, air +/- 15kV	10 exposures on each polarity / 5 units DUT Power off	All samples fully operable. All acoustical parameters according specification with tolerances increased by 50%.

4.5.7. Water-resistant

Parameter	Test Method and Conditions	Conditions / Sample size	Evaluation Standard
Water resistant acc. IPx7 (Ref. EN60529)	The part must be immersed in 1m of water for 30min in a appropriate test adapter.	10 units 1m, 30min	No ingress of water through the products allowed. Measurements after samples are dry. All samples fully operable. The allowable change in sensitivity shall not be greater than 3 dB. All other acoustical parameters according specification with tolerances increased by 50 %.

2403 260 00057

5. Related Documents

IEC 268-5	Sound System equipment Part 5: Loudspeaker
IEC 68-2	Environmental testing
EN 60068-2	Environmental testing
ISO 2859 - 1	Sampling procedures for inspection by attributes Part 1: Sampling plans indexed by acceptable quality level (AQL) for lot-by-lot inspection
ISO 3951	Sampling procedures and charts for inspection by variables for percent defectives.
ETS 300 019-2-1	Specification of environmental test: Storage Test spec. T 1.2: Weather protected, not temperature controlled storage locations
ETS 300 019-2-2	Specification of environmental test: Transportation Test spec. T 2.3: Public Transportation
ETS 300 019-2-5	Specification of environmental test: Ground vehicle installations Test spec. T 5.1: Protected installation
ETS 300 019-2-7	Specification of environmental test: Portable and non-stationary use Test spec. T 7.3E: Partly weather protected and non-weather protected locations

2403 260 00057

6. Change History

Status	Version	Date	ECR	Comment / Changes	Initials of owner
Obsolete	A	15.10.10	2957	First release	CP/FL/MW/EK
Obsolete	B	04.04.11	3108	New membrane technology	CP/SA/FH
Obsolete	C	16.08.11	3249	Add. Overshoot area in Product drawing (Page #4), modify measurement adapter (Page #14) Changed Chapter 3: From 1cm to 10cm Updated drawing of Measurement Adapter Updated Material List	FH/AH/SA/MS/CP
Release	D	28.10.11	3353	Modify feature description and theory of operation	AT/CP

7. Disclaimer

Stresses above the Absolute Maximum Ratings may cause permanent damage to the device. These are stress ratings only. The device may not function when operated at these or any other conditions beyond those indicated under “Electrical and Acoustical Specifications”. Exposure beyond those indicated under “Electrical and Acoustical Specifications” for extended periods may affect device reliability.

This product is not qualified for use in automotive applications

Frequency range in telecom application:
300 Hz – 3,4 kHz

The information contained in this literature is based on our experience to date and is believed to be reliable and it is subject to change without notice. It is intended as a guide for use by persons having technical skill at their own discretion and risk. We do not guarantee favorable results or assume any liability in connection with its use. Dimensions contained herein are for reference purposes only. For specific dimensional requirements consult factory. This publication is not to be taken as a license to operate under, or recommendation to infringe any existing patents. This supersedes and voids all previous literature.