

New W series of ultrafast rectifiers for welding applications



High-performance product series for low power consumption welders

In modern welding equipment, high-power secondary rectification causes around half of the power losses. This is mainly due to conduction in the diodes. ST has developed the new W series of ultrafast STTH rectifiers to overcome these losses, leveraging our long experience with market leaders in the welding industry.

Using platinum doping, the new W series of high-current diodes, from 20 A up to 200 A, are ideal for the latest requirements in welding equipment.

KEY FEATURES

- Lower V_F to reduce conduction losses
- Lower I_R
- Insulated packages available
- Green molding compound
- Ribbon bonding

KEY BENEFITS

- Efficient and cost-effective solution
- Improved robustness
- No need for redesign
- Environmentally friendly

MAIN APPLICATIONS

- Secondary rectification in
 - TIG (tungsten inert gas)
 - MIG (metal inert gas)
 - MMA (manual metal arc)
 - Plasma welding equipment
- PFC boost diodes and freewheeling diodes in primary stage



EXAMPLE WITH FULL-BRIDGE FORWARD CONVERTER TOPOLOGY

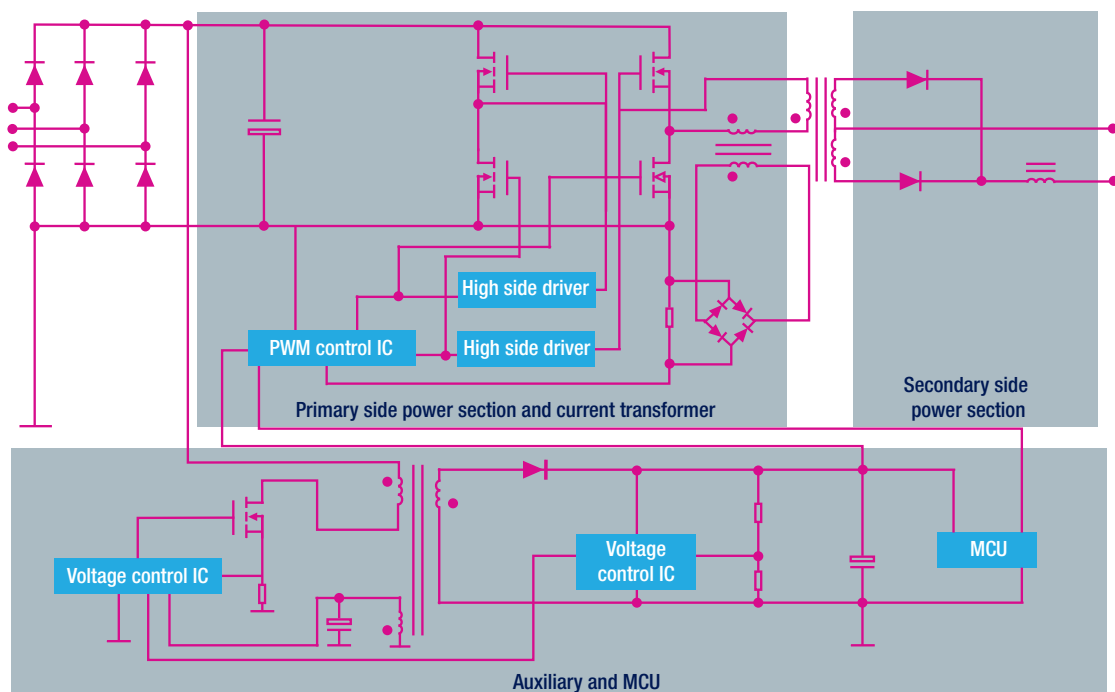

W ULTRAFAST SERIES PRODUCT TABLE

Part number	V_{RRM} (V)	$I_{F(AV)}$ (A)	Common cathode	T_j max (°C)	V_f typ @ 150 °C (V)	I_{RM} typ ^(*) (A)	Q_{RR} typ ^(*) (μC)	Package
200 V ultrafast diodes								
STTH20W02CW	200	20	Yes	175	0.89	7.0	0.15	TO-247
STTH30W02CW	200	30	Yes	175	0.90	7.0	0.16	TO-247
STTH60W02CW	200	60	Yes	175	0.85	8.0	0.22	TO-247
300 V ultrafast diodes								
STTH30W03CW	300	30	Yes	175	0.90	7.0	0.16	TO-247
STTH60W03CW	300	60	Yes	175	0.94	7.0	0.18	TO-247
STTH200W03TV1	300	200	No	150	0.95	9.0	0.40	ISOTOP
400 V ultrafast diodes								
STTH61W04SW	400	60	No	175	0.93	19.0	1.40	TO-247
STTH100W04CW	400	100	Yes	175	0.98	15.0	0.85	TO-247
STTH200W04TV1	400	200	No	150	1.05	17.0	0.90	ISOTOP
600 V ultrafast diodes								
STTH50W06SW	600	50	No	175	1.25	14.0	0.85	TO-247
STTH100W06CW	600	100	Yes	175	0.92	30.0	3.70	TO-247
STTH200W06TV1	600	200	No	150	1.00	30.0	4.60	ISOTOP

Notes:
^(*) Refer to the respective datasheets for the test conditions



© STMicroelectronics - October 2012 - Printed in United Kingdom - All rights reserved
 The STMicroelectronics corporate logo is a registered trademark of the STMicroelectronics group of companies
 All other names are the property of their respective owners

