

LI0805G201R-10

UNCONTROLLED DOCUMENT

PHYSICAL DIMENSIONS:

A	2.00 [.079]	+ 0.20 [.008]
B	1.25 [.049]	+ 0.20 [.008]
C	0.90 [.035]	+ 0.20 [.008]
D	0.51 [.020]	+ 0.25 [.010]

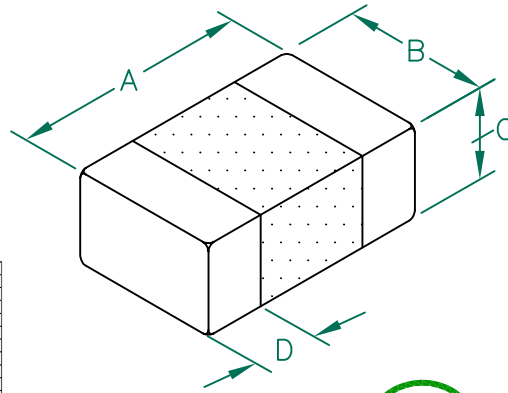

ELECTRICAL CHARACTERISTICS:

Z @ 100MHz (Ω)		DCR (Ω)	Rated Current
Nominal	200		
Minimum	150		
Maximum	250	0.3	700 mA

- NOTES: UNLESS OTHERWISE SPECIFIED
1. TAPED AND REELED per CURRENT EIA SPECIFICATIONS 7" REELS, 4000 PCS/REEL, PAPER TAPE.
 2. COMPONENTS SHOULD BE ADEQUATELY PREHEATED BEFORE SOLDERING.
 3. TERMINATION FINISH IS 100% TIN.
 4. OPERATING TEMP. RANGE: -40°C~+125°C. (INCLUDING SELF-HEATING)

Z vs FREQUENCY
IMPEDANCE UNDER DC BIAS

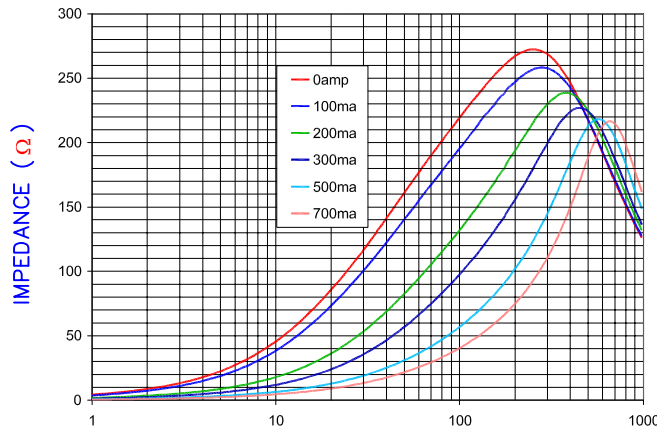

FREQUENCY (MHz)
|Z|, R, AND X vs. FREQUENCY

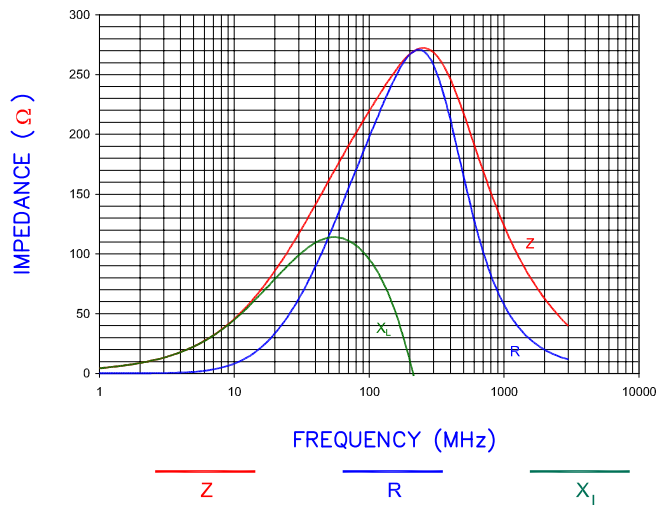

LAND PATTERNS FOR REFLOW SOLDERING

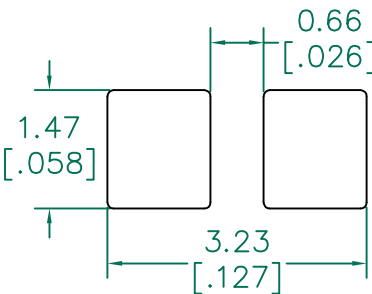

(For wave soldering, add 0.763 [.030] to this dimension.)

RECOMMENDED SOLDERING CONDITIONS

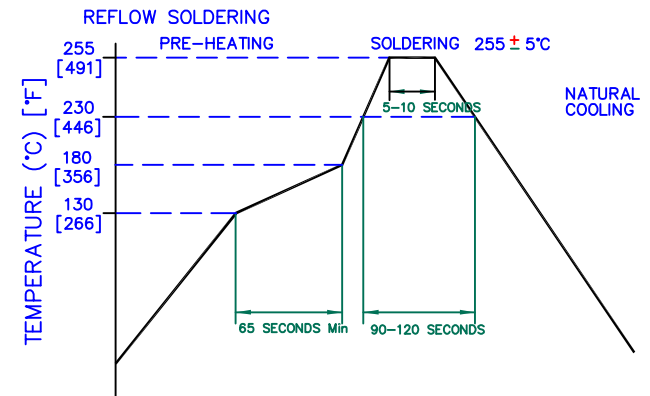

DIMENSIONS ARE IN mm [INCHES].

F	ADD OPERATING TEMPERATURE UPDATE LAIRD LOGO AND REFLOW CURVE	08/05/13	QU	This print is the property of Laird Tech. and is loaned in confidence subject to return upon request and with the understanding that no copies shall be made without the written consent of Laird Tech. All rights to design or invention are reserved.		
E	CHANGE TO PAPER TAPE	03/03/10	JUN	PROJECT/PART NUMBER: LI0805G201R-10		
D	UPDATE COMPANY LOGO	06/16/09	JRK	REV	F	PART TYPE: CO-FIRE
C	ADD ROHS SYMBOL MODIFY NOTE 1	11/28/06	JRK	DATE:	04/19/04	SCALE: NTS
B	CORRECT TEST REF #	01/03/06	JRK	GAD #	LI0805G201R-10-F	SHEET: 2 of 2
A	ORIGINAL DRAFT	04/19/04	JRK	TOOL #	-	
REV	DESCRIPTION	DATE	INT			

